

FLA COE  
 FLB COE  
 FLD Conventional  
 Business Class  
 FLC 112 Conventional

Century Class Conventional  
 Argosy COE  
 Cargo  
 Columbia  
 > 122SD and Coronado

Business Class M2  
 > Cascadia  
 108SD/114SD  
 New Cascadia

**Description of Revisions:** *This bulletin replaces the version dated 9/15/2017. **Figure 1** is revised to provide clarification about earlier vehicle behavior.*

## General Information

When there is a low air pressure condition on vehicles with an ICU4Me, the message center displays an alert indicating "Brake Air Supply Pressure Low" and a buzzer sounds, in compliance with FMVSS 121 and FMVSS 101. See **Fig. 1**, ref. C.

This *replaces* the previous low air pressure warning sequence, where a buzzer sounds and the low air pressure telltale illuminates.

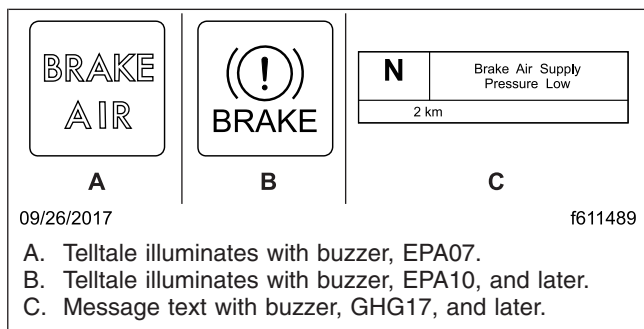

**Fig. 1, Low Air Pressure Warning Sequence Change**

## Warranty

This is an informational bulletin only. Warranty does not apply.