

Maintenance for HV & Auxiliary Batteries

Service Category General

Section Maintenance

Market USA

Lexus Supports
ASE Certification 

Applicability

YEAR(S)	MODEL(S)	ADDITIONAL INFORMATION
2018	ES300H, GS450H, LC500H, LS500H, NX300H, RX450H	

Introduction

Hybrid vehicles are equipped with 2 types of batteries:

- Hybrid Vehicle (HV) battery
- 12-volt auxiliary battery

If the vehicle is put into storage, the State-Of-Charge (SOC) of its HV battery and auxiliary battery will gradually decrease. To prevent the auxiliary battery from becoming discharged during storage, proper maintenance is necessary.

Perform the following maintenance service for the HV battery and 12-volt auxiliary battery.

NOTE

- Before disconnecting the auxiliary battery, confirm the shift lever is in the "P" position and apply the parking brake completely. The shift lever cannot be shifted from the "P" position with the 12-volt auxiliary battery disconnected.
- If the negative (-) terminal of the auxiliary battery is reconnected, even if the power switch is selected to the "START" mode, the hybrid system may NOT start. In this case, push the POWER switch to select "START" again to start the hybrid system (the "READY" light is ON). If the hybrid system still does NOT start (the "READY" light is OFF), refer to the Repair Manual.
- If the vehicle is equipped with VGRS, the system must be initialized after the auxiliary battery has been reconnected. Refer to the applicable vehicle specific Service Bulletin for instructions.

Maintenance for HV & Auxiliary Batteries

Maintenance Items

CONDITION*	MAINTENANCE OPERATION
Before Delivery	Fully charge the 12-volt auxiliary battery. Fast charge is NOT recommended on the 12-volt battery in order to prevent battery damage. (Deliver the vehicle to the customer after it is fully charged to 12.6 V.)
To Store for 30 Days or More	Disconnect the negative (-) terminal of the 12-volt auxiliary battery to prevent the SOC of the auxiliary battery from decreasing during storage due to parasitic current.
Just After Unloading & Every 2 Months	Keep the Hybrid System ON for 30 minutes with the transmission in the "P" position (in order to charge the HV battery and the auxiliary battery).

*The condition also corresponds with the section titles within this Service Bulletin.

Warranty Information

OP CODE	DESCRIPTION	TIME	OFF	T1	T2
N/A	Not Applicable to Warranty	-	-	-	-

Required Tools & Equipment

SPECIAL SERVICE TOOLS (SST)	PART NUMBER	QTY
GR8 Battery Diagnostic Station**	00002-MCGR8	1

* Essential SST.

NOTE

Additional SSTs may be ordered by calling 1-800-933-8335.

Before Delivery

1. Before charging the auxiliary battery, turn OFF ALL lights and accessories.
2. Locate the 12-volt auxiliary battery.

Maintenance for HV & Auxiliary Batteries

Before Delivery (Continued)

3. Remove the positive (+) terminal cover

Figure 1.

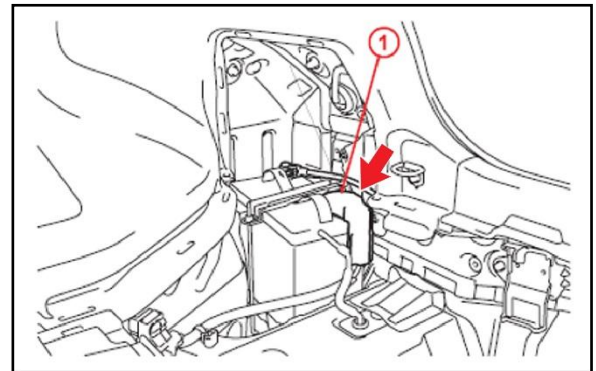

1	Positive (+) Terminal Cover
----------	------------------------------------

4. Check the battery SOC.
 - If the battery voltage is **LESS THAN** 12.6 V, then continue to step 5.
 - If the battery voltage is 12.6 V or MORE, replace the positive (+) terminal, close the battery cover, install the luggage compartment floor mat, and close the trunk.

CAUTION

If measuring the voltage with the negative (–) terminal connected, verify IG/OFF, and turn headlights ON for 60 seconds or more. This removes the surface charge.

5. Test the 12-volt auxiliary battery using the GR8 Battery Diagnostic Station. If charging is required, the GR8 will automatically start to charge.
 - A. Connect the red charger clamp to the positive (+) battery terminal and the black charger clamp to the negative (–) battery terminal.
 - B. Plug the charger into a grounded 110-volt outlet and flip the power switch to the “ON” position.

Figure 2. GR8 Battery Diagnostic Station

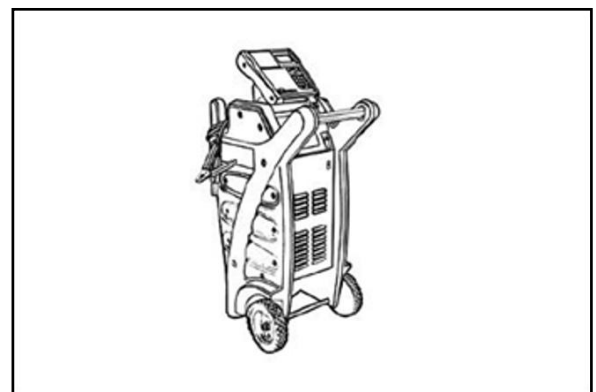

Maintenance for HV & Auxiliary Batteries

Before Delivery (Continued)

- C. Once the charger is properly turned ON, perform a diagnostic charge by “MODEL” (select the appropriate vehicle model). The GR8 Battery Diagnostic Station will indicate results when complete. If the battery tests bad (“Replace Battery”), replace the auxiliary battery.

NOTE

- If the vehicle model is NOT listed in the model list, charge by battery stock code. To charge by stock code, refer to the Lexus Battery Stock Number Chart located on the Technical Information System (TIS), *Diagnostics – Tools & Equipment – Battery Diagnostics*.
- If the auxiliary battery was stored at 32°F (0°C) or below, charge the auxiliary battery in a room above 32°F (0°C).

CAUTION

- Charge in a well-ventilated area.
- Do NOT allow sparks or fire near the auxiliary battery.

6. If the GR8 Battery Diagnostic Station is NOT available, you may charge the 12-volt battery by turning the vehicle to “READY” ON.
- Run time will vary depending on the SOC.
 - If this method is used, you MUST confirm that the battery is charged to 12.8 V using a DVOM.

To Store for 30 Days or More

Disconnect the Negative (–) Terminal:

1. Turn OFF ALL lights and accessories.
2. Disconnect the negative (–) terminal.

NOTE

When it is necessary to move the vehicle, reconnect the negative (–) terminal.

Figure 3.

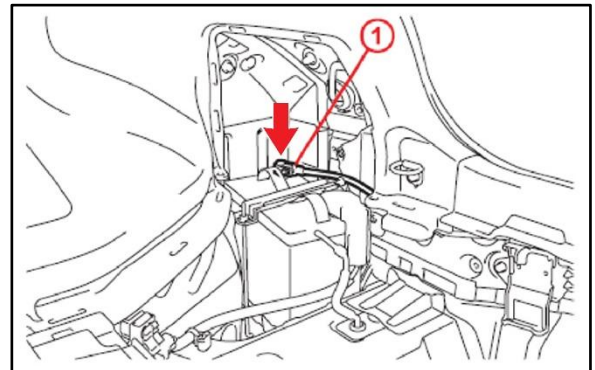

1 Negative (–) Terminal Cover

Maintenance for HV & Auxiliary Batteries

Every Two Months

Cycle Vehicle to “READY” ON:

NOTE

- When the remaining capacity of the HV battery is low, the gasoline engine automatically starts and the HV battery is charged. The 12-volt auxiliary battery is also charged by the HV battery regardless of the gasoline engine operation.
- Be sure to reconnect the negative (–) terminal of the auxiliary battery before performing this procedure.

1. Park the vehicle in open air or connect the exhaust extraction hose to the exhaust pipe.
2. Apply the parking brake.
3. With the brake pedal depressed, push the POWER switch and check that the “READY” light in the meter illuminates when the hybrid system starts (the “READY” light is ON).

Figure 4.

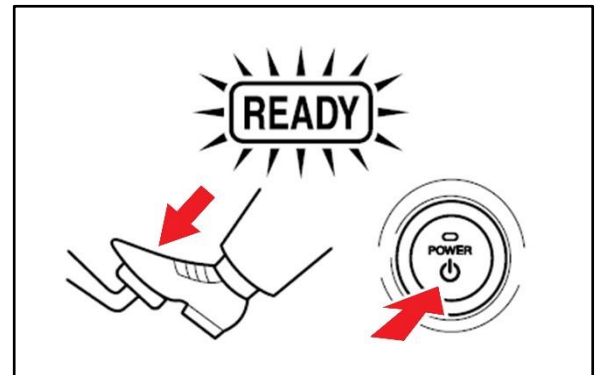

4. Turn OFF ALL lights and accessories.
5. Check that the shift lever is in the “P” position.

Maintenance for HV & Auxiliary Batteries

Every Two Months (Continued)

Cycle Vehicle to "READY" ON:

- Keep the "READY" light ON and charge the HV battery for 30 minutes.

NOTE

- If the amount of charging energy is small, the display may NOT indicate the energy flow.
- Ensure there is a sufficient amount of fuel for the vehicle to run for 30 minutes.

Figure 5.

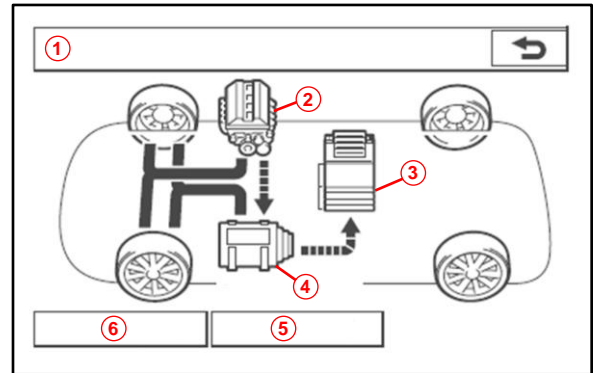

1	Energy Monitor
2	Engine
3	Battery
4	Electric Motor
5	Past Record
6	Consumption