

TOYOTA

**Updated 01/12/2017: Parts Ordering, Reimbursement Procedures
Sections & Technical Instructions Updated**

Toyota Motor Sales, U.S.A., Inc.
19001 South Western Avenue
Torrance, CA 90501
(310) 468-1000

TO: ALL TOYOTA DEALER PRINCIPALS,
SERVICE MANAGERS, AND PARTS
MANAGERS

SUBJECT: SPECIAL SERVICE CAMPAIGN (SSC) – 60E
(2005 THROUGH LATE 2006 MODEL YEAR TACOMA ACCESS CAB SUPPLEMENTAL
INFORMATION FOR INSTALLATION OF A CHILD RESTRAINT SYSTEM AND
CORRECTION TO THE TIRE AND LOADING INFORMATION LABEL)

Toyota will conduct a Special Service Campaign to provide involved vehicle owners with an updated Owner's Manual and a supplemental label regarding the installation of a Child Restraint System (CRS) in the rear auxiliary seat of the vehicle. The updated Owner's Manual and supplemental label is meant to better inform the owners of the correct CRS installation procedure, which includes flipping the rear auxiliary seat cushion forward.

The right rear auxiliary seat is also equipped with a child restraint anchorage system that is designed to be used with certain CRSs manufactured after 2002 which contain specialized attachment hardware. Older CRSs, as well as all booster seats, may be installed at either the left or right rear position using the vehicle's safety belts.

In addition, for specific late 2005 through late 2006 model year Tacoma vehicles which have a Tire and Loading Information Label that does not reflect the presence of the two auxiliary seats in the rear of the cabin, a new label will be mailed to the owners.

The following vital information is provided to inform you and your staff of the activity schedule and your degree of involvement.

1. **Owner Notification Mailing Date**

The owner notification will commence in late August, 2006.

Owner notifications will contain the updated Owner's Manual and applicable label(s). The owners will be requested to install these items on their vehicle. We request the assistance of Toyota dealerships if customers have any questions or request assistance in affixing the label(s).

Please note that only owners of the affected vehicles will be notified.

2. **Number and Identification of Involved Vehicles**

There are approximately 114,000 2005 through late 2006 Model Year Tacoma vehicles involved in the U.S.

3. **Vehicles in Dealer Stock**

Dealers are requested to replace the Owner's Manual and affix the applicable label(s) to any vehicle in their inventory prior to customer delivery. As vehicles are also being updated at NUMMI, please verify **eligibility by confirming through Dealer Daily/TIS prior to performing this SSC**. Dealers should perform the campaign work as outlined in the attached Technical Instructions.

4. **Dealer/Owner Lists**

As the updated Owner's Manual and applicable label(s) will be mailed directly to the vehicle owner, Dealer/Owner Lists will not be included for this SSC.

5. **Parts Ordering**

Owners of the specific 2005 through late 2006 model year Tacoma Access Cab vehicles had the updated Owner's Manual and applicable label(s) mailed directly to them.

If the updated Owner's Manual and applicable labels are not installed, they can be ordered through either NAPO or MDC as follows:

Supplier	Part Number	Description	Quantity
NAPO	74543-04011	Child Restraint Supplemental Label	1

Supplier	Part Number	Description	Quantity
MDC	00411-160002	Owner's Manual & Tire Placard (2005)	1
MDC	00411-160003	Owner's Manual & Tire Placard (2006)	1

Note: Follow the inspection procedure in the TI to determine which, if any, materials are needed.

6. **Repair Procedures**

Please refer to the attached Technical Instructions to repair the dealer stock units as well as any vehicle where a customer requests assistance.

7. **Reimbursement Procedures**

Submit warranty repair claims following the procedures described in the Toyota Warranty Policy and Procedures Manual.

The operation code(s) to be used for this activity are as follows:

Activity	Op. Code	Description	Flat Rate Hour
60E	QC60E1	Inspect, no action necessary, close campaign.	0.0 Hr/Veh
	6513F1	Replace the Owner's Manual and affix the Child Restraint System supplemental label.	0.2 Hr/Veh
	6513F2	Replace the Owner's Manual, affix the Child Restraint System supplemental label and correct the Tire Loading and Information	0.3 Hr/Veh

NOTE:

- Op. Codes 6513F1 & 6513F2 include 0.1 hours of administrative cost per unit for the dealership.
- The cost for Owner's Manual and CRS label can be claimed as sublet type zz under opcodes 6513F1 & 6513F2 for a maximum of \$5.00.

Please review this entire package with your Service and Parts staff to familiarize them with the proper step-by-step procedures required to implement this activity.

Thank you for your cooperation.

**SSC 60E - 2005 through late 2006 Model Year Tacoma Access Cab
Supplemental Information for Installation of a Child Restraint System**

Dear Toyota Tacoma Owner:

Thank you very much for your patronage of Toyota. We are dedicated to providing vehicles of outstanding quality and value. As part of our continuing efforts to provide superior customer satisfaction, Toyota is announcing a Special Service Campaign Program on certain 2005 through late 2006 model year Tacoma Access Cab vehicles to provide supplemental information on how to install a Child Restraint System ("CRS") in the rear area of the vehicle cabin.

What is the condition?

Your Tacoma Access Cab vehicle has been designed to maximize your cargo carrying capacity, yet afford a limited ability to carry additional passengers. To accomplish this task, the rear area of the cabin has been uniquely designed with two flip-over auxiliary seats. When installing a CRS in the rear of your vehicle, to assure appropriate stability, please flip over the bottom cushion of the auxiliary seat to create the cargo panel configuration and install the CRS on the resulting surface.

To ensure that any person installing a CRS in your vehicle is aware of these instructions, Toyota is providing you with a supplemental label to be installed in the rear of the cabin. In addition, Toyota is providing you with a replacement Owner's Manual, which contains additional information on the proper installation of a CRS in your vehicle.

Please note that the right rear auxiliary seat is equipped with a child restraint anchorage system that is designed to be used with certain CRSs manufactured after 2002 which contain specialized attachment hardware. Older CRSs, as well as all booster seats, may be installed at either the left or right rear position using the vehicle's safety belts.

What should you do?

Please replace your original Owner's Manual with the new one and dispose of the original manual to avoid confusion. The new Owner's Manual can be identified by an orange dot on the back cover. In addition, please affix the supplemental label that describes the proper way to install CRSs, in accordance with the enclosed instructions.

If you prefer, your local Toyota dealer will be more than happy to assist you in installing the label into your vehicle at **NO CHARGE**. If you choose to have the Toyota dealer affix the new label, please present this notice and the enclosed label to the dealer at the time of your appointment.

If you no longer own the vehicle, please indicate so on the enclosed postage paid form, providing us with the name and address of the new owner.

What if you have other questions?

Your local Toyota dealer will be more than happy to answer any of your questions and set up an appointment. If you require further assistance, you may contact the Toyota Customer Experience Center at 1-888-270-9371 Monday through Friday, 5:00 am to 9:30 pm, Saturday and Sunday 7:00 am through 3:00 pm Pacific Time.

We have sent this notice in the interest of your continued satisfaction with our products, and sincerely regret any inconvenience this may have caused you.

Thank you for driving a Toyota.

Sincerely,
TOYOTA MOTOR SALES, U.S.A., INC.

CRS Label Installation Instructions

1. CRS label installation location, see illustration below.

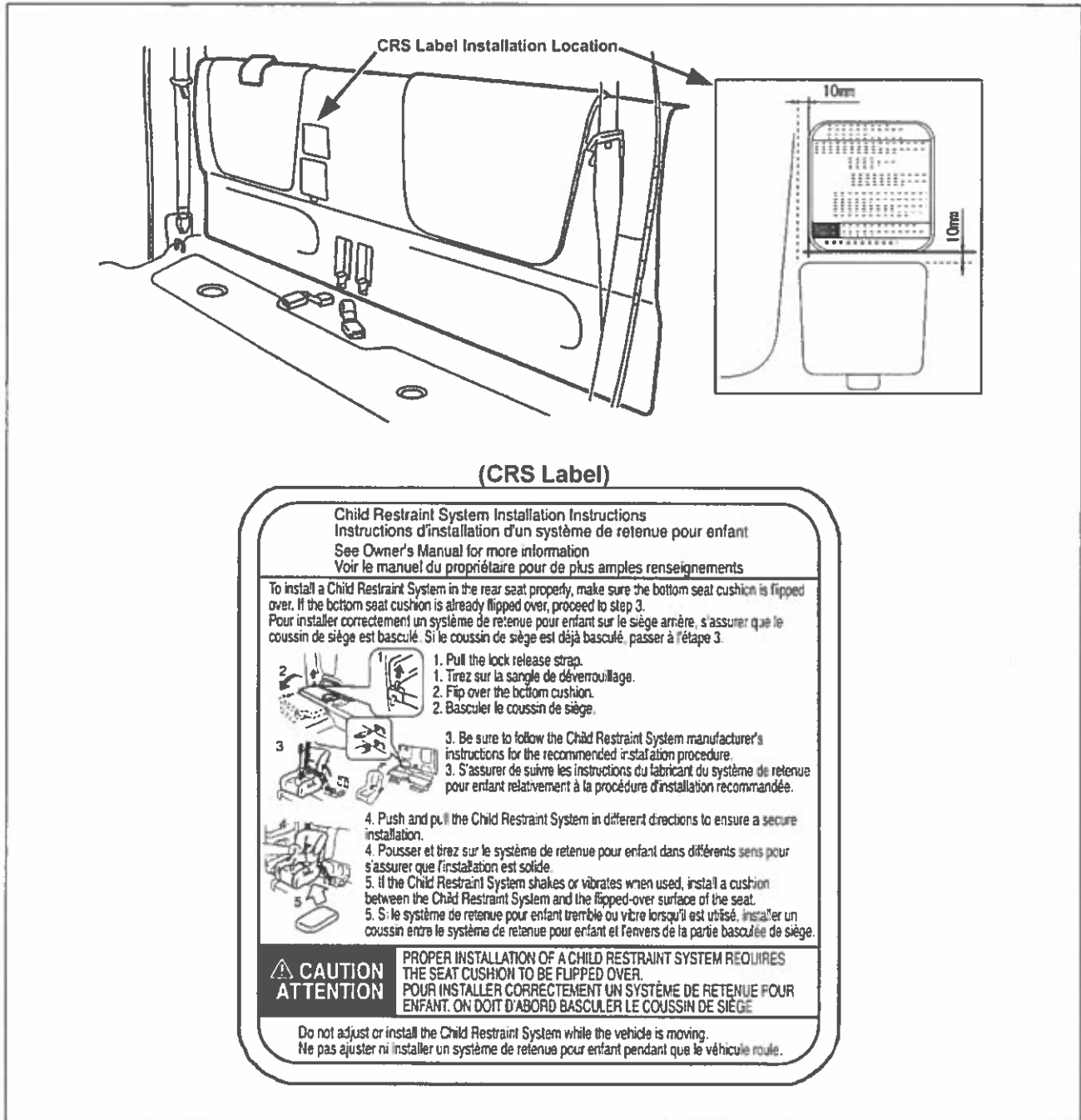

2. Wipe the area where the CRS label will be affixed with a clean, dry cloth to remove any dust or dirt.
3. Affix the CRS Label at the indicated location while smoothing out any air bubbles in the new label.

If you prefer, your local Toyota dealer will be more than happy to assist you in installing the label. If you choose to have the Toyota dealer affix the CRS label, please present this notice and the enclosed CRS Label to the dealer at the time of your appointment.

**SSC 60E - 2005 through late 2006 Model Year Tacoma Access Cab
Supplemental Information for Installation of a Child Restraint System and
Correction to the Tire and Loading Information Label**

Dear Toyota Tacoma Owner:

Thank you very much for your patronage of Toyota. We are dedicated to providing vehicles of outstanding quality and value. As part of our continuing efforts to provide superior customer satisfaction, Toyota is announcing a Special Service Campaign Program on certain 2005 to late 2006 model year Tacoma Access Cab vehicles to clarify as well as provide supplemental information on how to install a Child Restraint System ("CRS") in the rear area of the vehicle cabin. In addition, Toyota would like to correct an error that may exist on your vehicle's Tire and Loading Information Label ("tire label").

What is the condition?

Your Tacoma Access Cab vehicle has been designed to maximize your cargo carrying capacity, yet afford a limited ability to carry additional passengers. To accomplish this task, the rear area of the cabin has been uniquely designed with two flip-over auxiliary seats. When installing a CRS in the rear of your vehicle, to assure appropriate stability, please flip over the bottom cushion of the auxiliary seat to create the cargo panel configuration and install the CRS on the resulting surface.

To ensure that any person installing a CRS in your vehicle is aware of these instructions, Toyota is providing you with a supplemental label to be installed in the rear of the cabin. In addition, Toyota is providing you with a replacement Owner's Manual, which contains additional information on the proper installation of a CRS in your vehicle.

Please note that the right rear auxiliary seat is equipped with a child restraint anchorage system that is designed to be used with certain CRSs manufactured after 2002 which contain specialized attachment hardware. Older CRSs, as well as all booster seats, may be installed at either the left or right rear position using the vehicle's safety belts.

In addition to these concerns, due to a labeling error, the "seating capacity" specified on your vehicle's tire label may not reflect the two auxiliary seats in the rear of the vehicle. To correct this error, Toyota is enclosing a new tire label, which correctly reflects the vehicle's seating capacity (Total 4, Front 2, and Rear 2). Please note that this change does not affect the load-carrying capacity of your vehicle, as the combined weight of occupants and cargo should still never exceed the limit indicated on the label.

What should you do?

Please assist us by taking the following actions:

- Replace your original Owner's Manual with the new one and dispose of the original manual to avoid confusion. The new Owner's Manual can be identified by an orange dot on the back cover.
- Affix the supplemental label that describes the proper way to install CRSs, in accordance with the enclosed instructions.
- Examine the tire label on your vehicle, which can be located using the enclosed instructions. If it currently indicates that the total seating capacity is 2, please, affix the new tire label over the original label following the instructions provided.

If you prefer, your local Toyota dealer will be more than happy to assist you in installing the labels into your vehicle at **NO CHARGE**. If you choose to have the Toyota dealer affix the new label, please present this notice and the enclosed labels to the dealer at the time of your appointment.

If you no longer own the vehicle, please indicate so on the enclosed postage paid form, providing us with the name and address of the new owner.

What if you have other questions?

Your local Toyota dealer will be more than happy to answer any of your questions and set up an appointment. If you require further assistance, you may contact the Toyota Customer Experience Center at 1-888-270-9371 Monday through Friday, 5:00 am to 9:30 pm, Saturday and Sunday 7:00 am through 3:00 pm Pacific Time.

We have sent this notice in the interest of your continued satisfaction with our products, and sincerely regret any inconvenience this may have caused you.

Thank you for driving a Toyota.

Sincerely,
TOYOTA MOTOR SALES, U.S.A., INC.

Updated Tire and Loading Information Label Installation Instructions

1. Open the driver's door and the driver's side access cab door.
2. Locate the Tire and Loading Information Label, see illustration below.

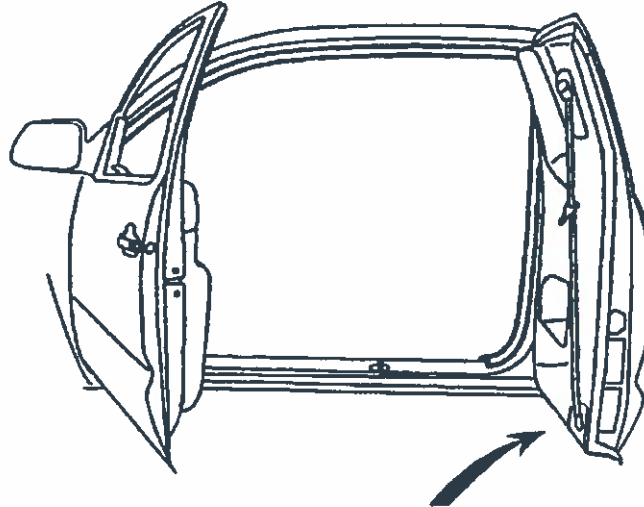

Tire and Loading Information Label Location

(New label with correct seating capacity information)



TIRE AND LOADING INFORMATION
SEE OWNER'S MANUAL FOR ADDITIONAL INFORMATION
RENSEIGNEMENTS RELATIFS AUX PNEUS ET A LA CHARGE DU VEHICULE

SEATING CAPACITY	TOTAL	FRONT
NOMBRE DE PLACES	TOTAL (4)	AVANT: 2
		REAR
		ARRIERE: 2

The combined weight of occupants and cargo should never exceed 3000 kg or 6600 lbs
La charge du véhicule (occupants et bagages) ne doit jamais dépasser 3000 kg or 6600 lbs

TIRE PNEUS	ORIGINAL TIRE SIZE DIMENSIONS DES PNEUS D'ORIGINE	COLD TIRE INFLATION PRESSURE PRESSION DE CONFLAGE A FROID
FRONT/AVANT	PXXX / XX RXX	XX PSI, XXX kPa
REAR/ARRIERE	PXXX / XX RXX	XX PSI, XXX kPa
SPARE/SECOURS	PXXX / XX RXX	SEE ABOVE/VOIR CI DESSUS



XXX

3. Wipe the area where the new label will be affixed with a clean, dry cloth to remove any dust or dirt.

NOTE:

The new Tire and Loading Information Label includes only the section of information that has been updated, the remaining portions of the label are clear plastic.

4. Affix the new Tire and Loading Information Label over the old label while smoothing out any air bubbles in the new label.

If you prefer, your local Toyota dealer will be more than happy to assist you in installing the label. If you choose to have the Toyota dealer affix the new label, please present this notice and the enclosed Tire and Loading Information Label to the dealer at the time of your appointment.

CRS Label Installation Instructions

1. CRS label installation location, see illustration below.

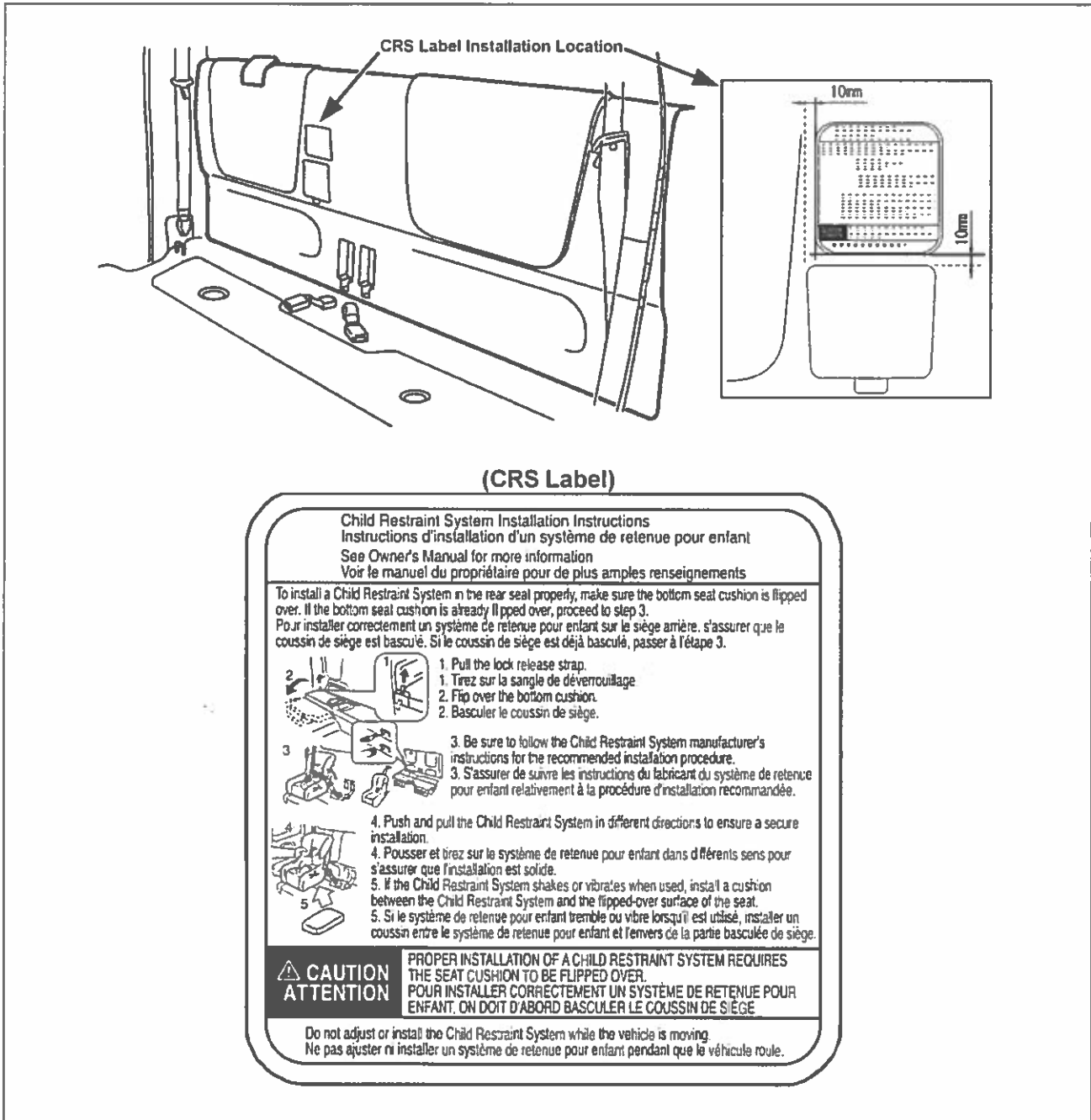

2. Wipe the area where the CRS label will be affixed with a clean, dry cloth to remove any dust or dirt.
3. Affix the CRS Label at the indicated location while smoothing out any air bubbles in the new label.

If you prefer, your local Toyota dealer will be more than happy to assist you in installing the label. If you choose to have the Toyota dealer affix the CRS label, please present this notice and the enclosed CRS Label to the dealer at the time of your appointment.



**Special Service Campaign (SSC) 60E Q&A
2005 through late 2006 Model Year Tacoma Access Cab
Child Restraint System & Tire and Loading Information Label**

Q1: What is the condition?

A1: Toyota will conduct a Special Service Campaign to provide involved vehicle owners with an updated Owner's Manual and a supplemental label regarding the installation of a Child Restraint System (CRS) in the rear auxiliary seats of the vehicle. The updated Owner's Manual and supplemental label sent to owners is meant to better inform the owners of the correct CRS installation procedure, which includes flipping the rear auxiliary seat cushion forward.

The right rear auxiliary seat is also equipped with a child restraint anchorage system that is designed to be used with certain CRSs manufactured after 2002 which contain specialized attachment hardware. Older CRSs, as well as all booster seats, may be installed at either the left or right rear position using the vehicle's safety belts.

In addition, for specific late 2005 through late 2006 model year Tacoma vehicles which have a Tire and Loading Information Label that does not reflect the presence of the two auxiliary seats in the rear of the cabin, a new label will be mailed to the owners.

Q2: Which and how many vehicles are involved?

A2: There are approximately 114,000 2005 through late 2006 Model Year Tacoma Access cab vehicles involved in the U.S.

Q3: What is the production period of the affected vehicles?

A3: The affected Tacoma Access cab vehicles were produced from mid September 2004 to early June 2006.

Q4: Are there any other Toyota, Lexus or Scion vehicles involved?

A4: No, this specific condition only affects certain 2005 through late 2006 model year Tacoma Access cab vehicles.

Q5: How many incidents of this condition have been reported?

A5: There have been no cases of this condition reported in the affected vehicles.

Q6: Have there been any accidents reported?

A6: There have been no reported cases of accidents in the affected vehicles which may relate to this condition.

Q7: Have there been any injuries related to the alleged accidents?

A7: There have been no reported cases of injuries related to this condition reported in the affected vehicles.

Q8: What is Toyota going to do?

A8: Owners of the involved vehicles will receive the updated Owner's Manual and the supplemental label regarding the installation of a Child Restraint System (CRS) by first class mail. In addition, for specific late 2005 through late 2006 model year Tacoma vehicles which have a Tire and Loading Information Label that does not reflect the presence of the two auxiliary seats in the rear of the cabin, an additional new label will be mailed to the owners. Owners will be requested to replace the Owner's Manual and affix the label(s). Toyota dealers will assist customers who prefer to have the dealer to perform the installation of the label(s) at **NO CHARGE** to the vehicle owners.

Q9: How long will the repair take?

A9: Installing the label(s) will only require a few minutes. However, depending upon the dealer's work schedule, it may be necessary to make the vehicle available for a longer period of time.

[For Toyota Dealers Only]

Q10: Didn't Toyota launch a similar campaign on Tacoma Access Cab vehicles late last year changing the Tire Information Label from "Total 4 (Front 2, Rear 2)" to "Total 2 (Front 2, Rear 0)"?

A10: Yes, Toyota launched SSC 50R in late October/early November 2005. However, since that time, it has been determined the *two rear auxiliary seating positions should be included* in the total number of seating positions, and therefore, SSC 50R has been removed from TIS and the updating of certain late 2005 through late 2006 model year Tacoma Access Cab vehicle's Tire Information Label has been incorporated into SSC 60E. This in effect reverses SSC 50R.

