

# **COLD CLIMATE STATES ONLY**

*CT, DE, IL, IN, KY, MA, MD, ME, MI, MN, NH, NJ, NY, OH, PA, RI, VA, VT, WI & WV and District of Columbia*

## **TECHNICAL INSTRUCTIONS**

**FOR**

**CORROSION-RESISTANT COMPOUND CAMPAIGN H0F**

**CERTAIN 2005 THROUGH 2010 MODEL YEAR TACOMA**

**CORROSION-RESISTANT COMPOUND APPLICATION**

# **COLD CLIMATE STATES ONLY**

*CT, DE, IL, IN, KY, MA, MD, ME, MI, MN, NH, NJ, NY, OH, PA, RI, VA, VT, WI & WV*

The repair quality of covered vehicles is extremely important to Toyota. All dealership technicians performing this repair are required to successfully complete the most current version of the E-Learning course "Safety Recall and Service Campaign Essentials". To ensure that all vehicles have the repair performed correctly, technicians performing this repair are required to currently hold at least one of the following certification levels:

- Certified Technician and above

Always check which technicians can perform the recall remedy by logging on to <https://www.utodealerreports.com>. It is the dealership's responsibility to select technicians with the above certification level or greater to perform this repair. Carefully review your resources, the technician skill level, and ability before assigning technicians to this repair. It is important to consider technician days off and vacation schedules to ensure there are properly trained technicians available to perform this repair at all times.



- For a complete list of Site Selection Guidelines and, Fire, Building, and Zoning Codes information for your state, please refer to the Dealer Information Packet. Please ensure your dealership complies with all regulations set forth in this packet.
- Keep records to comply with Federal/State/Local regulations and requirements. See the Federal, State & Local Requirements Guide and any Supplements to that Guide.

## I. OPERATION FLOW CHART

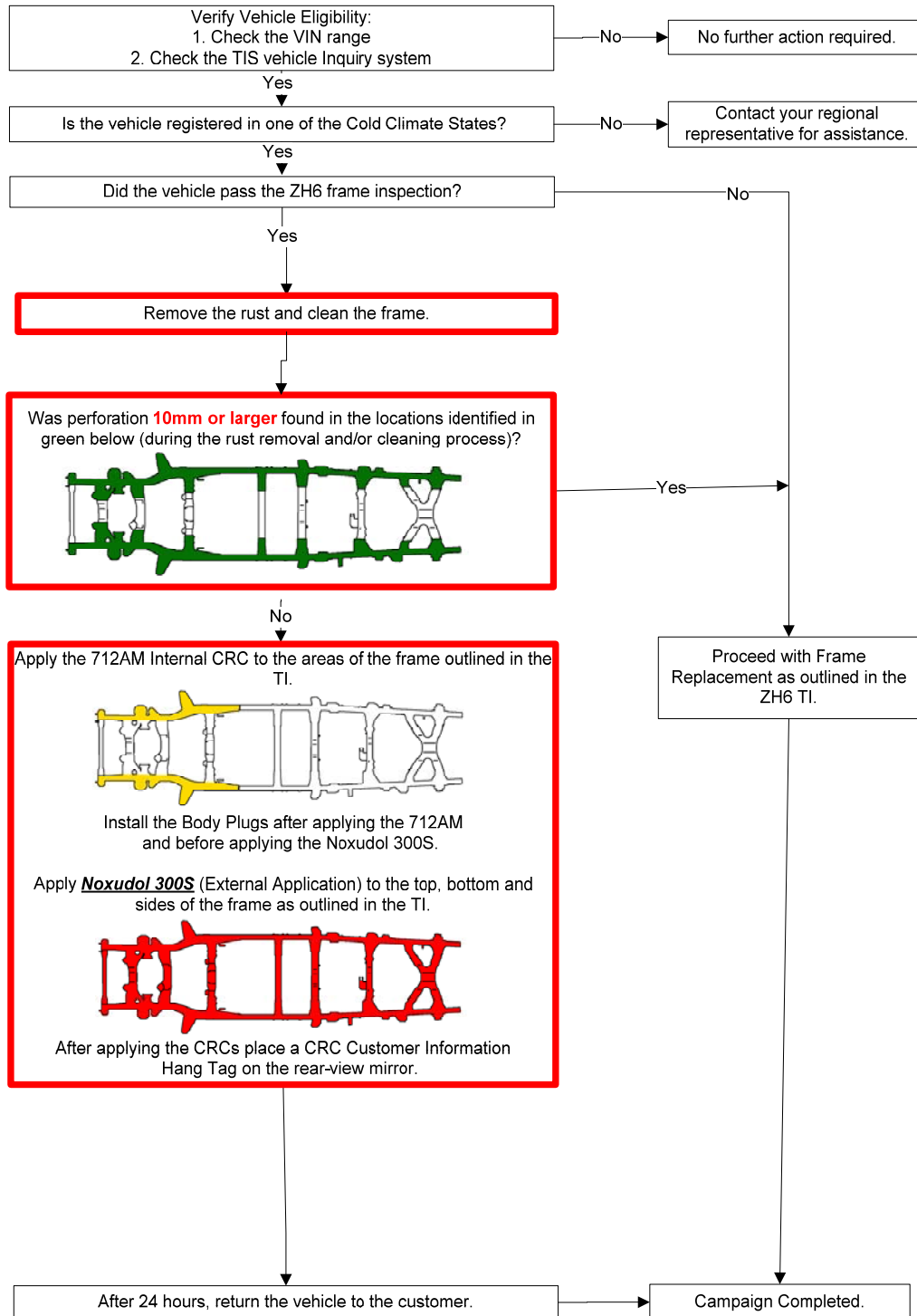

**Note:** Ensure to follow the entire procedure and perform all steps completely (e.g. cleaning/rust removal, CRC application, one kit per vehicle, etc.) any deviation will be subject to warranty claim debit.

## II. IDENTIFICATION OF COVERED VEHICLES

### A. COVERED VIN RANGE

**Notes:**

- Vehicles currently registered in the Cold Climate States\* or the District of Columbia (D.C.) that do not have significant corrosion found are eligible for Corrosion-Resistant Compound (CRC) application to the frame if it did NOT previously have the frame sprayed and/or had the frame previously replaced.
- Check TIS to confirm the VIN is covered in H0F. This will verify the vehicle is covered and has not already been completed prior to dealer shipment or by another dealer.
- TMS warranty will not reimburse dealers for repairs conducted on vehicles that are not covered or were completed by another dealer.

\* CT, DE, IL, IN, KY, MA, MD, ME, MI, MN, NH, NJ, NY, OH, PA, RI, VA, VT, WI, & WV

## III. PREPARATION

### A. PARTS

Please be aware that only dealers in Cold Climate States will be allowed to order the following CRC kit. The necessary CRC kits can be ordered through the chemical program provided by Dealer Tire (Complete Maintenance Care). The CRC kits will be shipped directly from AMREP. Your dealership should not order kits until you have confirmed an appointment. However, please keep in mind it will take at least 5 business days for CRC kit delivery. Deliveries are only scheduled on business days. Saturday deliveries are not available.

Model	Part No.	Part Description	Qty/Unit
Tacoma	00289-T00KT-DS	T00-Corros Res Kit (CRC Kit)	1
<u>The kit above includes the following parts:</u> Noxudol 300S – 3 Liters Parker 712AM – 1 Liter			

**1. When Ordering CRC Kits Please Note:**

- Each kit will contain the exact amount of CRC for one vehicle.
- The CRC kits listed will be drop-shipped from AMREP, not your local PDC. Do not order more than your immediate needs, as these materials are not returnable or refundable.
- Orders for these parts should be placed separately from orders of other drop ship chemicals.
- Refer to the Appendix for the Material Safety Data Sheet (SDS).

**2. When Storing the CRC Kits Please Note:**

- Follow local, state and federal regulations for hazardous materials storage and disposal that are explained in the Hazardous Waste Management Section of the Federal, State and Local Requirements Guide of the Dealer Information Packet.
- Store the CRC kits at room temperature (refer to the MSDS for detailed instructions).

**B. SUPPORT MATERIALS**

- The following support materials can be ordered through the dealer's facing **PDC**:

Part Number	Part Description	Quantity
5411A-04010	Frame Side Rail Seal, RH	1
5411B-04010	Frame Side Rail Seal, LH	1
90105-08500	Bolt, Flange	2
94611-10800	Washer	4
94151-80801	Nut w/Flange	2
94183-00831	Lock Nut	2
90178-A1008	Plug, Hole	2
90178-A1009	Plug, Hole	2
90119-A0169	Bolt,w/Washer	2
<b>The kit listed above includes the following parts:</b>		
04007-18335	Plug Hole Kit CRC Application	1
<b>The kit listed above includes the following parts:</b>		
<b>Part Number</b>	<b>Part Description</b>	<b>Qty</b>
90950-01A24	PLUG,HOLE	2
90950-01984	PLUG,HOLE	2
90950-01987	PLUG,HOLE	8
90950-01631	PLUG,HOLE	4
90950-01983	PLUG,HOLE	4
90950-01989	PLUG,HOLE	4
90950-01990	PLUG,HOLE	4
90950-01992	PLUG,HOLE	2
90950-01991	PLUG,HOLE	4
90950-01A09	PLUG,HOLE	2
90950-01931	PLUG,HOLE	1
90950-01A11	PLUG,HOLE	2
90389-05012	PLUG,HOLE	2
04007-23104	Plug Hole Kit CRC Application	1
<b>The kit listed above includes the following parts:</b>		
<b>Part Number</b>	<b>Part Description</b>	<b>Qty</b>
90950-A1008	PLUG,HOLE	2
90950-A1009	PLUG,HOLE	2
90080-46327	CLIP	2
90119-A0169	BOLT w/WASHER	4

- The following support materials can be ordered through the **MDC**:

Part Number	Part Description	Qty
00411-11004	Corrosion-Resistant Compound Customer Information Hang Tag*	1 per vehicle

\* Additional CRC Customer Information Hang Tags can be ordered in packages of 25 through the MDC.

**C. STANDARD TOOLS & EQUIPMENT**

- Standard hand tools
- Flat chisel
- Scraper
- Wire brush
- Air nozzle
- Infrared thermometer
- Air coupler (quantity 2)

## SPECIAL EQUIPMENT

The following equipment was shipped to your dealership prior to the launch of LSC H0F.

**Note: Due to federal, state and local regulations, each dealer is only allowed to have one set of spray guns. Any old previous spray guns from previous campaigns should be disposed of in accordance with local regulations.**

As a result, each participating dealer will have 2 total spray guns in their possession:

Equipment	Purpose	Application Area
Spray Gun	Noxudol 300S	Exterior Frame CRC Application
Spray Gun	712AM	Interior Frame CRC Application
90° Drill Adapter	Drill Holes	These tools will be used to attach the frame side rail seal.
Drill Bits	Drill Holes	

The items below were previously shipped to your dealership for previous CRC campaigns.

### Magnet Kit

- 30 Rare Earth Magnets – See section VI.C.1 “Attach Plastic Sheet” for details.

\*Follow the CRC Support link located in the left bottom corner of the C.L.E.A.N DEALER webpage.

## D. MATERIALS & SUPPLIES (Locally Procured by Dealer)

- Protective eyewear
- Dust mask
- Appropriate NIOSH approved respirator\*\* (Follow all Federal, State, Local Environmental, Health and Safety Requirements such as OSHA Regulations. Please refer to the SDS for details on the appropriate mask for each CRC.)



Example of a NIOSH-approved respirator

### \*\*Notes:

- Refer to the SDS located in the Appendix for additional information on respirator use.
- It is up to the individual dealership to ensure compliance with OSHA regulations.
- If you require further assistance in regards to NIOSH approved respirators, we have found 3M® to be a useful reference/source.

3M® Technical Assistance: 1-800-243-4630

3M® Customer Service: 1-800-328-1667

3M® Web Site: [www.3m.com/occsafety](http://www.3m.com/occsafety)

- Protective gloves
- Chemical Resistant Gloves (refer to SDS for specific type)
- Masking tape
- Duct tape
- Fire-retardant poly sheeting (tarp) or covering (if you cannot purchase the tarp from a local supplier, please refer to **CRC Tips and Examples** located on the C.L.E.A.N. DEALER website (<http://cleandealer.com>) for a list of possible suppliers)
- Plastic (Saran Wrap) sheet (for spray gun storage)
- Partitions (The type, size, and number of partitions used will depend on each dealer's facility.)
- Shop cloth/paper towels
- Funnel (quantity = 2)
- Plastic sheet to contain the dripping 712AM during frame application, 3m x 3m (118in x 118in)
- Garbage Bags

## IV. BACKGROUND AND COMPONENTS

Toyota has received a number of reports regarding Frame Corrosion on 2005 – 2010 model year Tacoma vehicles, 2007-2008 Tundra vehicles, and 2005-2008 Sequoia vehicles. In these reports, customers have indicated that vehicles operated in specific cold climate areas with high road salt usage may exhibit more-than-normal corrosion to the vehicle's frame. This condition is unrelated to and separate from normal surface rust which is commonly found on metallic surfaces after some years of usage and/or exposure to the environment.

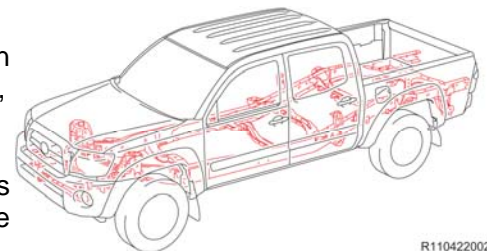

R1104220022



- Because of variations in State and local laws, dealerships conducting HOF in certain states may require government approvals prior to starting the campaign. Depending upon the state, dealerships also may be subject to restrictions on the number of vehicles to which the CRC can be applied in any single day, week, or month. Please refer to the Dealer Information Packet and any Supplements for important information about any such approvals or restrictions that may apply to your dealership. Your dealership must adhere strictly to these requirements.
- For a complete list of Site Selection Guidelines, Fire, Building, and Zoning Codes information for your state, please refer to the Dealer Information Packet as well as any Supplements. Please ensure your dealership complies with all regulations and all issued packets/instructions.

## V. VEHICLE INSPECTION WORK PROCEDURE

Note: Vehicle frame inspection is performed under WEP ZH6, for inspection instructions go to WEP ZH6 Technical Instructions.

## VI. FRAME APPLICATION WORK PROCEDURE



Allow sufficient time for the vehicle and exhaust to cool down before beginning the application process. By following the FRAME APPLICATION WORK PROCEDURE in these Technical Instructions, the vehicle will have additional time to cool before the CRC's are applied. Please refer to the SDS (In the Appendix) for flash point temp.

### A. VEHICLE PREPARATION AND REMOVAL OF FRAME RUST

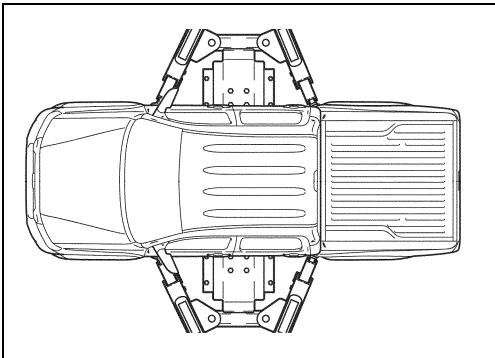

#### 1. PREPARE THE VEHICLE

- It may be necessary to pressure wash the vehicle's frame, depending on its cleanliness.

**Note:** Time has been allotted to pressure wash the frame in the flat rate time.

- Place the vehicle on the lift.



Strap the vehicle to the lift with safety straps. Once the vehicle is raised to the desired height, install screw jacks to the front and back of the vehicle.

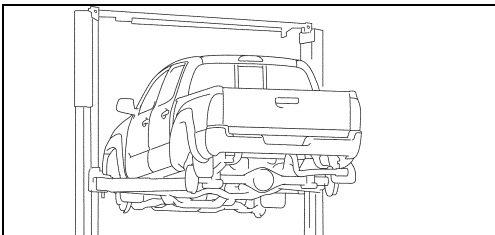

- Raise up the vehicle and remove the wheels.
- Remove the engine under cover.
- Cover any identifying label (i.e., VIN label, etc.) on the frame with tape.
- Cover all exposed electrical connectors with tape to protect from over spray.

#### 2. REMOVE RUST FROM THE FRAME AND CROSS-MEMBERS.

- Using a scraper or chisel remove all loose rust and rust scales from the frame and cross-members.

**Note:** The use of power tools is permissible during the cleaning process. Toyota found air scalers to work well.

- If rust perforation of 10mm or larger and/or component corrosion damage is found during the rust removal process proceed with frame replacement as outlined in the separate ZH6 TI.

#### Notes:

- Make sure to wear protective eyewear, gloves, and a dust mask when removing rust and cleaning frame.
- Be careful not to damage the wire harness or brake lines when removing rust.
- Be extremely cautious not to injure your hands.
- DO NOT scratch or remove the identifying labels

**Power Tools are Permissible**



ex.) Air Needle Scaler



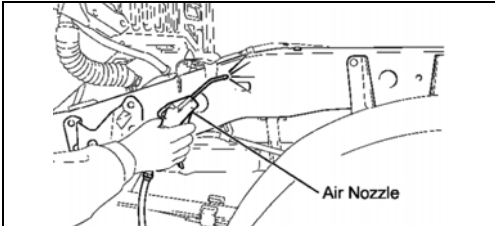
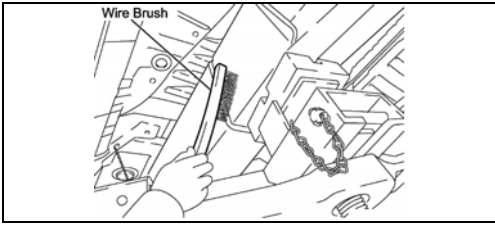

### 3. CLEAN THE FRAME

- a) Use a wire brush and remove any remaining rust or dirt from the frame.

Ensure to follow the procedure and perform all steps completely (e.g. inspection, cleaning/rust removal, CRC application, one kit per vehicle, etc.) any deviation will be subject to warranty claim debit.

- b) Use an air nozzle and remove any loose rust.

#### Notes:

- Make sure to wear protective eyewear, gloves, and a dust mask when performing this step.
- A slightly wet frame surface (no water droplets) is acceptable when applying the frame CRC.

#### Sample of Sufficient Frame Cleaning



## B. VEHICLE PROTECTION

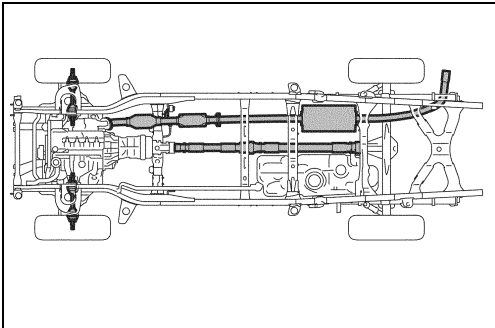

### 1. ATTACH MASKING MATERIALS

- a) Using an infrared thermometer ensure the exhaust has cooled.
- b) Cover the driveshaft(s) and exhaust, with fire-retardant poly sheeting (tarp) and secure with masking tape.
- c) Cover the front and rear brake/hub assemblies with garbage bags and secure with masking tape.

#### Notes:

- If necessary, cover shock absorbers with masking sheets.
- Overspray onto the driveshaft may cause vehicle vibration.

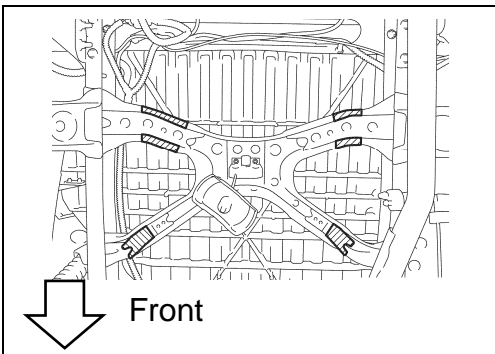

### 2. COVER SPARE TIRE CONTACT SURFACES ON REAR CROSS-MEMBER

- a) Cover the underside of the rear cross-member with duct tape where the spare tire contacts the rear cross-member.

#### Notes:

- Tape size/location may vary if the customer has changed spare tire size, adjust as necessary.
- Tape will not be centered on cross-member because spare tire carrier is off center.
- Tape will prevent Noxudol 300S from sticking to the tire.

## C. PREPARE FOR APPLICATION OF CORROSION-RESISTANT COMPOUND (CRC)

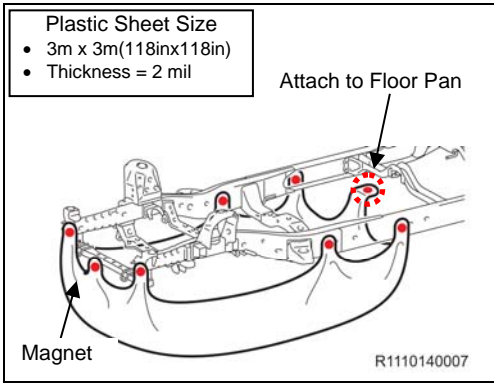

**Note: Always utilize the correct CRC kit for Tacoma CRC Application, Part Number 00289-T00KT-DS.**

### 1. ATTACH PLASTIC SHEET

- Before spraying 712AM to the internal frame, fit the plastic sheet on the frame utilizing the previously supplied magnet kit.

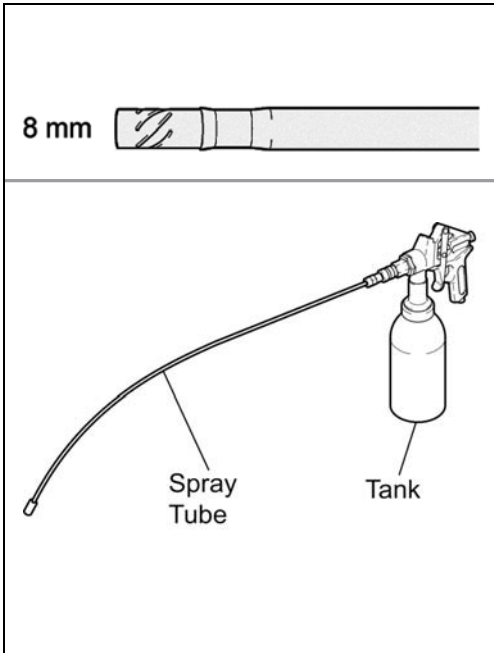

### 2. SET UP THE SPRAY GUN FOR 712AM INTERNAL CRC APPLICATION

**Notes:**

- Use a dedicated spray gun for the 712AM internal CRC.
- Make sure to wear protective eyewear, impervious gloves (Viton, PVOH, etc.) appropriate Niosh approved respirator, and refer to the MSDS located in the Appendix when handling and spraying CRC.

- Check the temperature of the 712AM.

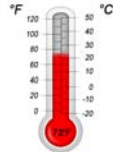

**If the 712AM is below 72° F, place the 712AM container in a bucket of hot water (<104° F) for 15 minutes and allow it to warm so the proper viscosity is achieved.**

- Shake the 712AM container well so that the contents are mixed thoroughly. Settling may occur as it sits over time.
- Fill the dedicated tank with 712AM and attach it to the spray gun.
- Connect the 8mm spray tube, as shown in the illustration.
- Adjust the spray gun nozzle flow/volume.

- Turn the adjustment screw to the fully closed position (clockwise).
- Then loosen the adjustment screw **4** complete turns.

**STOP The air regulator is extremely sensitive; always follow instruction to avoid damage to the gun!**

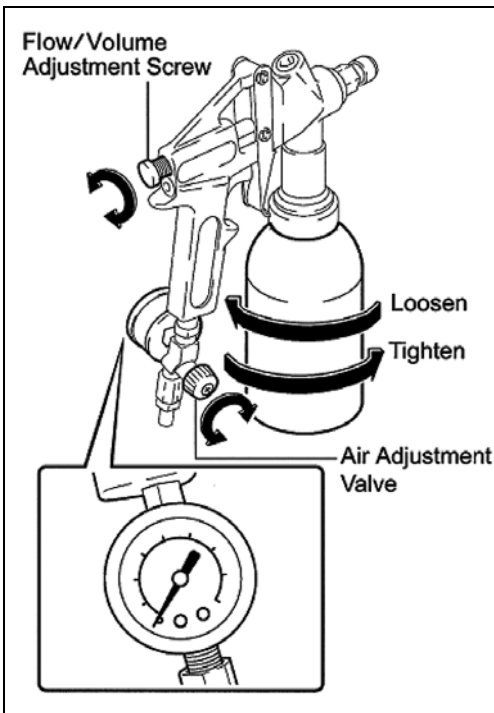

- Adjust the air pressure regulator.

- Place the nozzle in a clean empty box or pail.
- Adjust the air regulator completely closed (No Air Flow)
- Attach the air hose to gun.
- Fully press the spray gun trigger, and slowly adjust the air pressure to 72.5 psi.

**Note: The air regulator has a slight delay and may take up to 10 seconds before the air pressure stabilizes. Move the adjustment knob in very small increments (1/8 turn).**

- Recycle the amount sprayed out and use it during the application process.



## D. 712AM INTERNAL FRAME CRC APPLICATION

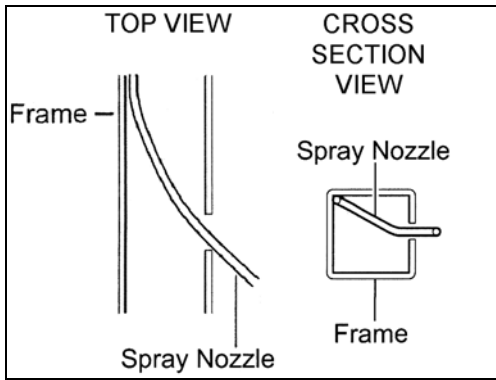

### 1. 712AM INTERNAL FRAME APPLICATION

- Insert the spray nozzle into the selected holes located throughout the frame. Reference the next page for the location, depth, and application rate.
- Note: DO NOT bend (i.e., kink) the spray nozzle.**
- Once the location, depth, and application rate is confirmed, begin applying CRC to the internal frame.
  - When inserting the nozzle, insert so the nozzle touches the opposite side of the frame as illustrated on the left. See Diagram 1 & 2 for applying CRC.

**Note: Make sure the quick coupler on the spray tube does not come into contact with the frame when applying the 712AM. Contacting the frame with the quick coupler may lead to a hose disconnection.**

- After the 712 AM has been applied, wipe away any wax on the frame's exterior with cloths or paper towels.

#### Notes:

- Follow all MSDS guidelines for the 712AM which can be found in the Appendix.
- Follow the given application speeds when applying the 712AM to the inner surface of the frame.
- The exact insertion point locations may vary depending on the cab configuration.

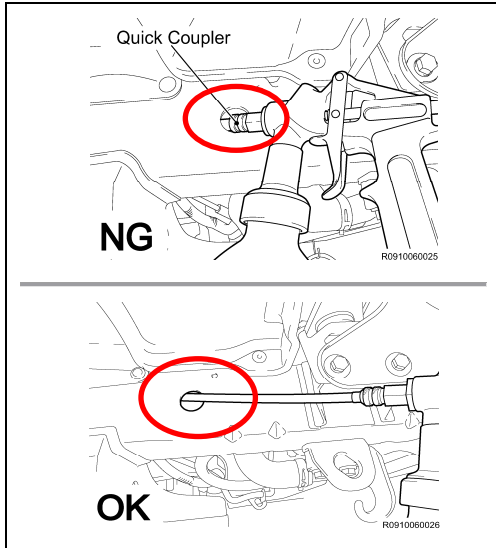

# Diagram 1: Internal CRC Application



## 712AM Internal CRC Application Tube Insert Locations, Depth, and Application Speed

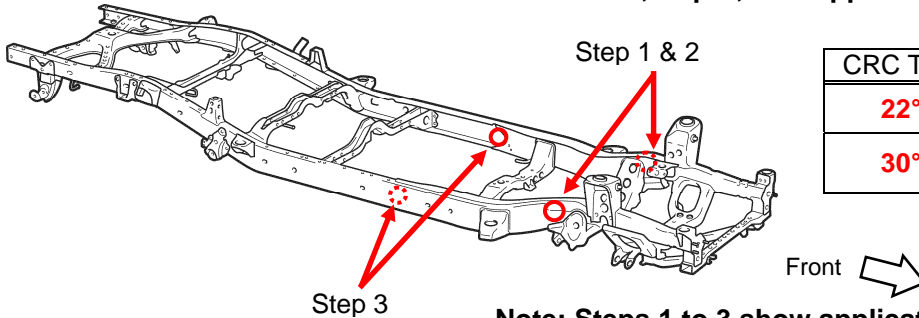

CRC Temperature	Application Speed
22°C (72°F)	0.2 m/sec (8 in/sec)
30°C (86°F)	0.3 m/sec (12 in/sec)

Note: m/sec = meters/second

Note: Steps 1 to 3 show application procedure only for the right side of the vehicle. Perform application for the left side of the vehicle in a similar manner.

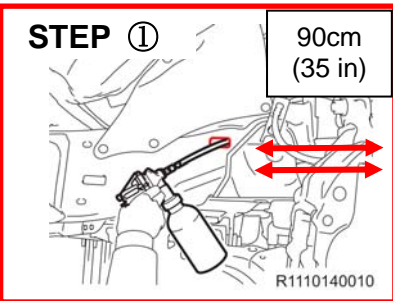

**Step 1 (refer to the table above for application rate):**

- While applying the 712AM, insert the nozzle 90cm (35 in) into the side-rail.
- Continue applying the 712AM while removing the nozzle.

Repeat Step 1 for a total of 2 laps

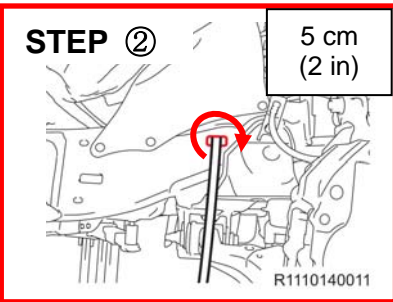

**Step 2 (refer to the table above for application rate):**

- Insert the nozzle 5 cm (2 in.) towards the front of the frame.
- Move the nozzle in a circular motion while applying the 712AM.

Note: Make sure to only insert the nozzle 5cm (2 in) to avoid over spraying onto the engine.

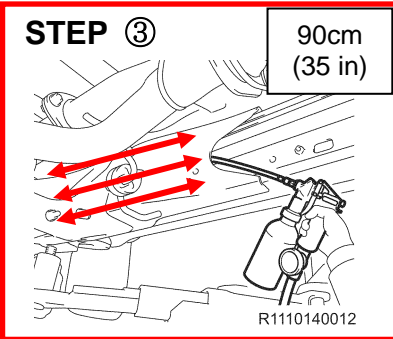

**Step 3 (refer to the table above for application rate):**

- While applying the 712AM, insert the nozzle 90cm (35 in) into the side-rail. (contact the top center of the frame while inserting nozzle).
- Continue applying the 712AM while removing the nozzle.

Repeat Step 3 for a total of 3 laps

**STOP THE ENTIRE LITER OF 712AM MUST BE APPLIED TO THE FRAME OF THE VEHICLE! STOP**

**Notes:**

- Follow all SDS guidelines for the 712AM which can be found in the Appendix.
- Only one side is given. Tube insert locations are the same for both sides.
- Follow the given application speeds when applying the 712AM to the inner surface of the frame. The exact insertion point locations may vary depending on the cab configuration.

## 2. REMOVE THE PLASTIC SHEET

- Let the 712AM complete dripping.
- With a cloth wipe off any drips of 712AM dripping from the frame.
- Before installing the body plugs, confirm that the excess 712AM has stopped dripping from the frame.

## E. INSTALLATION OF BODY PLUGS AND FRAME SEAL

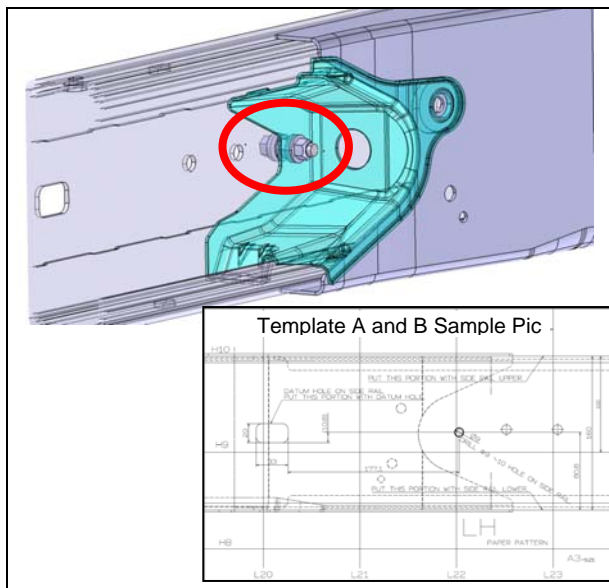

### 1. INSTALL FRAME RAIL SEAL

**Note: Due to the interference of key vehicle components, the frame seal will need to be modified to be installed onto the outer frame rail.**

- Using Template A & B in the appendix, locate the location on both outer frame side rails.
  - Print Template on 8.5" x 11" paper
  - Cut the template out
  - Align the template with the datum hole
  - Mark location of hole on outer frame side rail
- Use a center pin punch to create a dimple for the drill bit so it will not wander during drilling.
- Using the 90° drill adapter provided and the stepper bit, drill a 9mm (3/8") hole in the outer frame side rail as shown.
- Repeat procedure for opposite side frame rail.
- Using Template C and D, modify both the left and right side frame seal by drilling a (3/8") hole in the location shown.

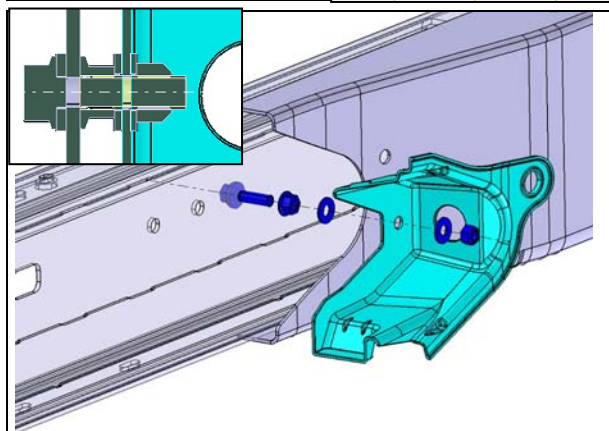
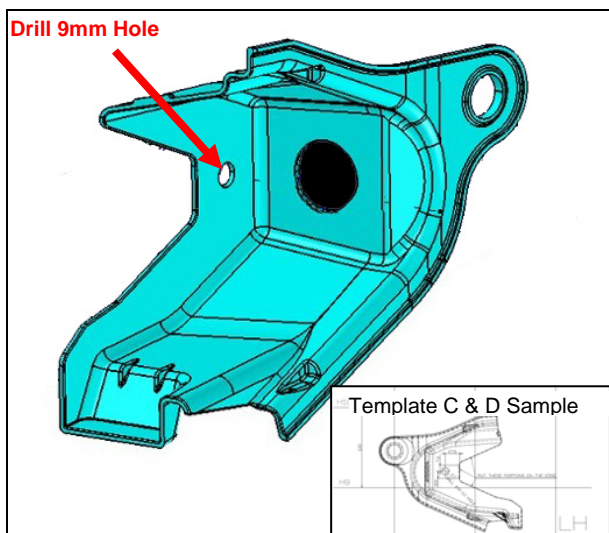

- Install the bolt through the frame and torque the flange nut.

**Torque Spec: 18.5 N·m (13.5 ft·lbf)**

- Install the washer onto the bolt.
- Install the frame seal second washer and locking nut onto the frame and torque to spec.

**Torque Spec: 6 N·m (52 in·lbf)**

Part #	Part Name	Qty
90105-08500	Bolt, Flange	2
94611-10800	Washer	4
94151-80801	Nut w/Flange	2
94183-00831	Lock Nut	2

## 1. INSTALL THE BODY PLUGS

- Body plug locations are symmetrical unless noted. The instructions only show one side, ensure you install in both locations.
- Install the plugs for prevention of dripping and water entry.

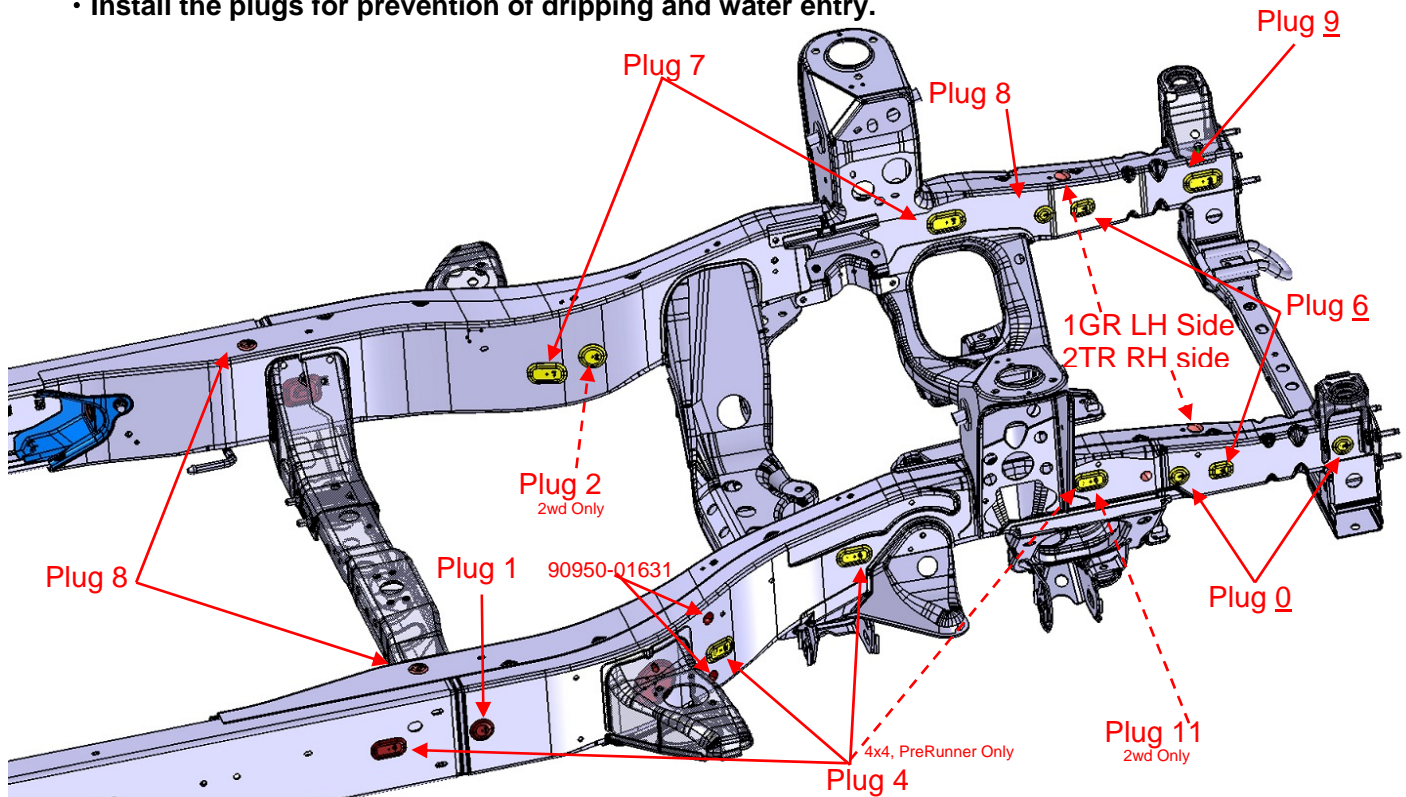



PLUG DIAGRAM/ID	P/N	INSTALLATION INSTRUCTIONS	TOTAL QTY
	90950-01992	Push to seat installation  Note: This is a one time install plug, it will break if you try to remove.	2
	90950-01983		4
	90950-01990	Push to seat install. There are two callout locations for this plug.	4
	90950-01984	Push to seat installation.	2
	90950-01989		4
	90950-01931	Engine variation determines which rail to install plug on.	1
	90950-01991	Push to seat installation Note: This is a one time install plug, it will break if you try to remove.	4
	90950-01987	Dashed line indicates part vary by vehicle type or configuration.	8 FOR 4WD 6 FOR 2WD
	90950-01A09	2wd Only Order separately	1
	90950-01A11	2WD ONLY	2
	90950-01631	Push to seat installation.	4

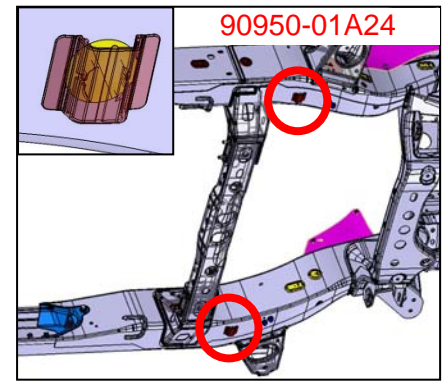
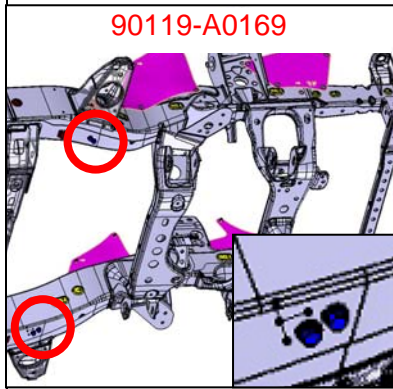
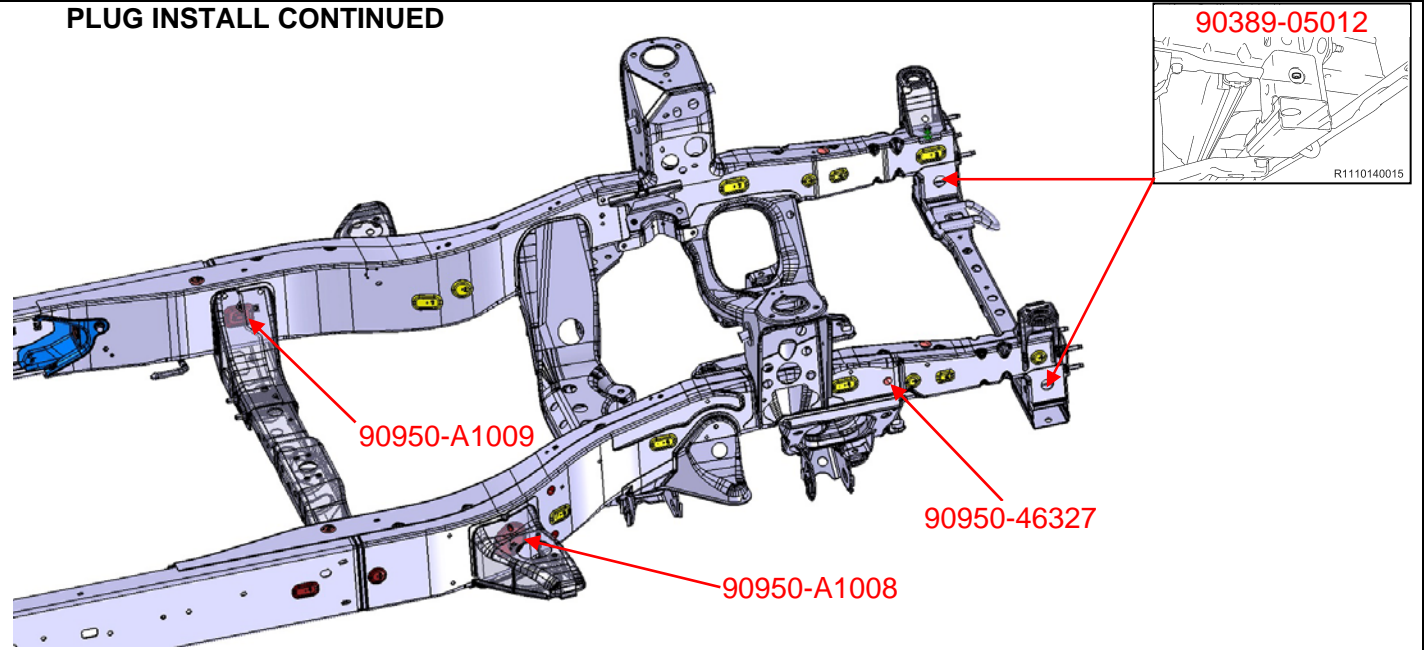

**PLUG INSTALL CONTINUED**



PLUG DIAGRAM/ID	P/N	INSTALLATION INSTRUCTIONS	TOTAL QTY
	<b>90389-05012</b>	This plug is installed by reaching through the 0 crossmember.	<b>2</b>
<b>LARGE CIRCLE PLUG</b>	<b>90950-A1008</b>	Reach through cab mount and install body plug.	<b>2</b>
<b>RECTANGLE PLUG WITH SLOT FOR SCREWDRIVER</b>	<b>90950-A1009</b>	Using a flap tip screw driver install the plug into the side rail through the crossmember.	<b>2</b>
Bolts	<b>90119-A0169</b>	Install bolts into threaded holes in the bottom of the frame rail as shown.	<b>4</b>
	<b>90080-46327</b>	Push to seat installation	
	<b>90950-01A24</b>	Install this plug into the bottom of the frame rail as shown.  It must be installed with the channel opening facing the outer portion of the frame to ensure road spray does not enter the frame.	<b>2</b>

## F. APPLICATION OF NOXUDOL 300S EXTERNAL CRC APPLICATION

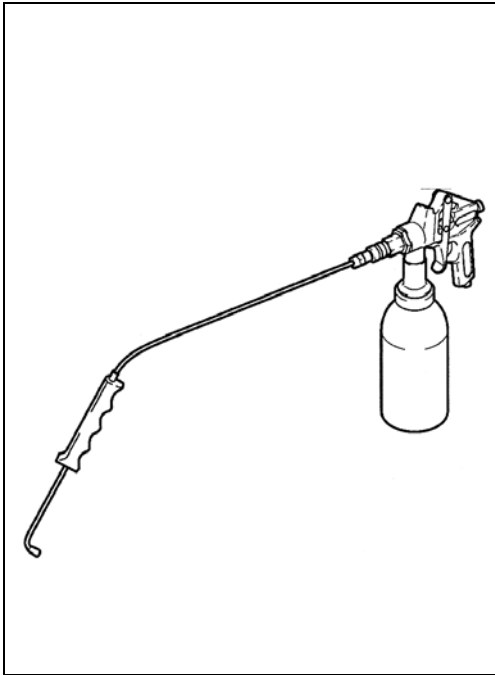

1. LOWER THE VEHICLE
2. SETTING UP THE SPRAY GUN FOR NOXUDOL 300S EXTERNAL FRAME CRC APPLICATION

### Notes:

- Use a dedicated spray gun for the NOXUDOL 300S.
- Make sure to wear protective eyewear, chemical resistant gloves, appropriate NIOSH approved respirator, and refer to the MSDS located in the Appendix when handling and spraying CRC.

- a) Check the temperature of the Noxudol 300S.

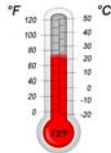

If the Noxudol 300S is below 72° F, place the Noxudol 300S container in a bucket of hot water (<104° F) for 15 minutes and allow it to warm so the proper viscosity is achieved.

- b) Shake the Noxudol 300S container well so that the contents are mixed thoroughly. Settling may occur over time.
- c) Fill the dedicated tank with Noxudol 300S and attach it to the spray gun.
- d) Connect the external spray tube, as shown in the illustration.
- e) Adjust the spray gun nozzle flow/volume.
  1. Turn the adjustment screw to the fully closed position (clockwise).
  2. Then loosen the adjustment screw 3.5 turns.



**Caution: Air regulator is extremely sensitive; always follow instruction to avoid damage to the gun!**

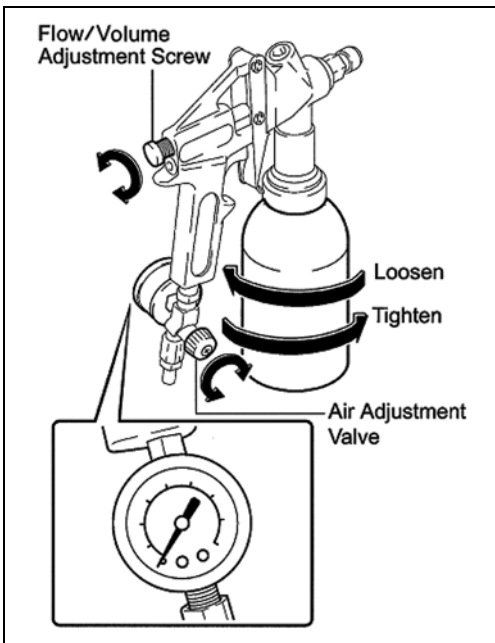

- f) Adjust the air pressure regulator.
  1. Place the nozzle in a clean empty box or pail.
  2. Completely close the air regulator (No Air Flow).
  3. Attach the air hose to the gun
  4. Fully press the spray gun trigger, and slowly adjust the air pressure to 50 psi.

**Note: The air regulator has a slight delay and may take up to 10 seconds before the air pressure stabilizes; Move the adjustment knob in very small increments (1/8 turn).**

5. Recycle the amount sprayed out and use it during the application process.
- g) For Noxudol 300S, it will be necessary to refill the spray gun.
  1. Disconnect the air hose
  2. Loosen the bottle to slowly discharge the pressure through the threads of the bottle.
  3. After all the pressure is discharged, detach the bottle.

### Notes:

- DO NOT remove the bottle until the pressure is released.
- DO NOT pull the spray gun trigger when the air hose is disconnected, this causes CRC to backflow into the air inlet.
- Thoroughly shake the Noxudol 300S liter before use.
- Apply all three liters of Noxudol 300S to the left and right frames and the cross-members. (No product is allowed to remain.)

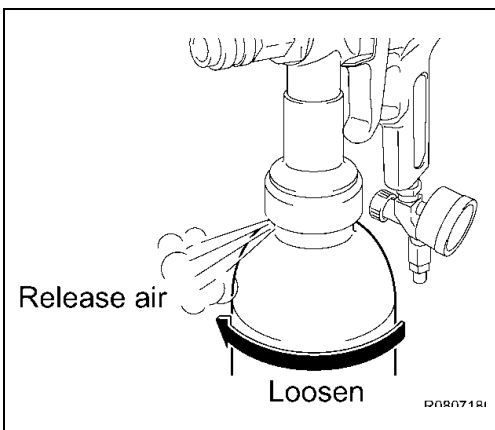



## G. UNDER VEHICLE NOXUDOL 300S CRC APPLICATION

### 1. AFTER REVIEWING THE APPLICATION PROCESS OUTLINED BELOW, BEGIN APPLYING NOXUDOL 300S TO THE EXTERNAL SURFACES OF THE FRAME



- Step① Coat outer and bottom surfaces of right side frame. (Start from front of the vehicle)
- Step② Coat inside surfaces of right side frame. (Start from rear of vehicle)
- Step③ Coat No.0, No.1, No.2, No.3, No.4, No.5, No.6, and rear cross-members from front to back. (Start from front of vehicle)
- Step④ Coat inside surfaces of left side frame. (Start from rear of vehicle)
- Step⑤ Coat outer and bottom surfaces of left side frame. (Start from front of vehicle)

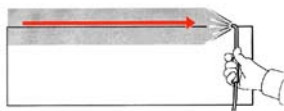
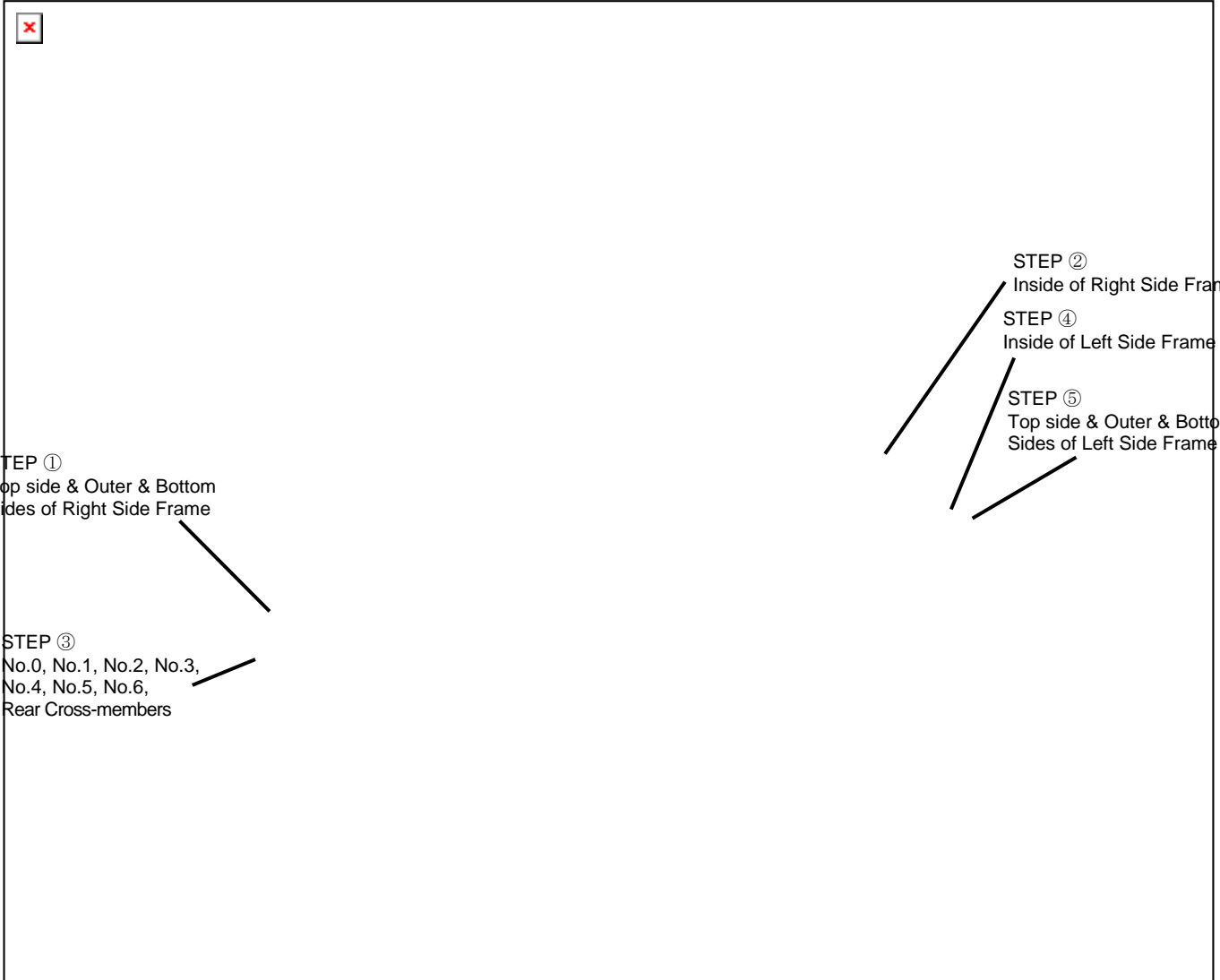

Position the nozzle 10~20 cm (4 to 8 in.) away from the frame surface. Then apply the Noxudol 300 to the outside frame rail moving the wand at a constant speed of 0.15 m/sec (6 in/sec).



Without stopping, move down and reverse direction as shown in the illustration until the section is completed. Slightly overlap each pass by 5.0 cm (2.0 in.) so no gaps appear.

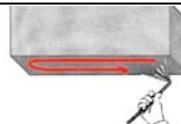

Once the outside surface of the frame rail section you are working on has been completed, without stopping, spray the bottom side as shown in the illustration. Spray the remaining frame and cross-member surfaces in the same manner.

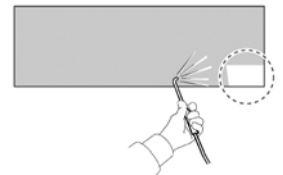

After the entire frame has been completed, inspect and spray any areas that may have been missed.

**Discharge rate varies depending on CRC temperature. Make adjustments to spray rate as needed, but do not change air pressure (air pressure must be 50 psi).**

## H. RESTORE THE VEHICLE

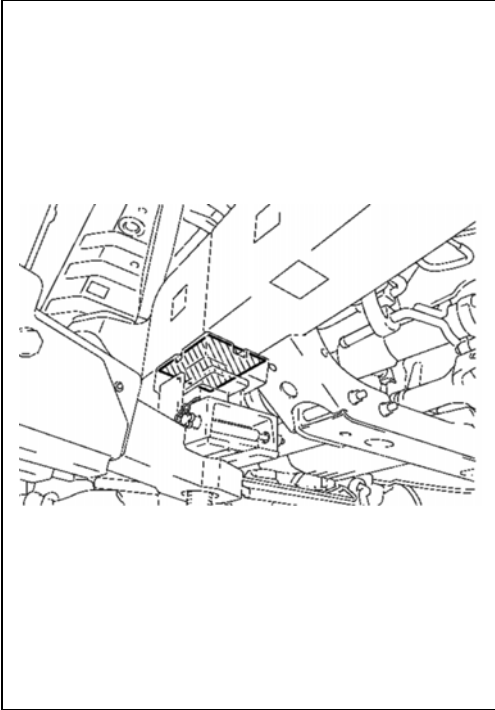

### 1. RESTORE THE VEHICLE

- a) Re-install the engine undercover.
- b) Re-install wheels and torque to spec.

Steel Wheel / Aluminum Wheel

**Torque Spec: 113 N m (1152 kgf cm, 83 ft lbf)**

- c) Lower the vehicle.
- d) For areas where the lift arms touched, remove any rust present and apply Noxudol 300S.



**CONFIRM ALL 3 LITERS OF NOXUDOL 300S HAVE BEEN APPLIED TO THE EXTERNAL PORTION OF THE FRAME!**



**Ensure to follow the procedure and perform all steps completely (e.g. inspection, cleaning/rust removal, CRC application, one kit per vehicle, etc.) any deviation will be subject to warranty claim debit.**

- e) Raise the vehicle.
- f) Remove all masking tape, fire retardant sheeting, and plastic coverings.
- g) Lower the vehicle.
- h) Install the spare tire.
- i) Remove protective tape from the identifying labels (VIN label, etc.) on the frame.
- j) Place a Corrosion-Resistant Compound information Hang Tag on the rear-view mirror.
- k) Let CRC cure approximately 24 hours before returning vehicle to customer.

### **RECORD-KEEPING AND OTHER REQUIREMENTS**

**To make sure that your dealership can satisfy specific state and local requirements, please refer to your specific state Dealer Information Packet.**

## APPENDIX

### A. 712AM & NOXUDOL 300S DISPOSAL

712AM & Noxudol 300S used in the application of the frame CRC as well as any materials, such as tarps with residue, must be disposed of in the same manner as other hazardous waste at your dealership and in accordance with all applicable local, state, and federal regulations. Please refer to the Dealer Information Packet for additional information.

### B. TEMPLATES FOR FRAME SEAL INSTALL

Template A

H10

H9

H8

L20

L21

L22

L23

100

20

33

(10.8)

177.1

80.8

160

100

PUT THIS PORTION WITH SIDE RAIL UPPER.

DATUM HOLE ON SIDE RAIL  
PUT THIS PORTION WITH DATUM HOLE.

PUT THIS PORTION WITH SIDE RAIL LOWER.

DRILL  $\phi 9$   $\phi 9$   $\sim 10$  HOLE ON SIDE RAIL

LH

PAPER PATTERN

A3-SIZE

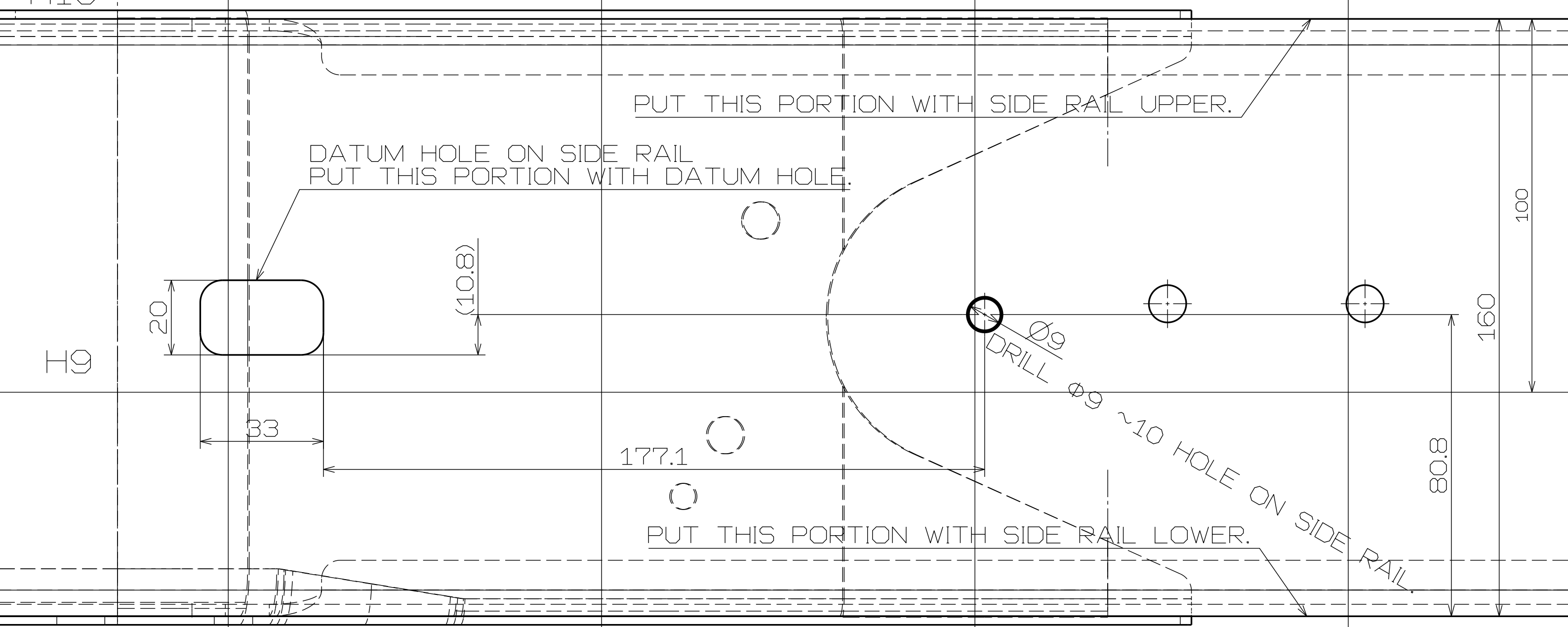

Template B

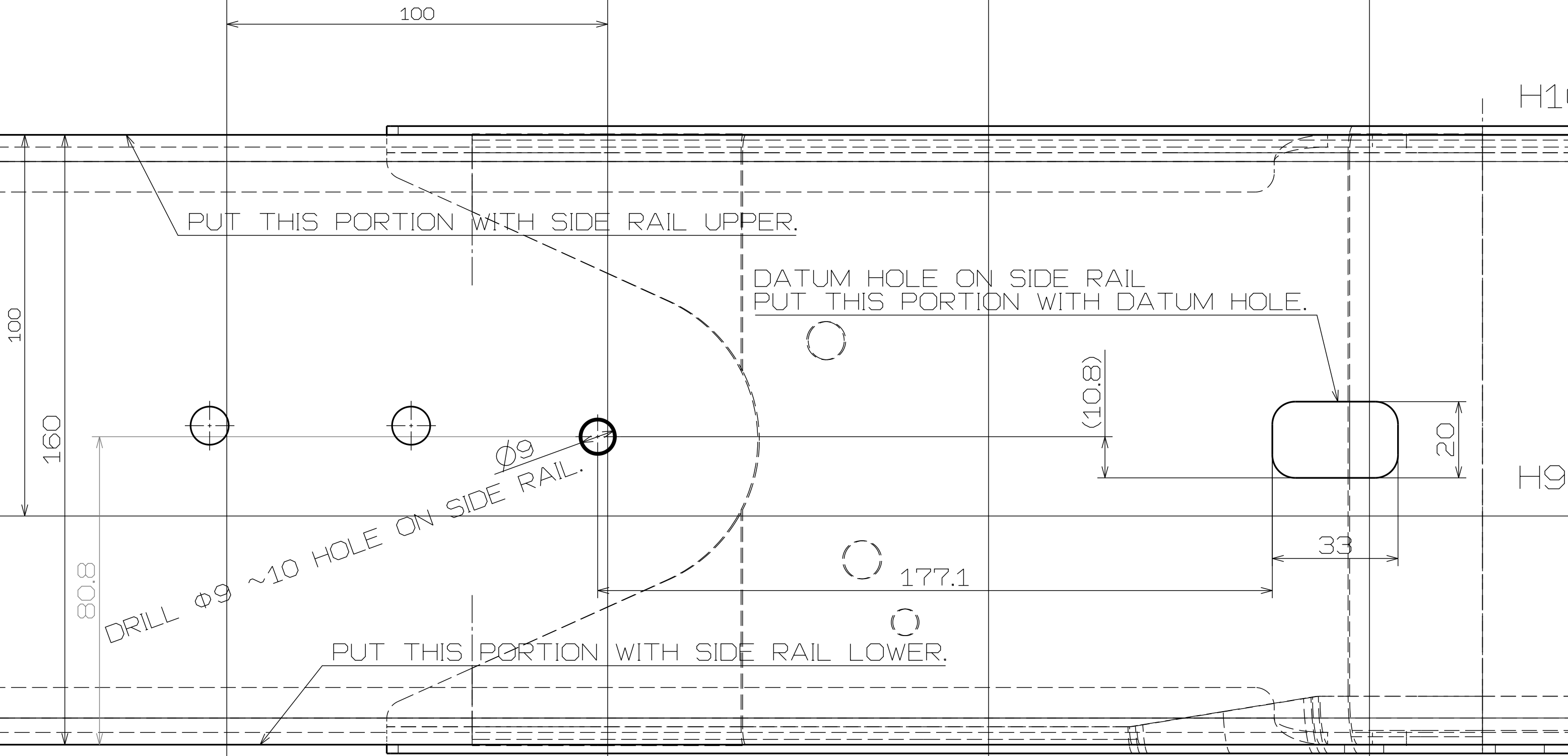

RH  
PAPER PATTERN

H8

A3-SIZE

L23

L22

L21

L20

# Template C

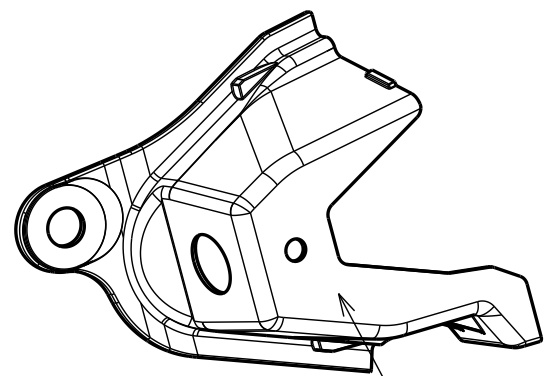
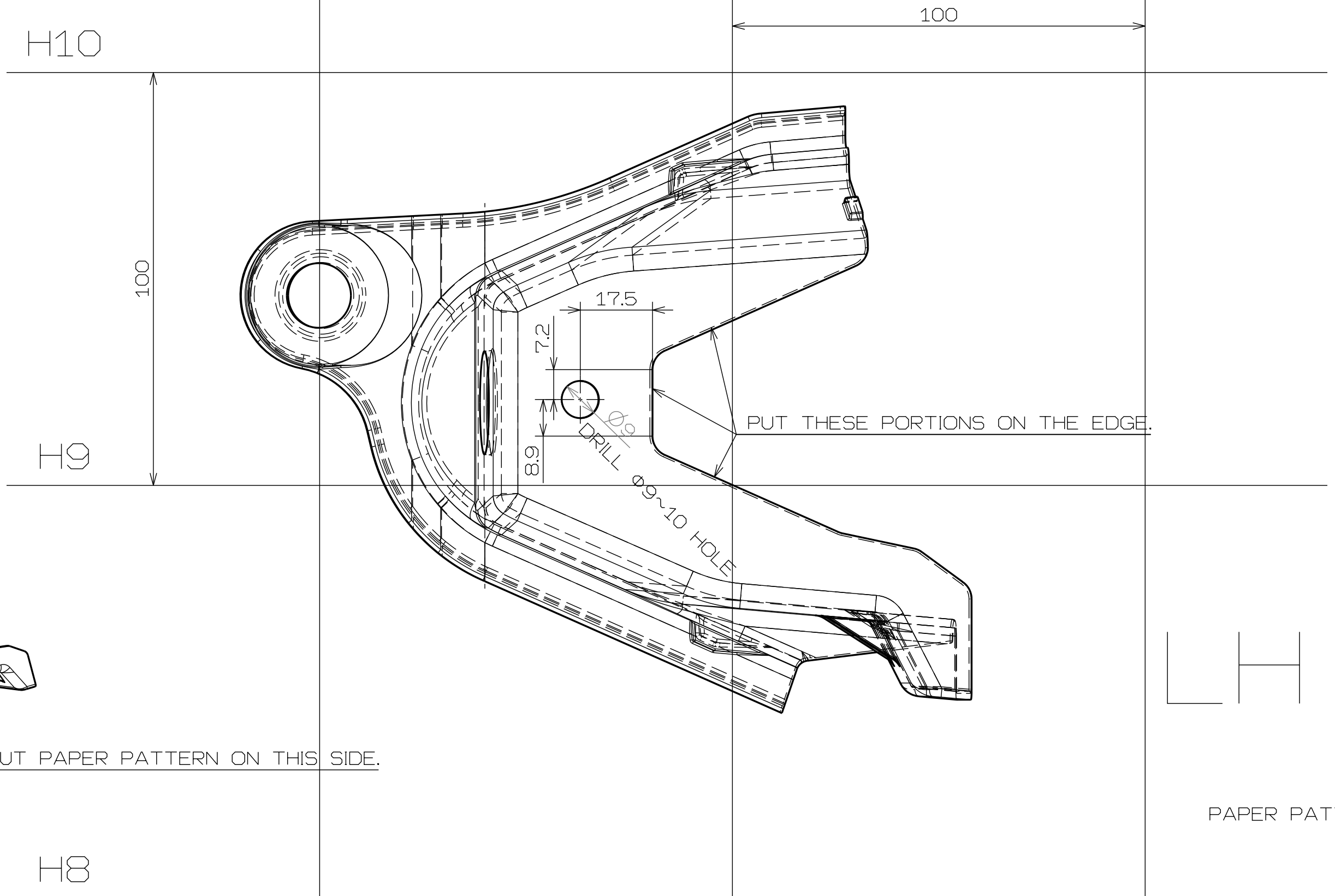

PUT PAPER PATTERN ON THIS SIDE.

PUT THESE PORTIONS ON THE EDGE.

LH

PAPER PATTERN

H8

A3-size

# Template D

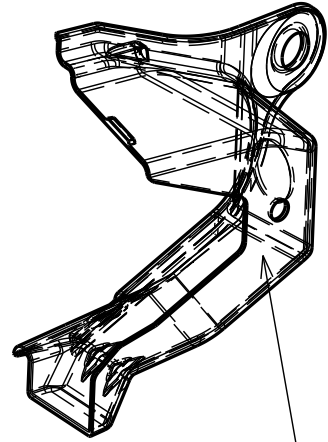

PUT PAPER PATTERN ON THIS SIDE.

PUT THESE PORTIONS ON THE EDGE.

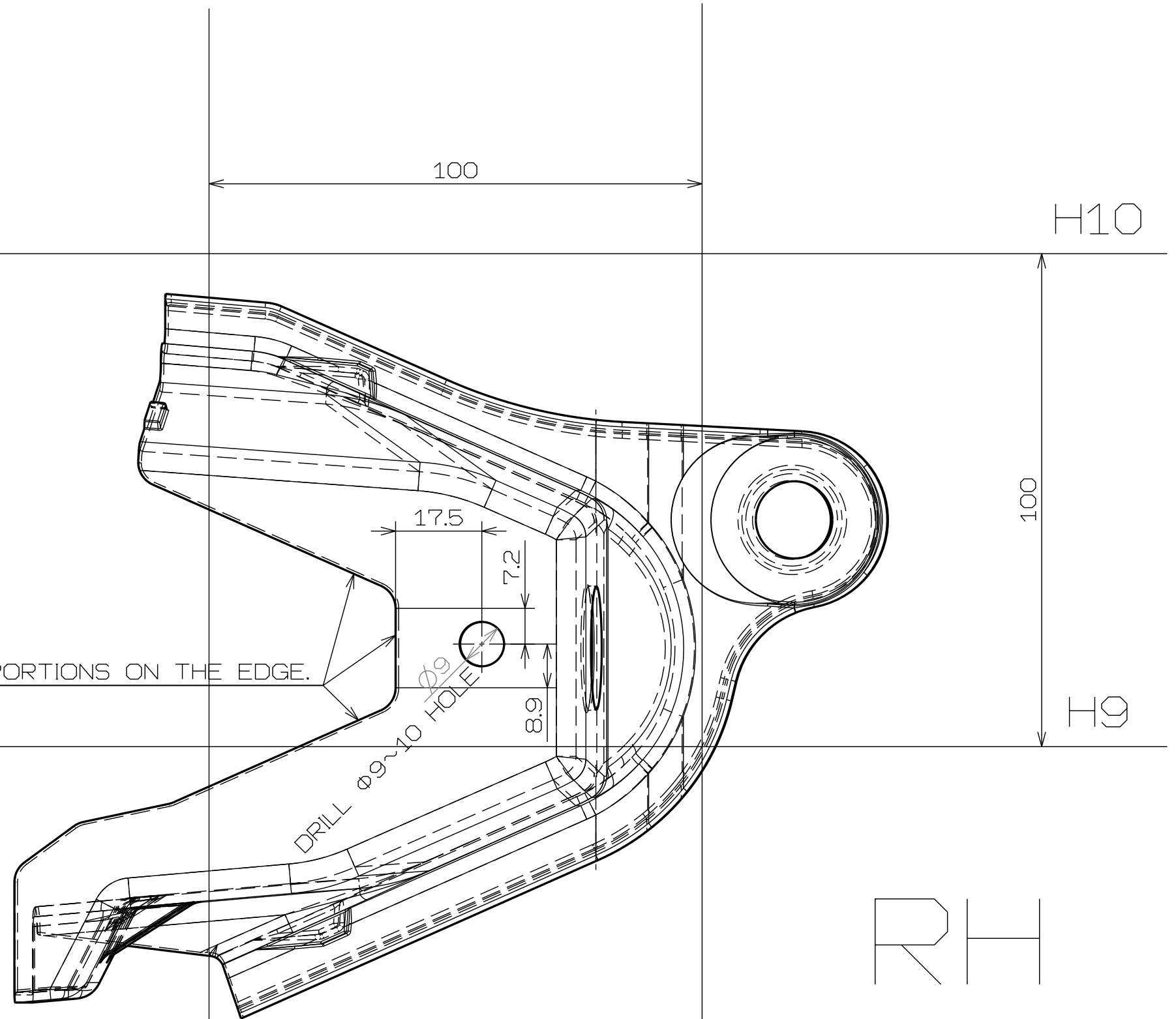

RH

PAPER PATTERN

H8

A3-size