



---

Jason Guidi

---

Director - Regulatory & Compliance

---

June 08, 2017  
Subject: Recall R89716  
TO: All U.S. and Canadian Volvo Retailers

**VEHICLES in RETAILER INVENTORY**

**It is a violation of federal law for a retailer to deliver any new Volvo that is eligible for a recall. Retailers are advised to check all vehicles in inventory for recall eligibility and repair immediately. Violation of this requirement by a retailer could result in a civil penalty of up to \$21,000 per vehicle.  
Correct all vehicles in your new vehicle inventory before delivery.**

Volvo Car USA LLC and Volvo Car Canada LTD (Volvo) on behalf of Volvo Car Group has decided to launch Recall R89716 on certain model year 2017 XC90 vehicles.

The crimping of the tube for the Micro Gas Generator (MGG) in the 3<sup>rd</sup> row passengers side seat belt retractor, was not manufactured to specification. In the event of a crash where the pre-tensioner is activated and in combination with certain conditions, the MGG squib may detach and be propelled out of the tube. If the MGG squib penetrates the inner side trim panel, it will lose most of its kinetic energy before it may enter the 3<sup>rd</sup> row occupant compartment. Despite this condition, the seat belt functions properly.

The corrective action is to replace the 3<sup>rd</sup> row passenger's side seatbelt retractor.

A total of 1,305 U.S. and 101 Canadian vehicles are eligible for this recall.

Vehicle eligibility must be confirmed:

- Vehicle Inquiry – Vehicle Warranty where the message "Recall R89716 Replace 3<sup>rd</sup> Row Seatbelt Retractor" will appear for eligible vehicles.
- All cars not yet delivered to end customers must be corrected prior to delivery.



- There have been no reports of incidents related to this issue.
- If you have any questions concerning this recall send them to [recall@volvocars.com](mailto:recall@volvocars.com).

### **OWNER NOTIFICATION**

Owner notification letters will be mailed in August. Owners of eligible retailed vehicles that are requesting this recall to be performed should be accommodated.

### **PORT VEHICLES**

No vehicles will be shipped from the ports with this recall not completed.

### **PARTS / PARTS RETURN**

No replacement parts are available at this time. We will be updating this communication and the Parts Bulletin as parts shipment information becomes available.

### **CLAIM SUBMISSION**

Please refer to the claim submission information in the attached Quality Bulletin.

### **RETAILER RESPONSIBILITIES**

Retailers must perform this recall campaign on eligible vehicles regardless of miles/kilometers or vehicle age. All work performed under this recall is free of charge to the owner.

As the safety of our customers is our utmost priority, we are taking full responsibility to ensure the highest quality and safety standards for our cars.

If you have questions about this recall or any other field service action, please contact me or any member of the Product Safety and Compliance office.

Your cooperation in completing this important recall is greatly appreciated.

Drive Safely,

A handwritten signature in black ink that reads "Jason Guidi".

Jason Guidi

Director - Regulatory & Compliance

201-768-7300

[jason.guidi@volvocars.com](mailto:jason.guidi@volvocars.com)

VOLVO CAR SERVICE AND PARTS BUSINESS				
<h1>Quality Bulletin</h1>				
TITLE: <b>Recall R89716: Replace 3rd Row Passengers Side Seatbelt Retractor Model Year 2017, Model XC90 with 7 Seats</b>				
GROUP:	CAT/NO: R89716	ISSUING DEPARTMENT: Warranty		CAR MARKET: United States and Canada
REFERENCE BULLETINS: TJ 32813			ISSUE DATE: 2017-06-08	STATUS DATE: 2017-06-08
Service Personnel: Read and initial	SERVICE MANAGER	SERVICE WRITER	WARRANTY ADMINISTRATOR	
			Page 1 of 3	

**“Right first time in Time”**

- A. RECALL R89716 DESCRIPTION
- B. VEHICLES INVOLVED
- C. PARTS INFORMATION/PARTS RETURN
- D. OWNER NOTIFICATION
- E. VEHICLES IN RETAILER INVENTORY
- F. RETAILER RESPONSIBILITY
- G. CAMPAIGN REIMBURSEMENT PROCEDURES
- H. TECHNICIAN COMPETENCY REQUIREMENT
- I. RETAILER ALLOWANCE

**A. RECALL R89716 DESCRIPTION**

Volvo Car USA LLC and Volvo Car Canada LTD (Volvo) on behalf of Volvo Car Group has decided to launch Recall R89716 on certain model year 2017 XC90 vehicles with 7 seats.

The crimping of the tube for the Micro Gas Generator (MGG) in the 3rd row passengers side seat belt retractor, was not manufactured to specification. In the event of a crash where the pretensioner is activated and in combination with certain conditions, the MGG squib may detach and be propelled out of the tube. If the MGG squib penetrates the inner side trim panel, it will lose most of its kinetic energy before it may enter the 3rd row occupant compartment.

Despite this condition, the seat belt functions properly.

The corrective action is to replace the 3rd row passenger’s side seatbelt retractor.

A total of 1,305 U.S. and 101 Canadian vehicles are eligible for this recall.



## **B. VEHICLES INVOLVED**

**NOTE: RETAILER MUST CONFIRM VEHICLE ELIGIBILITY PRIOR TO BEGINNING THE REPAIR FOR THIS RECALL.**

Vehicle eligibility must be confirmed:

- Vehicle Inquiry – Vehicle Warranty where the message “Recall R89716 Replace 3rd Row Seatbelt Retractor” will appear for eligible vehicles or check eligibility in TIE.

All vehicles should be checked for any incomplete recalls or service campaigns or service upgrades. All open Recall, Service Campaign or Service Action repairs should be completed. If you have any questions concerning this recall send them to [recall@volvocars.com](mailto:recall@volvocars.com).

## **C. PARTS / PARTS RETURN**

No replacement parts are available at this time.

Please refer to Parts Bulletin 88-R89716 for updates.

Replaced parts are required to be returned to Technical Material Analysis for this recall.

### **PORT VEHICLES**

No vehicles will be delivered from the ports without having this recall performed.

All vehicles must be checked for any incomplete recalls or service campaigns or service upgrades prior to delivery.

## **D. OWNER NOTIFICATION**

Owner notification letters will be mailed in August. Owners of eligible retailed vehicles that are requesting this recall to be performed should be accommodated.

## **E. VEHICLES IN RETAILER INVENTORY**

It is a violation of federal law for a retailer to deliver any new Volvo that is eligible for a recall. Retailers are advised to check all vehicles in inventory for recall eligibility and repair immediately. Violation of this requirement by a retailer could result in a civil penalty of up to \$21,000 per vehicle. Correct all vehicles in your new vehicle inventory before delivery.

## **F. RETAILER RESPONSIBILITY**

All vehicles qualifying for this recall must be repaired prior to a customer taking possession of the vehicle.

## **G. CAMPAIGN REIMBURSEMENT PROCEDURES**

Recall R89716 claims should be submitted using the LONG FORM application only.

## **H. TECHNICIAN COMPETENCY REQUIREMENT**

The technician competency requirement for this campaign repair is: Level 2 – Certified Tech.



# Quality Bulletin R89716

## I. RETAILER ALLOWANCE (LONG FORM APPLICATION)

**Claim Type:** R89716  
**Cause Code:** 02  
**CSC Code:** XW  
**Main OP:** 97195  
**Failed Part:** 39825742, 39842894

<u>Operation Number</u>	<u>Repair Description</u>	<u>Qty</u>	<u>Labor Time</u>
97195	Replace 3rd Row Seatbelt Retractor	1	0.6 Hr



# Technical Journal

TITLE:

**Recall R89716: Replace 3rd Row Passengers Side Seatbelt Retractor**

<b>REF NO:</b> TJ 32813.1.2	<b>ISSUING DEPARTMENT:</b> Technical Service	<b>CAR MARKET:</b> United States and Canada	
<b>PARTNER:</b> 3 US 7510 Volvo Car USA		<b>ISSUE DATE:</b> 2017-09-19	<b>STATUS DATE:</b> 2017-09-26
<b>FUNC GROUP:</b> 8800	<b>FUNC DESC:</b> Interior equipment	Page 1 of 11	

“Right first time in Time”

## Attachment

File Name	File Size
QBI-504457-1_1_1_en-US.pdf	3.6166 MB

## Vehicle Type

Type	Eng	Eng Desc	Sales	Body	Gear	Steer	Model Year	Plant	Chassis range	Struc Week Range
256							2017-2017		-	0-0

## CSC Customer Symptom Codes

Code	Description
XW	Service/repair/Service action/Recall

## VST Operation Number

VST Operation Number	Description
97195	Replace 3rd Row Passenger Side Seatbelt Retractor

## DTC Diagnostic Trouble Codes

Rows beginning with \* are modified

Note! If using a printed copy of this Technical Journal, first check for the latest online version.

## Text

**DESCRIPTION:**

Volvo Car USA LLC and Volvo Car Canada LTD (Volvo) on behalf of Volvo Car Group has decided to launch Recall R89716 on certain model year 2017 XC90 vehicles with 7 seats.

The crimping of the tube for the Micro Gas Generator (MGG) in the 3rd row passengers side seat belt retractor, was not manufactured to specification. In the event of a crash where the pre-tensioner is activated and in combination with certain conditions, the MGG squib may detach and be propelled out of the tube. If the MGG squib penetrates the inner side trim panel, it will lose most of its kinetic energy before it may enter the 3rd row occupant compartment.

Despite this condition, the seat belt functions properly.

**SERVICE:**

The corrective action is to replace the 3rd row passenger's side seatbelt retractor.

**VEHICLE REPORT:**

N/A

**To view TJ attachment continue to next page. This TJ has one attachment.**



## Volvo Car Customer Service

QB Instruction VCC-504457-1

<b>Title</b>	Seat belt retractor, rear	<b>Page</b>	1 ( 9 )
<b>Action</b>	Replacement	<b>Operation number:</b>	97195-2

Issue	Date	Reason
1	2017-05	First issue

### Affected vehicles

Model year	Model
2017	XC90 (16-)

### Materials

Materials	Qty.	Part No.	Notes
Seat belt	1.0	39825742	3:D Row, Charcoal, US/CDN, RH;
Seat belt	1.0	39842894	3:D Row, Blond, US/CDN, RH;

### Special tools

Description	Part No.
Interior trim remover	981 4071



Orientation view

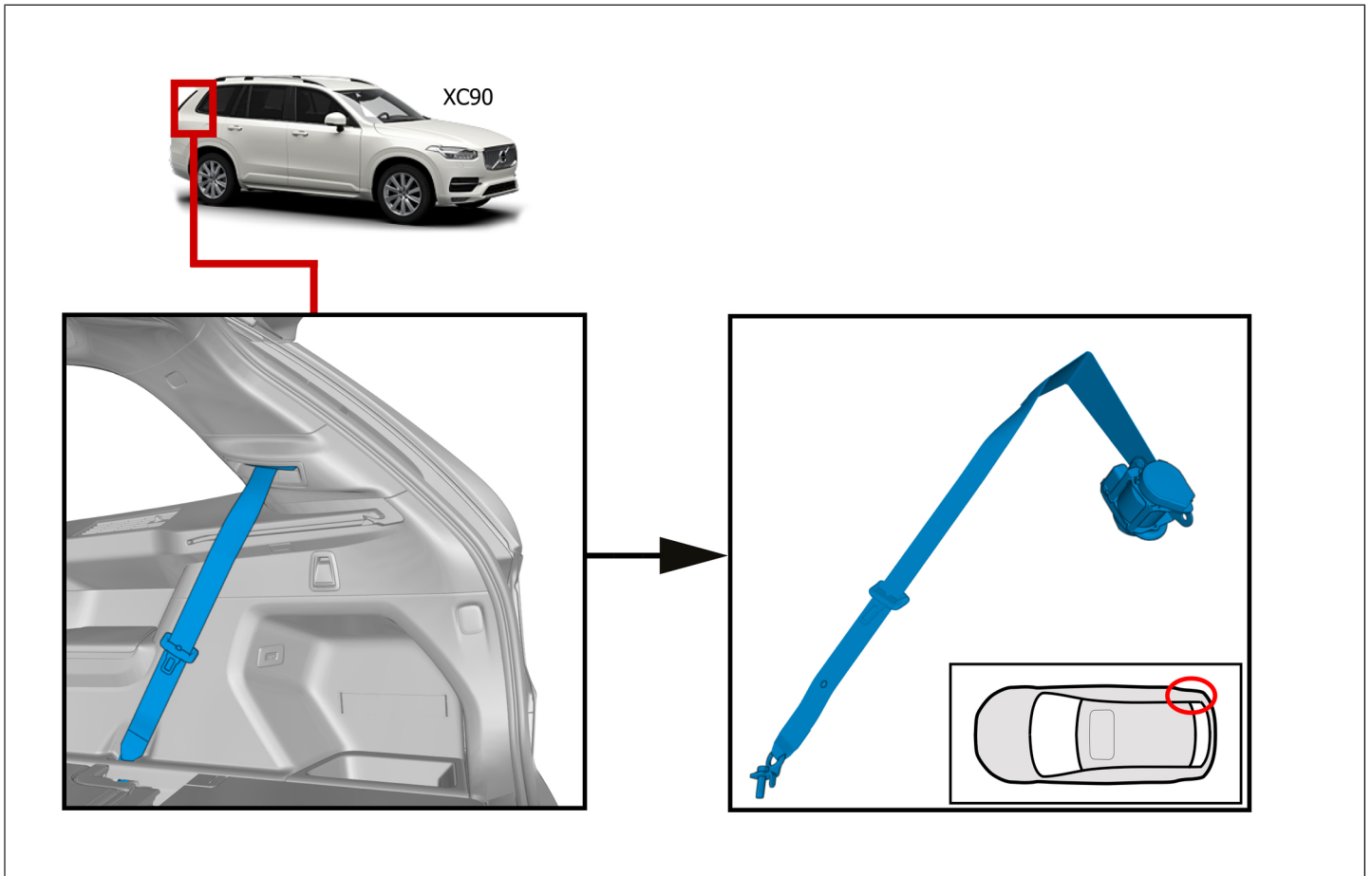

Color symbols

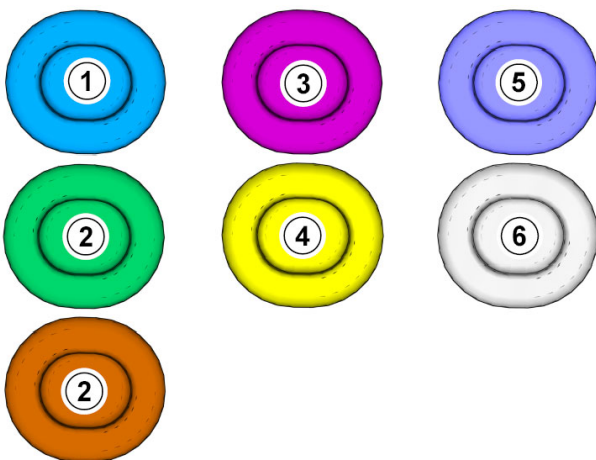

**Note! This colour chart displays (in colour print and electronic version) the importance of the different colours used in the images of the method steps.**

- 1 . Used for focused component, the component with which you will do something.
- 2 . Used as extra colors when you need to show or differentiate additional parts.
- 3 . Used for attachments that are to be removed/installed. May be screws, clips, connectors, etc.
- 4 . Used when the component is not fully removed from the vehicle but only hung to the side.
- 5 . Used for standard tools and special tools.
- 6 . Used as background color for vehicle components.

**Removal**

**Note:** Although some of the below images for interior panel removal show the left side of the vehicle, this action applies to the right side of the vehicle only.

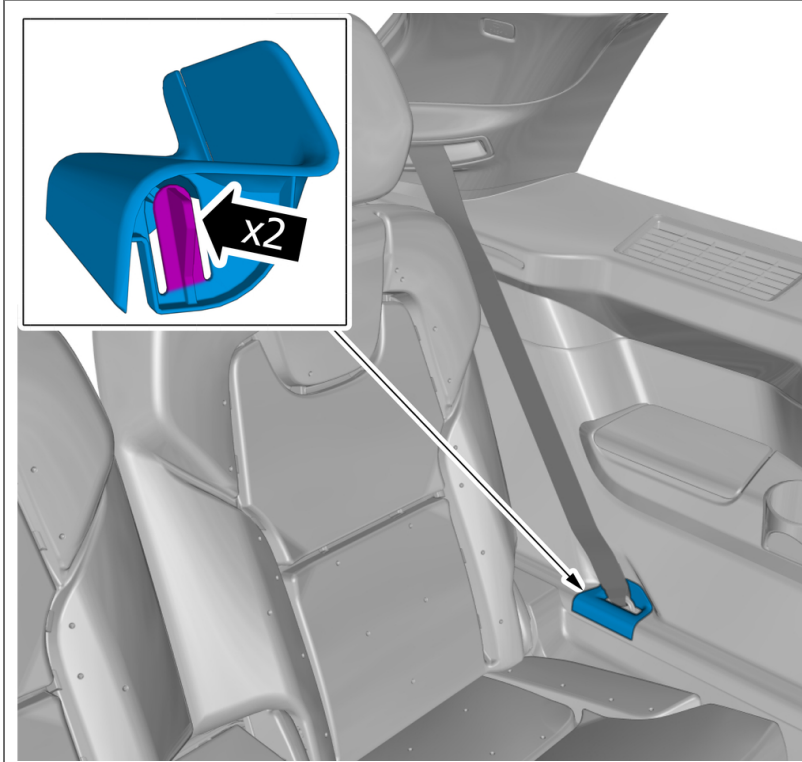

Right-hand side

Remove the marked part.

Special Tool: T9814071, Interior trim remover

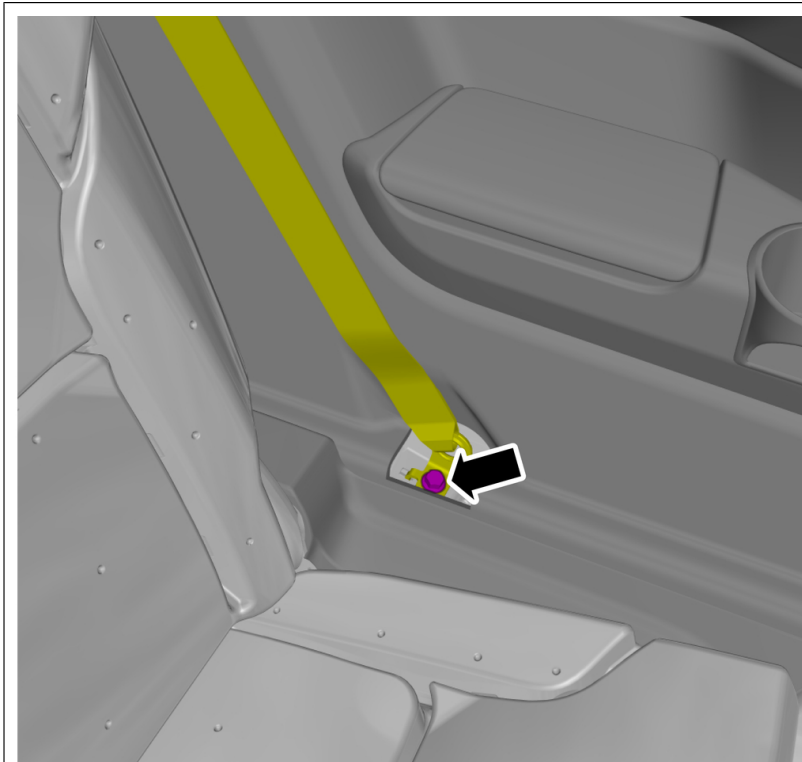

Right-hand side

Remove the screw.

**Torque:**

Safety belt lower anchor to body (rear) ,  
40 Nm

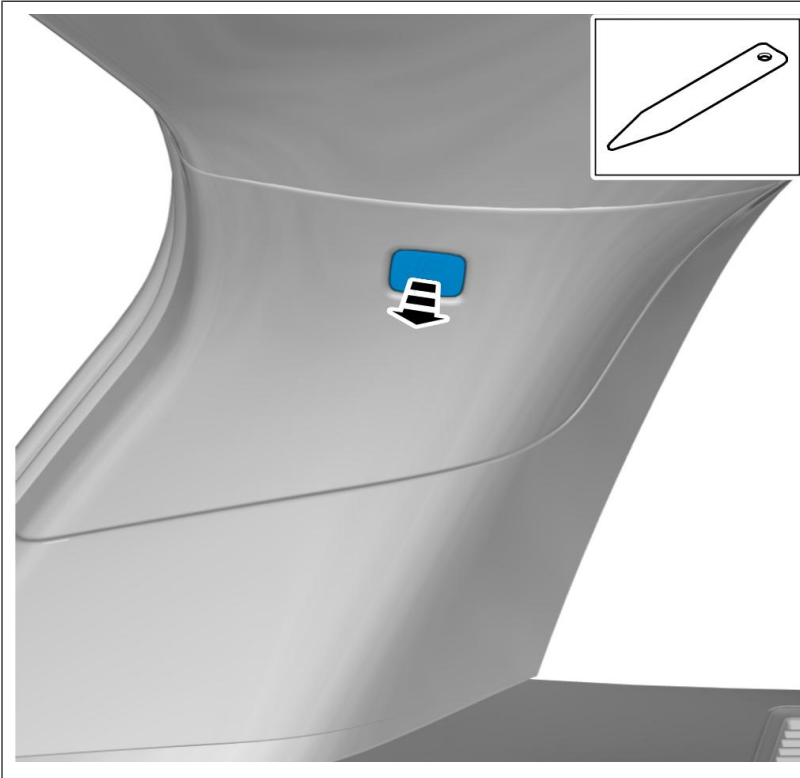

Right-hand side  
Remove the marked part.  
Special Tool: T9814071, Interior trim remover

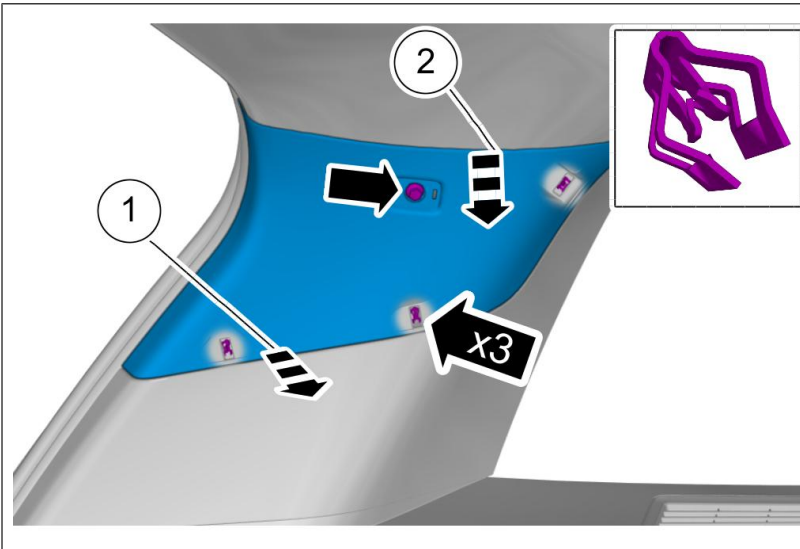

Right-hand side  
1 . **Torque:**  
Panel, to D-Pillar , 4.5 Nm  
2 . Remove the screw.  
3 . Remove the panel.

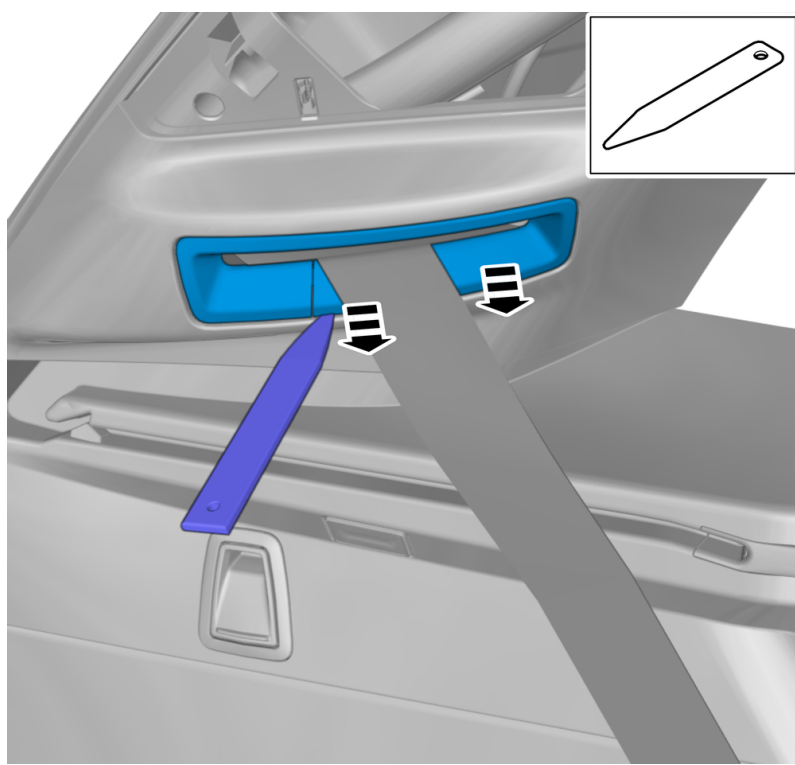

Right-hand side  
Remove the marked part.  
Special Tool: T9814071, Interior trim remover

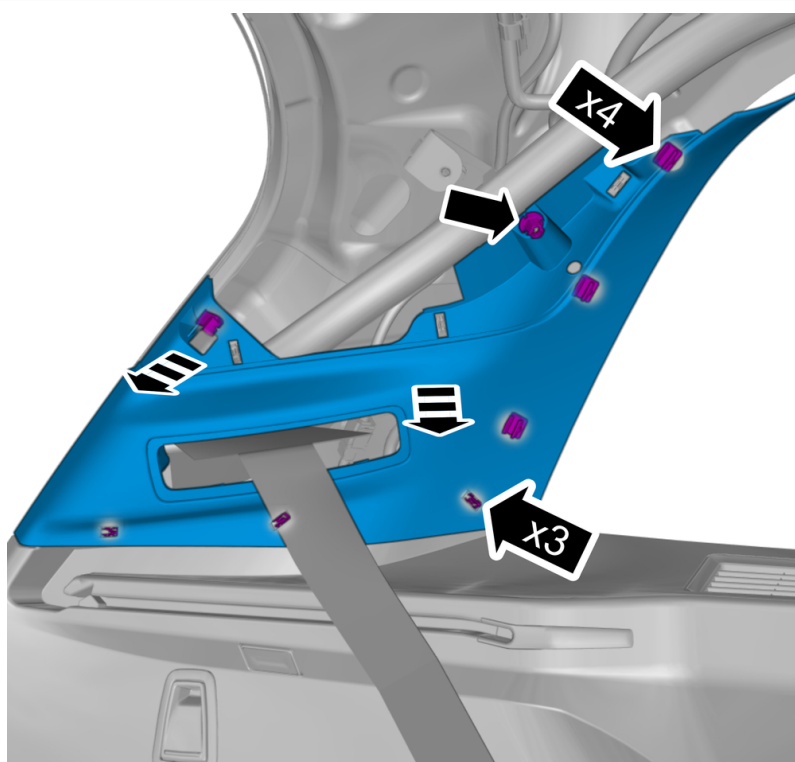

Right-hand side  
Remove the nut.  
Remove the marked part.

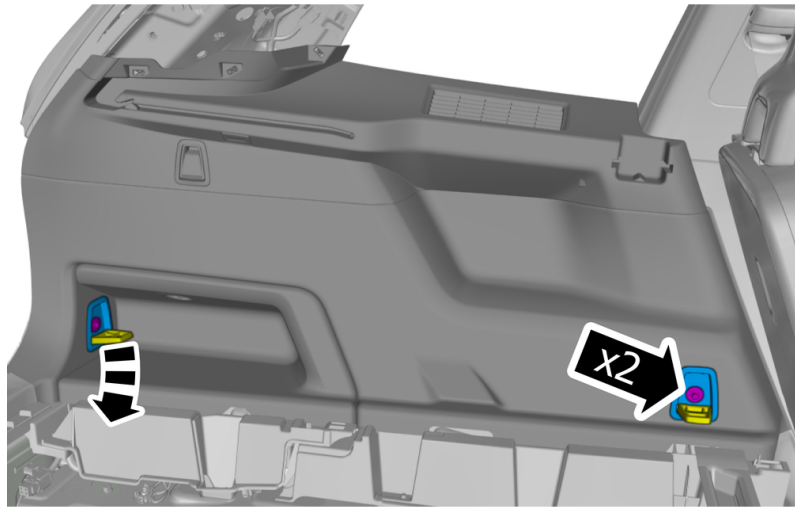

Right-hand side  
Remove the screws.

**Torque:**

Cargo anchor, to body , 13 Nm

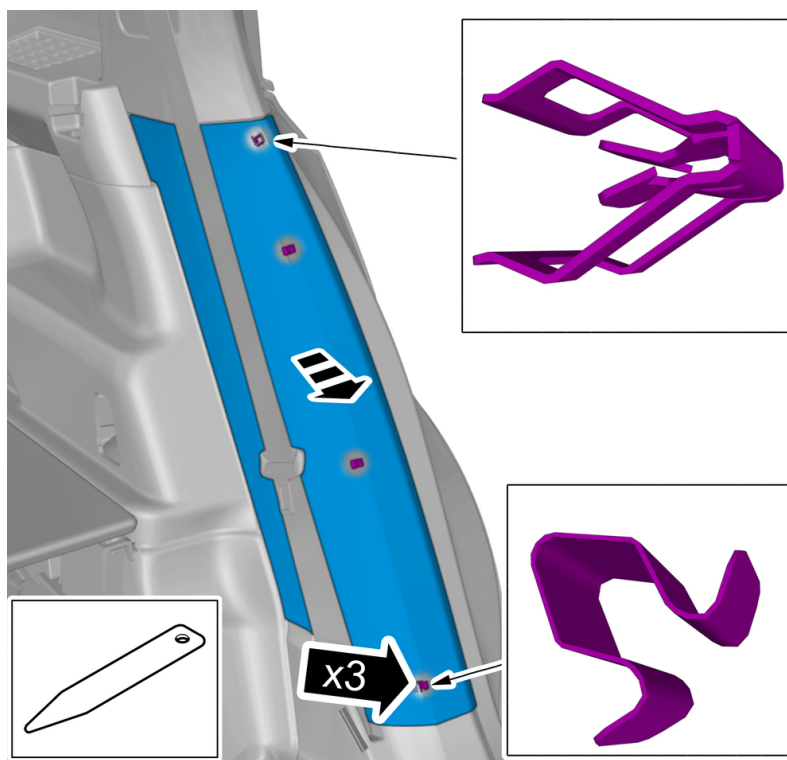

Right-hand side  
Remove the panel.

Special Tool: T9814071, Interior trim remover

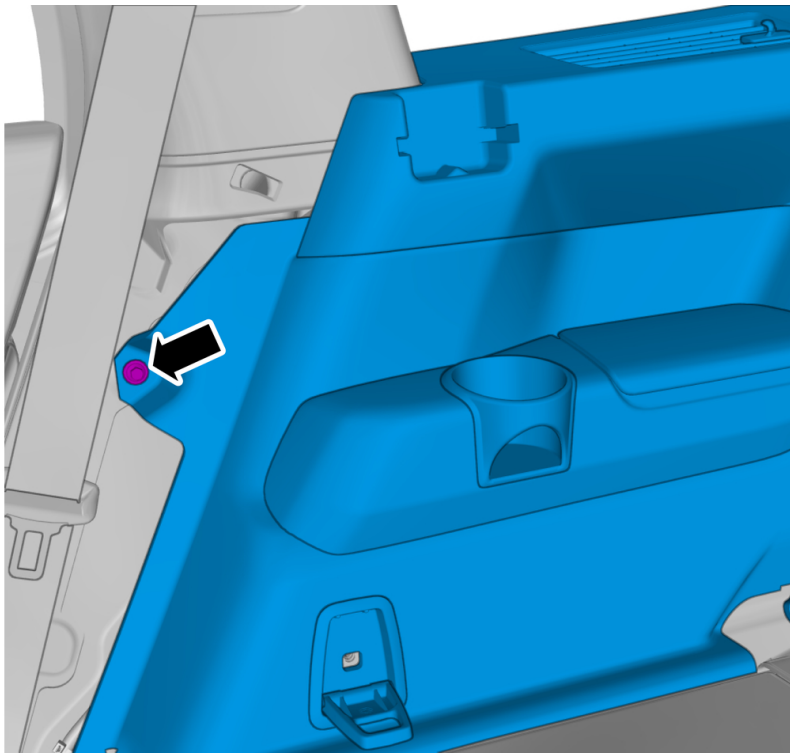

Right-hand side  
Remove the screw.

**Torque:**  
M5 , 5 Nm

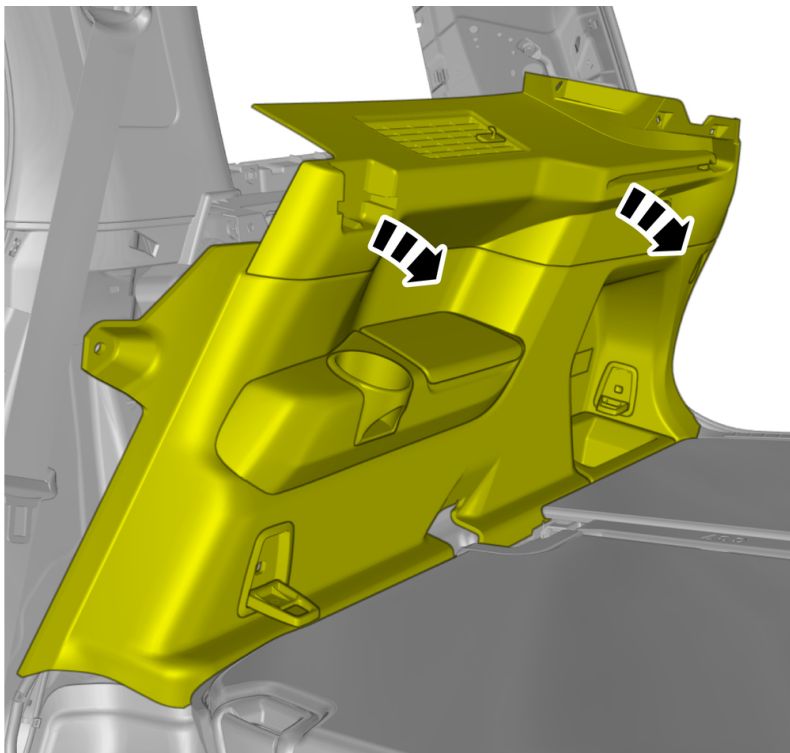

Right-hand side  
Fold marked part to one side.

Disconnect connector ignition cable , refer to:  
3 - Electrical system  
37 - Cables and fuses  
371 - cables

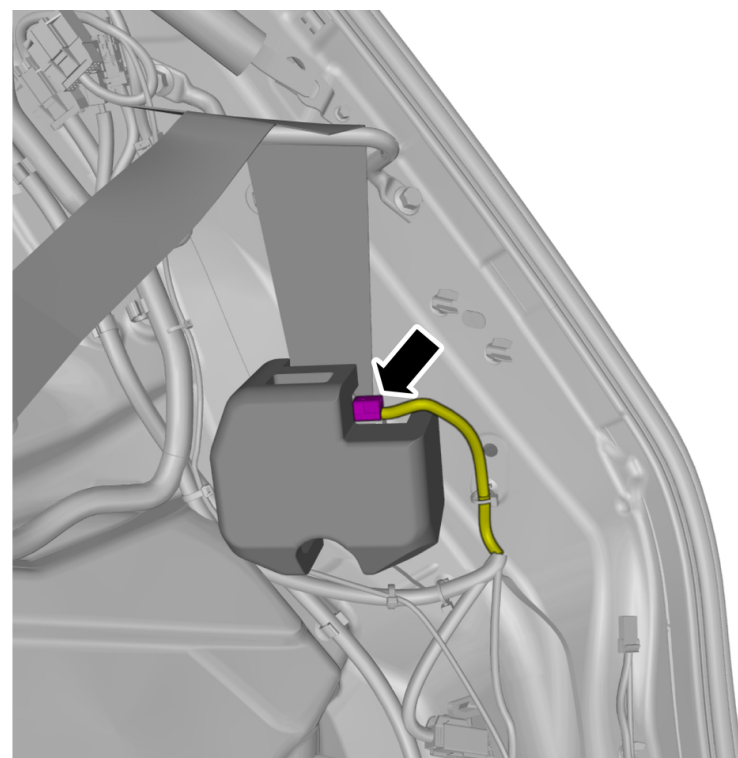

Right-hand side  
Disconnect the connector.

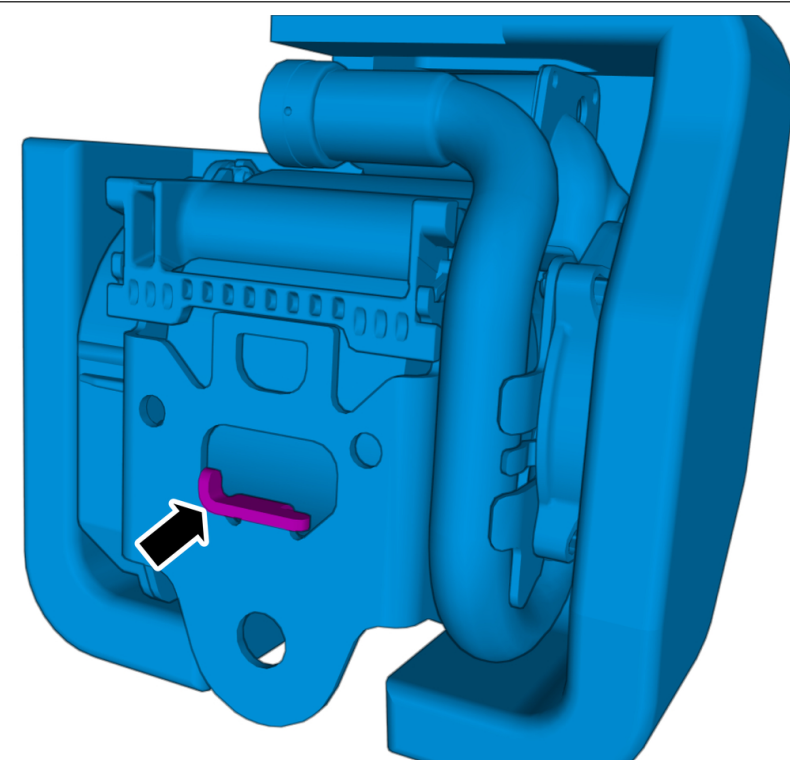

**Note!** The graphic shows the back of the component before removal.

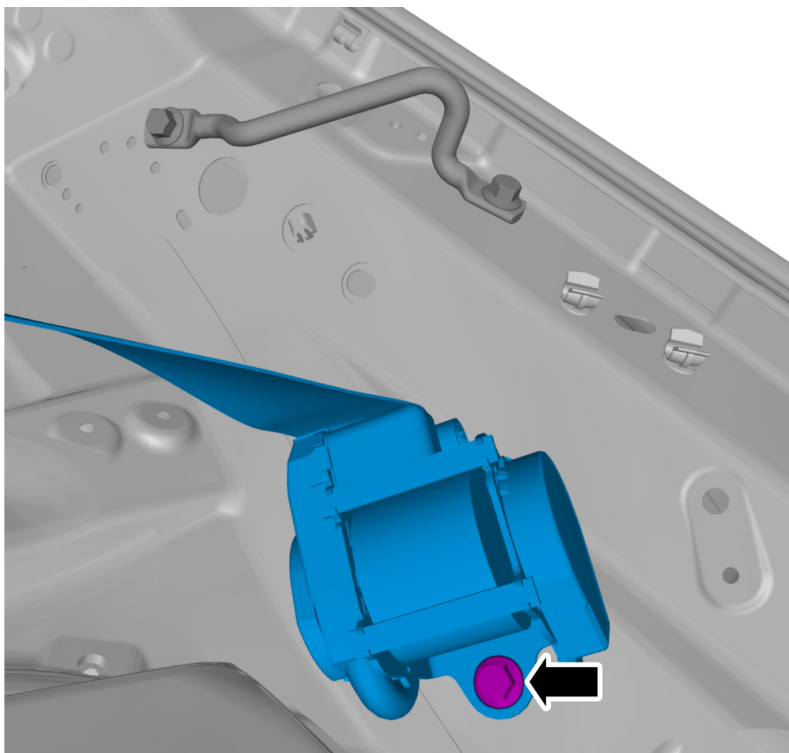

Right-hand side  
Remove the screw.  
Remove the marked part.

**Torque:**

Safety belt retractor rear to body , 40 Nm

**Installation**

To install, reverse the removal procedure.

Check that no diagnostic trouble codes (DTCs) are stored.





# Parts Bulletin

TITLE:

**Recall R89716: Replace 3rd Row Passenger Side Seatbelt Retractor  
Model Year 2017, XC90 with 7 Seats**

<b>GROUP:</b> 8	<b>CAT/NO:</b> R89716	<b>REFERENCE BULLETINS:</b> TJ 32813, QB R89716	<b>CAR MARKET:</b> United States and Canada	
<b>COPY TO / CIRCULATIONS (PLEASE INITIAL):</b>			<b>ISSUE DATE:</b> 2017-06-22	<b>STATUS DATE:</b> 2017-06-22
<b>GENERAL MANAGER</b>	<b>PARTS MANAGER</b>	<b>SERVICE MANAGER</b>	<b>SALES MANAGER</b>	
				<b>Page 1 of 1</b>

**“Right first time in Time”**

**Reference Bulletins: TJ 32813, QB R89716**

Volvo Car USA LLC and Volvo Car Canada LTD (Volvo) on behalf of Volvo Car Group has decided to launch Recall R89716 on certain model year 2017 XC90 vehicles with 7 seats.

The crimping of the tube for the Micro Gas Generator (MGG) in the 3rd row passengers side seat belt retractor, was not manufactured to specification. In the event of a crash where the pre-tensioner is activated and in combination with certain conditions, the MGG squib may detach and be propelled out of the tube. If the MGG squib penetrates the inner side trim panel, it will lose most of its kinetic energy before it may enter the 3rd row occupant compartment. Despite this condition, the seat belt functions properly.

The corrective action is to replace the 3rd row passenger’s side seatbelt retractor.

A total of 1,305 U.S. and 101 Canadian vehicles are eligible for this recall.

The following part numbers apply:

<b>Part Number</b>	<b>Description</b>	<b>Qty</b>
39842894	3rd Row seatbelt retractor (blond)	1
39825742	3rd Row seatbelt retractor (charcoal)	1

**Replacement parts are now available. Parts are not returnable. Please order on an as-needed basis.**



# SAFETY RECALL NOTICE

VOLVO CAR USA LLC  
PO Box 3757, Highland Park, MI 48203-9984

PRESORT  
FIRST-CLASS  
U.S. POSTAGE  
PAID  
VOLVO CAR



**YV4A22PKXH777777**-R89716A666666 521068-01 1

Volvo Owner  
12345 Main St.  
Any City, US 12345-6789



## IMPORTANT SAFETY RECALL INFORMATION



Issued in Accordance  
With Federal Law



August 4, 2017

**NHTSA RECALL 17V370**

### IMPORTANT SAFETY RECALL

**THIS NOTICE APPLIES TO YOUR VEHICLE, VIN: YV4A22PKXH777777**

Dear Volvo Owner,

This notice is sent to you in accordance with the requirements of the National Traffic and Motor Vehicle Safety Act.

Volvo Car USA LLC (Volvo) on behalf of Volvo Car Group, has decided that a defect which relates to motor vehicle safety exists in certain model year 2017 XC90 vehicles.

#### The reason for Recall R89716:

The Micro Gas Generator (MGG), a subcomponent part used within the right hand side seat belt retractor for the third row seats, may detach after the seatbelt retractor pretensioner is deployed. Although, the seat belt will operate as intended in the event of a crash, if the MGG detaches, it may be a projectile within the vehicle cabin, increasing the risk of injury.

The corrective action is to replace the 3rd row passenger's side seatbelt retractor **performed at no cost.**

#### What you need to do:

Please contact your authorized Volvo retailer for an appointment. The repair procedure will be **performed at no cost** and can take up to 1.0 hour to complete. **However, the time your Volvo retailer requires to service your vehicle may be slightly longer depending on the vehicle.**

If you had previously paid for this repair to be performed, prior to receiving this letter, you may be eligible to receive reimbursement for the cost of obtaining a pre-notification remedy of the problem associated with this recall. For more information, please refer to the Volvo Customer Care Center contact information in this letter.

If you no longer own the vehicle described in this letter, please help us to update our records by sending us the updated owner information. Please refer to our contact information below.

***Please contact:***

If you have any questions, please contact your Volvo retailer. If your retailer is unable to answer your questions, please contact Volvo Customer Care Center:

1 Volvo Drive,  
P.O. Box 914,  
Rockleigh, NJ 07647

Or by phone at 1-800-458-1552, Monday through Friday, 8:30 A.M. to 5:00 P.M. ET. You may also contact us by going to <http://volvo.custhelp.com/>.

We have advised the National Highway Traffic Safety Administration (NHTSA) that we are conducting this recall. If you are unable to have this procedure performed without charge, and within a reasonable period of time, you may contact the NHTSA Administrator at:

National Highway Traffic Safety Administration  
1200 New Jersey Avenue, SE.  
Washington, DC 20590

Or you can call the toll-free Vehicle Safety Hotline at 1-888-327-4236 (TTY: 1-800-424-9153). You may also go to their website, <http://www.safercar.gov>.

Federal law requires that any vehicle lessor receiving this recall notice must forward a copy of this notice to the lessee within ten days.

Your safety and continued satisfaction with your Volvo and the Volvo organization are very important to us. We apologize for any inconvenience this may cause, and we appreciate your cooperation in arranging to have this important service completed as quickly as possible.

Sincerely,

A handwritten signature in blue ink that reads "Bill Casey".

Bill Casey  
Customer Care Operations Manager



July 2017

VIN: «VIN»  
Recall Campaign: R89716

## **IMPORTANT RECALL NOTICE**

Dear Volvo Owner:

This notice is sent to you in accordance with the requirements of the Motor Vehicle Safety Act.

Volvo Car Canada LTD (Volvo) on behalf of Volvo Car Group has decided that a defect which relates to motor vehicle safety exists in certain model year 2017 XC90 vehicles.

### **The reason for Recall R89716:**

The Micro Gas Generator (MGG), a subcomponent part used within the right hand side seat belt retractor for the third row seats, may detach after the seatbelt retractor pretensioner is deployed. Although, the seat belt will operate as intended in the event of a crash, if the MGG detaches, it may be a projectile within the vehicle cabin, increasing the risk of injury.

The corrective action is to replace the 3rd row passenger's side seatbelt retractor **performed at no cost.**

### ***What you need to do:***

Please contact your authorized Volvo retailer for an appointment. The repair procedure will be **performed at no cost** and can take up to 1.0 hour to complete. **However, the time your Volvo retailer requires to service your vehicle may be slightly longer depending on the vehicle.**

If you previously paid to have this corrective action performed, prior to the date on this letter, your authorized Volvo retailer will honor your receipt with a refund. Please contact your authorized Volvo retailer service department for details.

If you no longer own the vehicle described in this letter, please help us to update our records by sending us updated owner information using the contact information below.

***Please contact:***

If you have any questions, please contact your authorized Volvo retailer. If your retailer is unable to answer your questions, please contact Volvo Customer Relations at 1-800-663-8255, Monday through Friday, 8:30 A.M. to 5:00 P.M. EST or by e-mail at [vcust@volvoforlife.com](mailto:vcust@volvoforlife.com). You may also write to us at 9130 Leslie St. Suite 101, Richmond Hill, Ontario, Canada L4B 0B9.

*Federal law requires that any vehicle lessor receiving this recall notice must forward a copy of this notice to the lessee within ten days. Lessor means a person or entity that is the owner, as reflected on the vehicle title, of any five or more leased vehicles.*

We have advised Transport Canada that we are conducting this recall.

Thank you for being a member of the Volvo family. We hope you will appreciate our efforts to continually provide you with updated information of importance to your safety and the quality of your Volvo vehicle.

Sincerely,

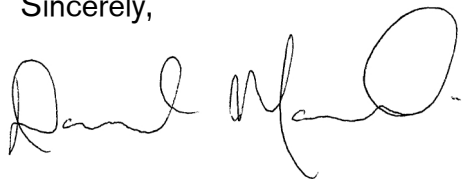
A handwritten signature in black ink, appearing to read "Daniel Martin". The signature is fluid and cursive, with a large loop at the end.

Daniel Martin  
Director, Customer Service



Juillet 2017

NIV : «VIN»

Campagne de rappel : R89716

## **AVIS DE RAPPEL IMPORTANT**

Cher propriétaire d'un véhicule Volvo,

Cet avis vous est envoyé conformément aux exigences de la Loi sur la sécurité automobile.

Volvo Cars du Canada Ltée (Volvo), au nom de Volvo Car Group, a déterminé qu'une défectuosité reliée à la sécurité automobile existe sur certains véhicules XC90 de l'année modèle 2017.

### **Raison du rappel R89716 :**

Le microgénérateur de gaz, une sous-composante située dans l'enrouleur de la ceinture de sécurité du côté droit des sièges de troisième rangée, peut se détacher après le déploiement du prétendeur de ceinture de sécurité. Toutefois, dans l'éventualité d'un accident, la ceinture de sécurité fonctionnera normalement. Si le microgénérateur de gaz se détache, il pourrait constituer un projectile dans l'habitacle, augmentant ainsi le risque de blessures.

Pour corriger le problème, il faut remplacer le prétendeur de ceintures de sécurité du siège du côté passager de la troisième rangée. La réparation sera **effectuée sans frais**.

### ***Ce que vous devez faire :***

Veillez communiquer avec votre détaillant Volvo pour fixer un rendez-vous. La procédure de réparation sera **effectuée sans frais** et prendra environ une heure. **Toutefois, selon le véhicule, il se peut que votre détaillant Volvo ait besoin d'un peu plus de temps pour effectuer l'entretien.**

Si vous avez déjà payé pour cette correction avant la date de cette lettre, votre détaillant Volvo remboursera votre facture. Veuillez communiquer avec le service à la clientèle de votre détaillant Volvo pour obtenir plus de détails.

Si vous ne possédez plus le véhicule décrit dans cette lettre, veuillez nous aider à mettre nos dossiers à jour en nous faisant parvenir les coordonnées du propriétaire actuel du véhicule à l'adresse indiquée ci-dessous.

***Pour communiquer avec nous :***

Pour toute question, veuillez communiquer avec votre détaillant Volvo. Si celui-ci n'est pas en mesure de répondre à toutes vos questions, veuillez communiquer avec le service des relations avec la clientèle de Volvo au 1-800-663-8255, du lundi au vendredi, entre 8 h 30 et 17 h HNE ou encore par courriel à l'adresse [vlcust@volvoforlife.com](mailto:vlcust@volvoforlife.com). Vous pouvez aussi nous écrire au 9130, rue Leslie, bureau 101, Richmond Hill (Ontario) Canada L4B 0B9.

*La loi fédérale requiert que tout locateur de véhicule transfère cet avis au locataire dans les dix jours suivant sa réception. Le locateur est la personne physique ou morale qui possède, comme indiqué sur le titre de propriété du véhicule, cinq véhicules loués ou plus.*

Nous avons avisé Transports Canada que nous effectuons ce rappel.

Cordialement,

A handwritten signature in black ink, appearing to read 'Daniel Martin', with a stylized flourish at the end.

Daniel Martin  
Directeur, Service à la clientèle