



SI M01 01 16
Warranties

July 2016
Technical Service

N18 Engine High-Pressure Fuel Pump (HDP): Limited Warranty Extension to 10 Years/120,000 Miles

This Service Information bulletin supersedes SI M01 01 16 dated March 2016.

MODEL

R55 (Cooper S Clubman) Model Years 2011 and 2012 produced from 05/11/2010 to 02/29/2012	R56 (Cooper S) Model Years 2011 and 2012 produced from 07/23/2010 to 02/29/2012	R57 (Cooper S Convertible) Model Years 2011 and 2012 produced from 03/23/2010 to 02/29/2012	R58 (Cooper S Coupe) Model Year 2012 produced from 03/22/2011 to 02/29/2012
R59 (Cooper S Roadster) Model Year 2012 produced from 07/05/2011 to 02/29/2012	R60 (Cooper S Countryman, Cooper S Countryman ALL4) Model Years 2011 and 2012 produced from 06/15/2010 to 02/29/2012		With the N18 engine

INFORMATION

For the above-referenced vehicles, MINI USA, a division of BMW of North America, LLC ("MINI USA") is extending the limited warranty for the engine's **High-Pressure Fuel Pump (HDP)** to:

- 10 years/120,000 miles as determined by the vehicle's original in-service date

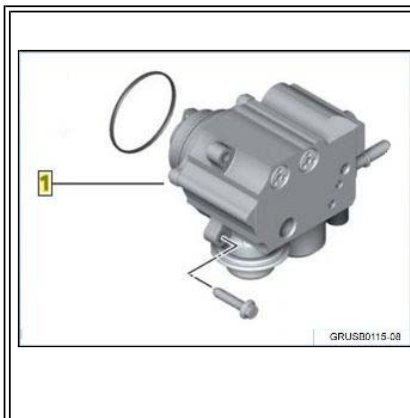

- **Item #1:** This "**component-specific**" limited warranty extension applies to defects in materials and workmanship and is subject to the applicable vehicle and coverage eligibility requirements, exclusions and limitations that apply to the New MINI Passenger Car Limited Warranty.
- **Important Note:** This limited warranty extension only applies to the listed vehicles produced up to and including 2/29/2012 (Leap year).
- Vehicles produced on or after 3/1/2012 are fitted with different equipment.



Warning: This bulletin is notice of a "limited warranty extension." This is **NOT** a notice of a

Recall or Service Action.

There is no immediate repair required unless the MINI vehicle is currently experiencing this problem.

Even though this is **NOT** a Recall, MINI USA will be sending VIN-specific customer notification letters in a

phased release.

Customer Notification Letter – VIN and Component-specific Warranty Extension

Even though this is **NOT** a Recall, MINI USA will be sending VIN-specific customer notification letters in a phased release.

ELIGIBLE MINI VEHICLES

To assist you in identifying the eligible vehicles, the DCSnet Warranty Vehicle Inquiry has been updated with the “Vehicle Comment” shown below:

MINI USA, a division of BMW of North America, LLC has extended this vehicle’s High-Pressure Fuel Pump (HDP) limited warranty to 10 years or 120,000 miles as determined from the original in-service date. This component-specific limited warranty extension is subject to all the applicable vehicle and coverage eligibility requirements, exclusions and limitations that apply to the MINI New Passenger Vehicle Limited Warranty. Please see SI M01 01 16.



Warning: Always check the DCSnet Warranty Vehicle Inquiry “Vehicle Comments” and the

“Repair History (Claims)” sections first before performing any repairs.

PARTS INFORMATION



NOTE: Please refer to the Electronic Parts Catalog (ETK/EPC), using the customer’s VIN to

locate the applicable replacement part numbers.

Important Notes:

- **Only order these parts in the quantities needed to address customers’ vehicles that have confirmed failures.**
- **“Only in conjunction with” parts:** When applicable, if ETK/EPC identifies additional part(s) that must also be replaced/installed together with the replacement of this component. These “required” additional items are also covered “in-conjunction” and under the terms of this extended limited warranty.
- Also refer to ETK/EPC and the repair instructions for onetime-use fasteners/screws and other information regarding repair-related gaskets, seals, fluid and/or lubricants that also need to be replaced/used and claimed.



WARRANTY INFORMATION

The N18 engine high-pressure fuel pump (HDP) limited warranty extension to 10 years/120,000 miles applies to “eligible US-specification MINI vehicles” that are registered, operated and have their covered repair performed by an authorized MINI dealer in the United States (including Puerto Rico).

This coverage supersedes the coverage that is provided under the MINI NEXT Certified Pre-Owned Program or any BMW Group Vehicle Service Contract that applies to the vehicle.

Should the high-pressure fuel pump fail again, this component is covered by the remaining portion of the extended limited warranty coverage period.

The existing limited warranty coverage for all other parts has not changed.

Non-Qualifying Repairs

Non-US specification vehicles, ineligible vehicles, eligible vehicles operated and repaired outside the United States and Puerto Rico and/or the diagnosis and repair of other unrelated issues are not covered under the terms of this limited warranty extension.

Qualifying Repairs - Claim Submission

Claim this work with the defect code and labor operations provided below.

Defect Code:	13 51 90 14 00	High Pressure Fuel Pump (HDP) - Limited Warranty Extension
---------------------	-----------------------	-------------------------------------------------------------------

Performing Diagnosis Test Module(s) and Troubleshooting

Labor Operation:	Labor Allowance:	Description:
00 00 006	Refer to KSD2	Performing "vehicle test" (with vehicle diagnosis system – checking faults)
And:		
61 21 528	Refer to KSD2	Connect an approved battery charger/power supply (indicated in KSD2 as "Charging battery")
And, as necessary:		
61 00 006	Work time (WT)	Performing vehicle diagnosis – test module
And/or, as necessary:		
13 31 529	Refer to KSD2	Check delivery pressure of fuel pump
And:		
13 51 520	Refer to KSD2	Replacing high-pressure (fuel) pump (after vehicle diagnosis)

If you are using a Main labor code for another repair, use the Plus code labor operation 00 00 556 instead.

Work time labor operation code 61 00 006 is not considered a Main labor operation; however, it does require an individual punch time and an explanation on the repair and in the claim comments section.

Or, there is an:

External Leak

Labor Operation:	Labor Allowance:	Description:
13 51 017 	Refer to KSD2	Replacing high-pressure (fuel pump)
And, as necessary:		
13 99 000	Work time (WT)	Work time to visually inspect and determine the source of the leak

UPDATE!

If you are using a Main labor code for another repair, use the Plus code labor operation 13 51 517 instead.

Work time labor operation code 13 99 000 is not considered a Main labor operation; however, it does require an individual punch time and an explanation on the repair order in the claim comments section.

Refer to KSD2 for the corresponding flat rate unit (FRU) allowances.

And, if needed:

Sublet – Bulk Materials

Sublet Code 4	See sublet reimbursement calculation below	Reimbursement for the repair-related bulk materials (MINI part number, please do not use the part numbers for claim submission)
---------------	--------------------------------------------	---------------------------------------------------------------------------------------------------------------------------------

Sublet reimbursement calculation for claiming the “used quantities” of repair-related bulk materials (MINI part numbers) is at dealer net plus your dealer’s handling.

Enter this material cost in sublet and itemize the amount on the repair order and in claim comment section.

Previous Customer-pay Repairs – Limited Warranty Extension Reimbursement

Under this extended limited warranty, MINI USA, a division BMW of North America, LLC (“MINI USA”) will provide reimbursement for “qualifying customer-pay repairs” that were performed on an eligible vehicle prior to the release of this component-specific limited warranty extension.

Repairs that do not Qualify for Reimbursement**UPDATE!**

Repairs performed on ineligible vehicles, eligible vehicles operated and repaired outside the United States and Puerto Rico and/or the diagnosis and repair of other unrelated issues. This exclusion also applies to repairs performed using (including those repairs that result from using) non-genuine MINI parts and/or used passenger car parts.

Customer-pay Invoice Review and Reimbursement Procedure

1. Review and verify that the previous customer-pay invoice (MINI dealer or independent repair shop) contains a qualifying repair to replace the component that is identified in this Service Information bulletin.
2. If this prior repair qualifies, reimburse the customer (labor and parts).
3. Submit for this customer-paid repair expense under **Defect Code 85 10 03 02 NA**, as follows:
 - o Sublet Code 3
 - o Dollar amount (with no markup)
 - o Comment: High-Pressure Fuel Pump Limited Warranty Extension - Reimbursement for allowable expenses that relate to performing a qualifying prior customer-pay repair.
 - o Itemize the sublet amount on the repair order and in the claim comments
4. Retain the “original” customer pay invoice in your files; this documentation may be requested by MINI during the claim review process.

[Copyright ©2016 BMW of North America, Inc.]