

NUMBER: SC-17-90-04

DATE: July 2017

MODEL: Karma Revero

First Release

TITLE: 12 Volt Reset and Isolation Procedure

PRIORITY: All Karma Revero Vehicles

MARKET REGION: All

PURPOSE:

This service tip contains instructions on how to perform a manual 12 Volt system disconnect, reset, and any 12 volt system isolation in the Karma Revero sedan produced for the 2017 & 2018 model year.

This is also an applicable procedure to prepare the vehicle for long term storage; especially when the duration is expected to exceed the capacity of the high voltage battery maintenance capabilities for the 12 volt battery.

PROCESS OVERVIEW:

1. Power off
2. Fuse box legend and fuse location
3. Disconnecting the proper fuse
4. Disconnecting the 12 volt harness
5. Reversal of procedure

<p>NOTE: Before disconnecting the 12 volt battery, the vehicle should be placed in PARK. The parking brake should NOT be applied.</p>
--

NUMBER: SC-17-90-04

DATE: July 2017

MODEL: Karma Revero

First Release

TITLE: 12 Volt Reset and Isolation Procedure

- 1) Power off- wait for car to go to sleep (45sec-1 minute)
- 2) Disconnect #10 solar panel fuse;
"SPBC and HVAC"

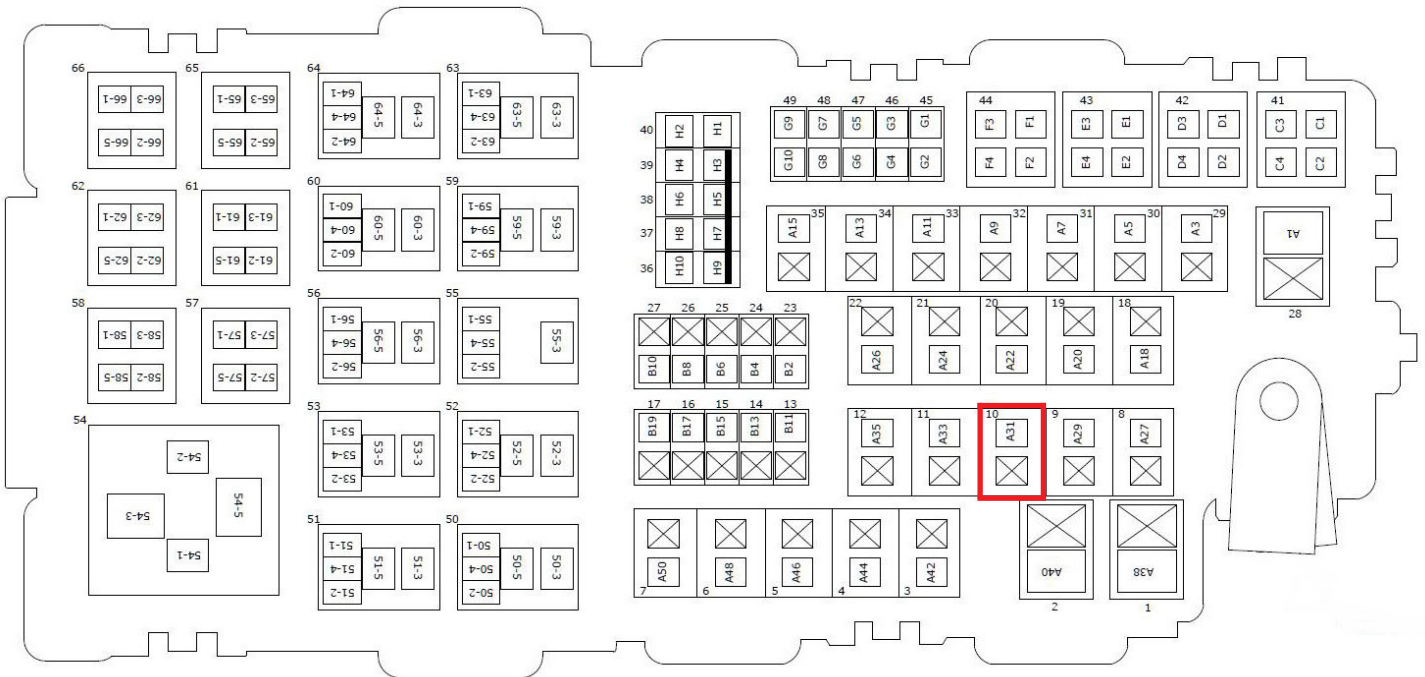

Karma Automotive Bulletins and service documents are intended for use by experienced and trained Technicians. If you lack the skills, tools, equipment and a suitable workshop for any procedure described in this document, we suggest you leave such repairs to a Karma retailer and service provider. See your service provider for advice on whether your vehicle may benefit from the information contained within this document. The information contained in the Karma Bulletin is accurate at the date of publication. However, Karma Automotive regularly updates technical information. Please check with your Karma Automotive Retailer and Karma Automotive service provider that the bulletin you intend to use contains the latest available information.

NUMBER: SC-17-90-04

DATE: July 2017

MODEL: Karma Revero

First Release

TITLE: 12 Volt Reset and Isolation Procedure

- 3) Disconnect the 12 volt main connector (under hood- on right fender)
- 4) Wait 30 seconds

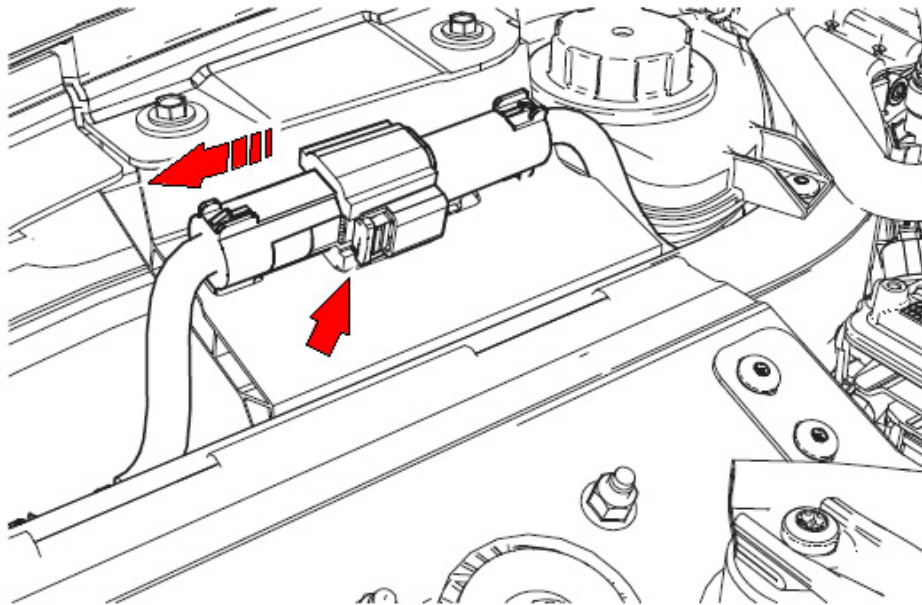

NOTE: If the 12 volt battery has been disconnected; use the mechanical key to open the right-front door and gain entry to the vehicle, if required.

- 5) Reconnect 12 volt main connector
- 6) Reinstall Fuse #10 for solar roof (SPBC)

Karma Automotive Bulletins and service documents are intended for use by experienced and trained Technicians. If you lack the skills, tools, equipment and a suitable workshop for any procedure described in this document, we suggest you leave such repairs to a Karma retailer and service provider. See your service provider for advice on whether your vehicle may benefit from the information contained within this document. The information contained in the Karma Bulletin is accurate at the date of publication. However, Karma Automotive regularly updates technical information. Please check with your Karma Automotive Retailer and Karma Automotive service provider that the bulletin you intend to use contains the latest available information.