

**TECHNICAL INSTRUCTIONS  
FOR  
WARRANTY ENHANCEMENT PROGRAM ZH8**

\* \* \* \* \*

**CERTAIN 2005-2007 MODEL YEAR SEQUOIA**

\* \* \* \* \*

**FRAME REPLACEMENT**

The repair quality of covered vehicles is extremely important to Toyota. All dealership technicians performing this recall are required to successfully complete the most current version of the E-Learning course "Safety Recall and Service Campaign Essentials". To ensure that all vehicles have the repair performed correctly; technicians performing this repair are required to currently hold at least one of the following certification levels:

- Certified Technician (any specialty)
- Expert Technician (any specialty)
- Master Technician
- Master Diagnostic Technician

Final repair must be signed off and validated by a MDT, Shop Foreman or Service Manager using the Frame Replacement Inspection Form.

It is the dealership's responsibility to select technicians with the above certification level or greater to perform this recall repair. Carefully review your resources, the technician skill level, and ability before assigning technicians to this repair. It is important to consider technician days off and vacation schedules to ensure there are properly trained technicians available to perform this repair at all times.

# I. OPERATION FLOWCHART

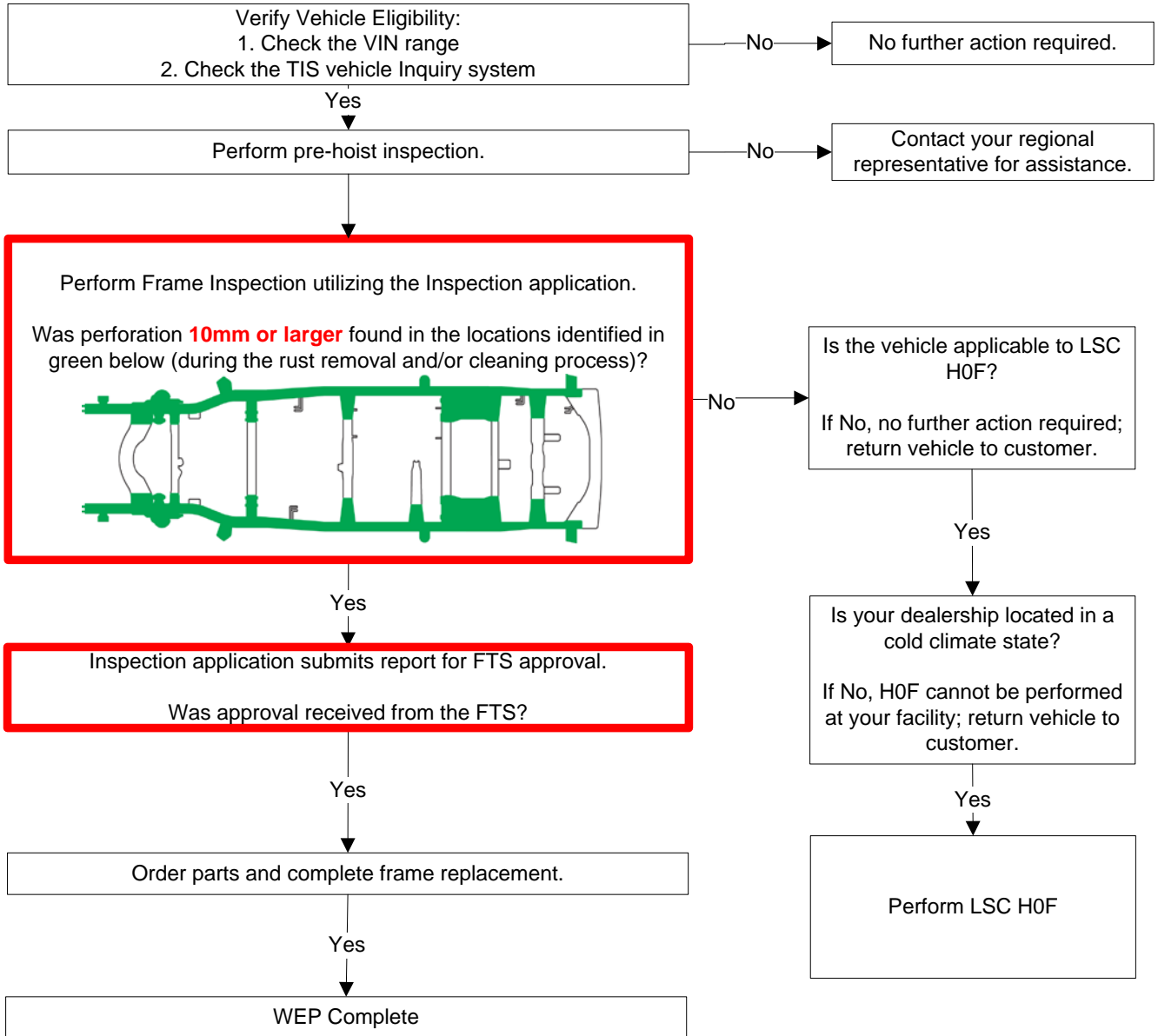

## II. PREPARATION

### A. TOOLS & EQUIPMENT

- A/C service equipment
- Alignment rack
- Brake bleeder
- Engine Hanger
  - 1GR-FE Engine
    - 12281-31060 – Engine hanger no. 1 (Qty: 1)
    - 12282-31040 – Engine hanger no. 2 (Qty: 1)
    - 90119-08A87 – Bolt (Qty: 4)
  - 3UR-FE Engine
    - 12281-38150 – Engine hanger no. 1 (Qty: 2)
    - 90119-14120 – Bolt (Qty: 2) (Japan sourced parts)
    - 90119-A0166 – Bolt (Qty: 2) (Local sourced parts)
- Engine hoist (Qty: 2) or Hydraulic mini crane (Qty: 2)
- Engine sling (Qty: 2)
- Floor jack
- Protective eyewear
- Protective gloves
- Ratcheting tie down strap (2 in X 27 ft, minimum work load capacity: 3,000 lbs)
- Special Service Tools (SST)
  - 09985-20010 – Air conditioner service tool set **or** Commercially available air conditioning manifold gauge set
  - 09325-40010 – Transmission oil plug (Transmission A750E)
  - 09325-60010 – Transmission oil plug (Transmission AB60E)
  - 09610-20012 – Pitman arm puller
  - 09520-32040 – A component of SST 09520-24010, Differential side gear shaft puller
  - 09520-01010 – Drive shaft remover attachment
  - 09951-04010,09952-04010,09953-04020,09954-04010,09955-04031,09958-04011, – A component of SST 09950-40011, Puller B set
  - 09955-04090 – Craw no.9
  - 09922-10010-01 – Variable open wrench
- Standard hand tools
- Techstream
- Torque wrench
- Torx® T55H tamper resistant socket
- Socket wrench 39mm
- Hexagon wrench 8, 10
- Deep socket wrench 10, 12, 14, 17, 19, 24mm
- Union Nut Wrench 10mm
- Weights

### B. SUPPLIES

- Toyota Genuine ATF WS or DEXRON® III (DEXRON® II) – As needed
- Hypoid gear oil API GL-5 SAE 75W-90 – 2.1 liter
- R134a refrigerant – As needed
- Toyota DOT 3 brake fluid – 3 pints
- Toyota long life coolant – 2 gallons
- Paint
- MP Grease

## C. PARTS

To assist dealers in determining the correct part number(s) to order, a website has been set up to look up part numbers by VIN. Please go to <http://toyota-frame-parts-lookup.imagespm.info>, enter the VIN, and the correct part numbers to order will be displayed. **The website is for part(s) application reference only and will not order the part, nor will it confirm campaign completion status.**

- The parts will need to be ordered through the Dealer Daily Parts system.
- ETAs for the parts will be available via the normal system.
- Frame ETAs will be made available on the Dealer Daily website, in the MAC reference area.

An illustration of the parts replaced and their location(s) have been provided. Please reference the **"Illustration Name"** and **"Page"** columns in the parts tables below.

### Individual Parts:

Part Number	Part Description (Model Year)	Quantity	Illustration Name	Page
04001-7550C	Frame, Sub-Assy	1	Frame & Misc Parts	6
04001-7560C	Frame, Sub-Assy (w/Towing Hitch)	1	Frame & Misc Parts	6

### Individual Parts (Continued):

Part Number	Part Description	Quantity	Illustration Name	Page
12157-10010	Gasket, Drain Plug	1	Front Differential	15
43425-04020	Ring, Drive Shaft Snap	2	Front Suspension & Front Driveshaft	12
47322-0C070	Tube, RR Brake, No.2	1	Brake Tubes	13
47323-0C060	Tube, RR Brake, No.3	1	Brake Tubes	13
47325-0C060	Tube, RR Brake, No.5	1	Brake Tubes	13
47326-0C030	Tube, RR Brake, No.6	1	Brake Tubes	13
82164-0C041	Wire, Frame (w/o air suspension)	1	Wire Harness Clamps	15
82164-0C120	Wire, Frame (w/ air suspension)	1	Wire Harness Clamps	15
90080-11180	Bolt, w/ Washer	6	Height Control (Auto-Leveler)	11
90430-24003	Gasket	1	Front Differential	15
95381-04045	Pin, Cotter	2	Front Suspension & Front Driveshaft	12
47316-0C040	TUBE,FR BRAKE,No.6	1	BRAKE TUBE & CLAMP	10

**Parts Kits:**

Part Number	Part Description	Quantity
04001-7020C	Parts Kit No.2 – Common Replacement kit A-2 (05-07MY)	1

**The kit listed above includes the following parts:**

Part Number	Part Description	Quantity	Illustration Name	Page
16492-21050	Ring, O Radiator	1	Radiator	20
47351-34040	Bracket, Flexible Hose, No.5	1	Brake Tubes	13
47353-35110	Bracket, Flexible Hose, No.3	1	Brake Tubes	13
47354-35100	Bracket, Flexible Hose, No.4	1	Brake Tubes	13
48409-34020	Cam Sub-Assy, Toe Adjust	2	Front Suspension & Front Driveshaft	12
48409-34030	Cam Sub-Assy, Toe Adjust	2	Front Suspension & Front Driveshaft	12
48452-35020	Plate, Toe Adjust, No.2	4	Front Suspension & Front Driveshaft	12
48824-34030	Bracket, Stabilizer, RH	1	Front Suspension & Front Driveshaft	12
48829-34020	Bracket, Stabilizer, LH	1	Front Suspension & Front Driveshaft	12
77285-34031	Clamp, Fuel Tube, No.1	4	Fuel Tubes	14
90099-14121	RING, O	1	Air Conditioning	20
90119-08516	Bolt, w/ Washer	10	Front Floor Panel & Front Floor Member	22
90178-08011	Nut, Flange	4	Rear Bumper	21
90178-10024	Nut, Flange	4	Front Bumper	21
90179-08054	Nut	1	AT Shaft Cable	20
90179-08068	Nut	6	Front Floor Panel & Front Floor Member	22
90179-10071	Nut	4	Engine Mounting	17
90179-14062	Nut	1	Rear Spring & Shock Absorber	10
90182-10004	Nut, w/ Washer	2	Front Suspension & Front Driveshaft	12
90252-03015	Pin, Cotter	2	Front Suspension & Front Driveshaft	12
90460-37003	Clamp, Hose	1	Fuel Tank	19
90460-40007	Clamp, Hose	1	Fuel Tank	19
90468-08035	Clip	4	Brake Tubes	13
90904-12066	Way, 2	1	Brake Tubes	13
90904-12067	Way, 2	1	Brake Tubes	13
90904-12068	Way, 2	1	Brake Tubes	13
90917-06083	Gasket, Exhaust Pipe	2	Exhaust System	18
90917-06085	Gasket, Exhaust Pipe	1	Exhaust System	18
90949-01C06	Clamp	7	Brake Tubes	13
91621-B0816	Bolt, w/ Washer	6	Brake Tubes	13
94130-01232	Nut, Hexagon	6	Rear Bumper	21
94622-31200	Washer, Plate	6	Rear Bumper	21
95381-03225	Pin, Cotter	2	Power Steering	16

**Parts Kits (Continued):**

Part Number	Part Description	Quantity		
04001-7040C	Parts Kit No.4 – Common Replacement kit B-2 (05-07MY)	1		
<b>The kit listed above includes the following parts:</b>				
Part Number	Part Description	Quantity	Illustration Name	Page
47313-0C012	TUBE, FR BRAKE, No.3	1	Brake Tubes	13
47314-0C011	TUBE, FR BRAKE, No.4	1	Brake Tubes	13
47317-0C020	TUBE, FR BRAKE, No.7	1	Brake Tubes	13
77285-0C010	SUPPORT, FUEL RETURN & MAIN TUBE	1	Fuel Tubes	14
77285-0C020	SUPPORT, FUEL RETURN & MAIN TUBE	1	Fuel Tubes	14
89542-0C010	Sensor, Speed, Front RH	1	ABS	17
89543-0C010	Sensor, Speed, Front LH	1	ABS	17
89545-0C020	Sensor, Speed, Rear RH	1	ABS	17
89546-0C020	Sensor, Speed, Rear LH	1	ABS	17
90069-08007	RING, O	1	Air Conditioning	20
90080-11180	Bolt, w/ Washer	4	Rear Spring & Shock Absorber	10
90080-11180	Bolt, w/ Washer	4	Spare Wheel Carrier	9
90080-11180	Bolt, w/ Washer	2	Fuel Tubes	14
90080-11275	Bolt, w/ Washer	2	Front Suspension & Front Driveshaft	12
90080-11373	Bolt, w/ Washer	5	Suspension Crossmember & Under Cover	9
90080-11373	Bolt, w/ Washer	2	Fuel Tank	19
90080-11387	Bolt, w/ Washer	4	Engine Mounting	17
90080-11410	Bolt, w/ Washer	2	Front Suspension & Front Driveshaft	12
90080-11482	Bolt, w/ Washer	2	Front Suspension & Front Driveshaft	12
90080-11482	Bolt, w/ Washer	4	Rear Spring & Shock Absorber	10
90080-11491	Bolt, w/ Washer	6	Frame & Misc Parts	9
90080-11555	Bolt, w/ Washer	3	Power Steering	16
90080-46263	Clamp	1	Exhaust System	18
90119-A0026	Bolt, w/ Washer	4	Rear Bumper	21
90119-A0027	Bolt, w/ Washer	2	Rear Bumper	21
90119-A0064	Bolt, w/ Washer	4	Rear Bumper	21
90119-A0077	Bolt, w/ Washer	2	Fuel Tank	19
90119-A0085	Bolt, w/ Washer	4	Frame & Misc Parts	9
90119-A0169	Bolt, w/ Washer	8	Frame & Misc Parts	9
90179-08241	Nut	2	Fuel Tank	19

Part Number	Part Description	Quantity
04001-7050C	Parts Kit No.5 – Height Control 1 (05-07MY)	1
<b>The kit listed above includes the following parts:</b>		
Part Number	Part Name	Qty
90301-04011	RING,O 4 REAR SPRING & SHOCK ABSORBER	4
48958-35020	CLIP, PNEUMATIC CYLINDER 2 REAR SPRING & SHOCK ABSORBER	2

**Parts Kits (Continued):**

Part Number	Part Description	Quantity		
04001-7060C	Parts Kit No.6 – Height Control 2 (05-07MY)	1		
<b>The kit listed above includes the following parts:</b>				
Part Number	Part Description	Quantity	Illustration Name	Page
48932-30010	Plate, Height Control Tube	4	Height Control (Auto-Leveler)	11
48933-30010	Holder, Air Connector Clip	2	Height Control (Auto-Leveler)	11
48934-30010	Connector, Height Control Tube, No.2	4	Height Control (Auto-Leveler)	11
82711-2C250	Clamp, Wiring Harness	1	Electronic Modulated Suspension	22
82711-35280	Clamp, Wiring Harness	1	Electronic Modulated Suspension	22
82711-3F440	Clamp, Wiring Harness	1	Electronic Modulated Suspension	22
82711-48060	Clamp, Wiring Harness	1	Height Control (Auto-Leveler)	11
90179-06292	Nut	1	Height Control (Auto-Leveler)	11
90179-08025	Nut	2	Electronic Modulated Suspension	22
90301-04006	Ring, O	2	Height Control (Auto-Leveler)	11
90301-04011	Ring, O	8	Height Control (Auto-Leveler)	11
90467-09093	Clip	3	Height Control (Auto-Leveler)	11
90468-12012	Clip	2	Height Control (Auto-Leveler)	11
90949-01883	Clamp	2	Height Control (Auto-Leveler)	11
90949-01B59	Clamp	6	Height Control (Auto-Leveler)	11

Part Number	Part Description	Quantity
04007-18334	PLUG, HOLE KIT	1
<b>The kit listed above includes the following parts:</b>		
Part Number	Part Description	Quantity
90950-01539	PLUG,HOLE	2
90480-18492	PLUG,HOLE	4
90950-01A09	PLUG,HOLE	22
90950-01987	PLUG,HOLE	39
90950-01983	PLUG,HOLE	7
90950-01984	PLUG,HOLE	2
90950-01A24	PLUG,HOLE	4

## D. PARTS ILLUSTRATION

### Frame & Misc Parts

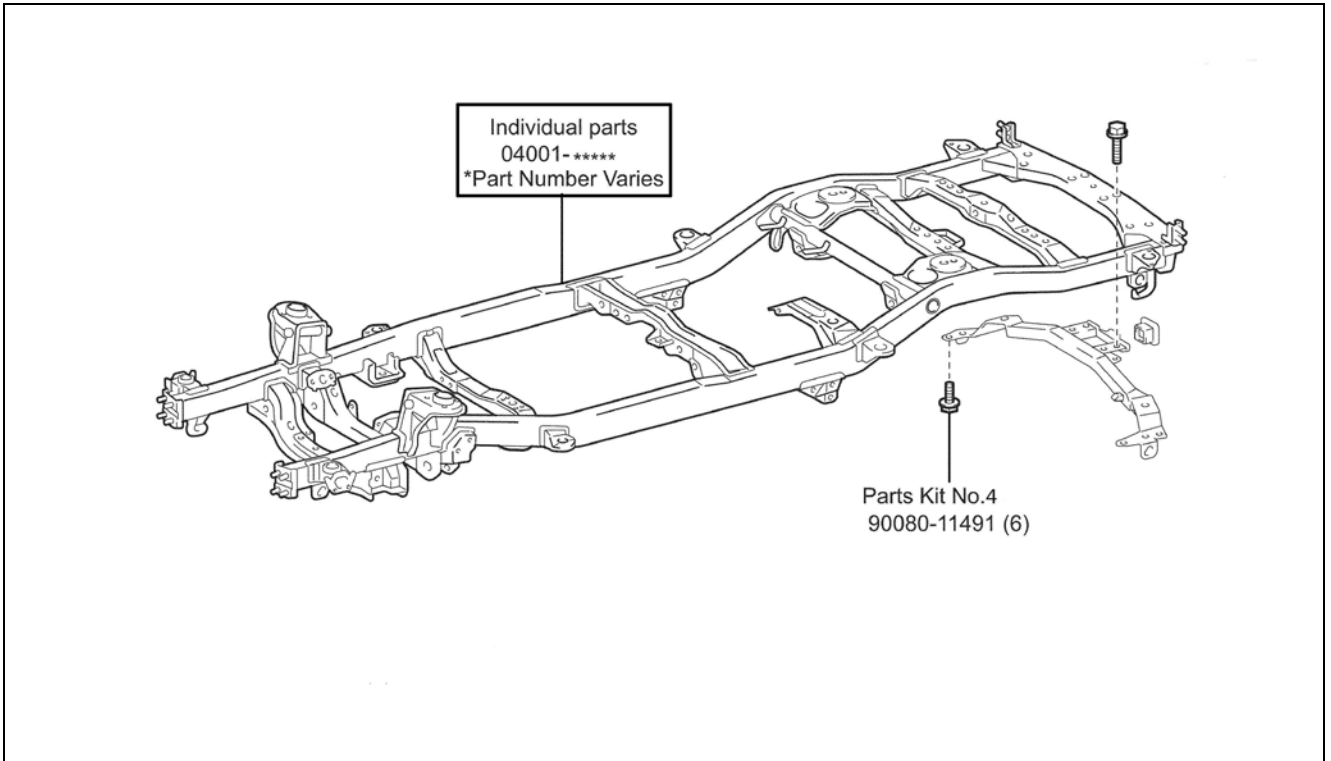

### Suspension Crossmember & Under Cover

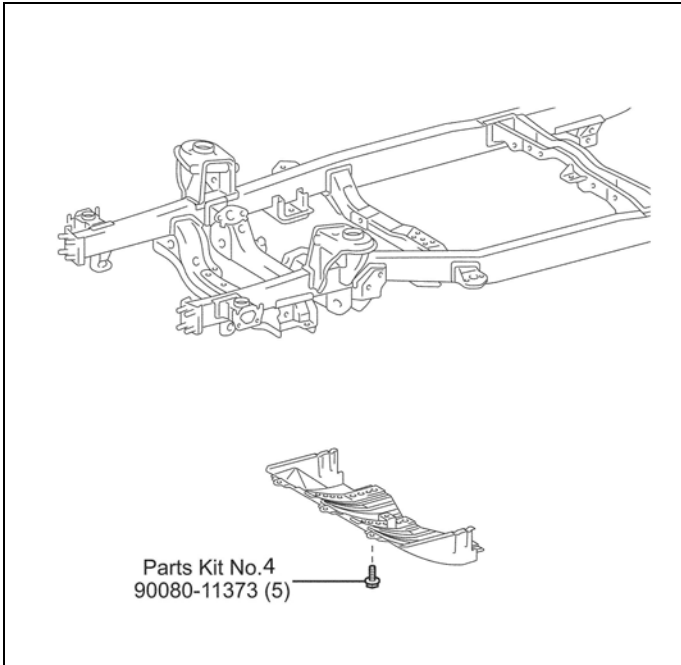

### Spare Tire Carrier

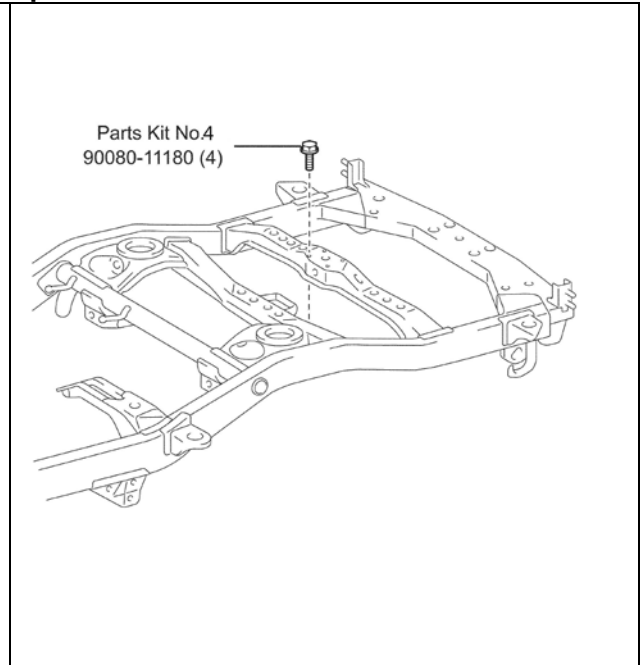



# Rear Spring & Shock Absorber

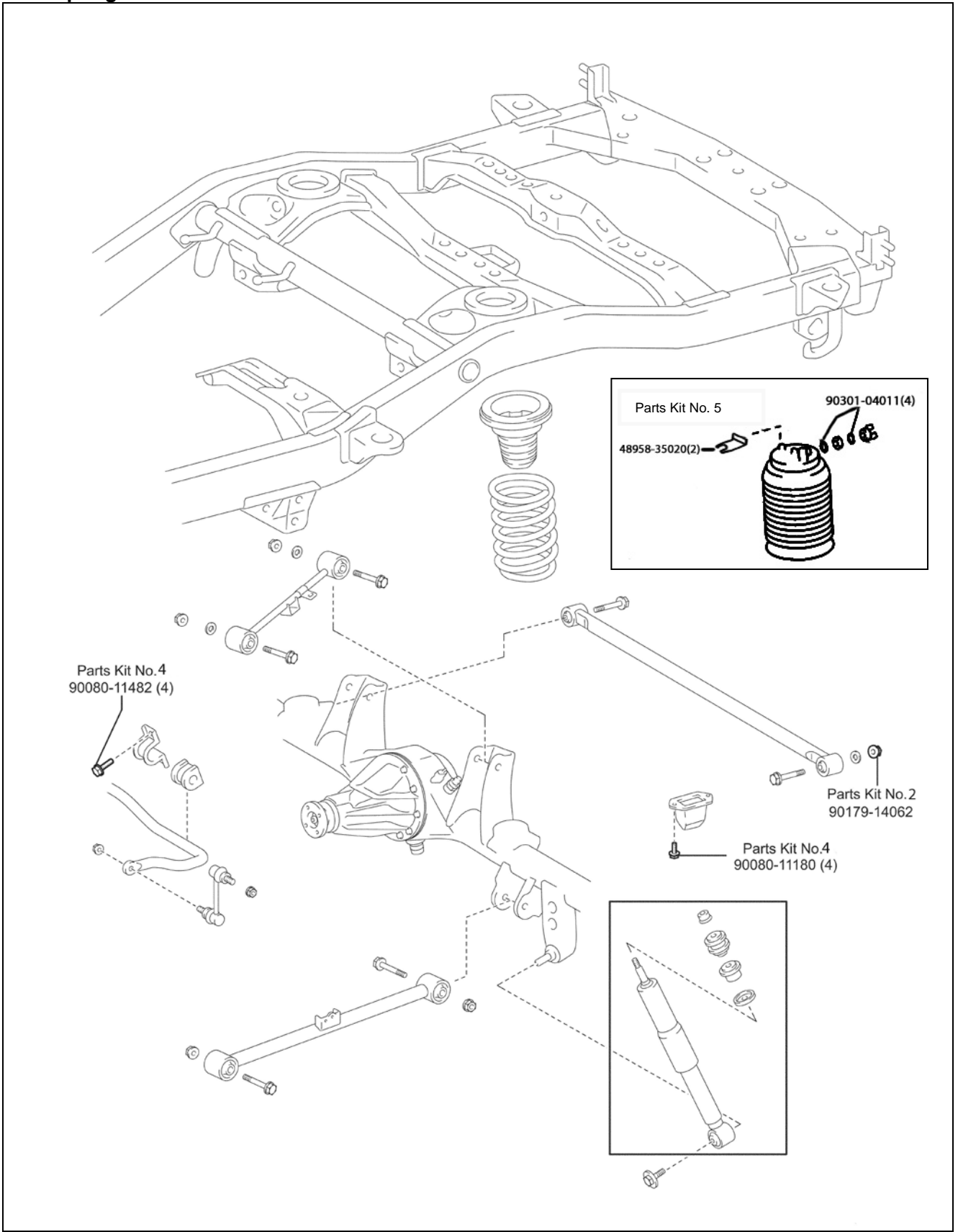

# Front Suspension & Front Driveshaft

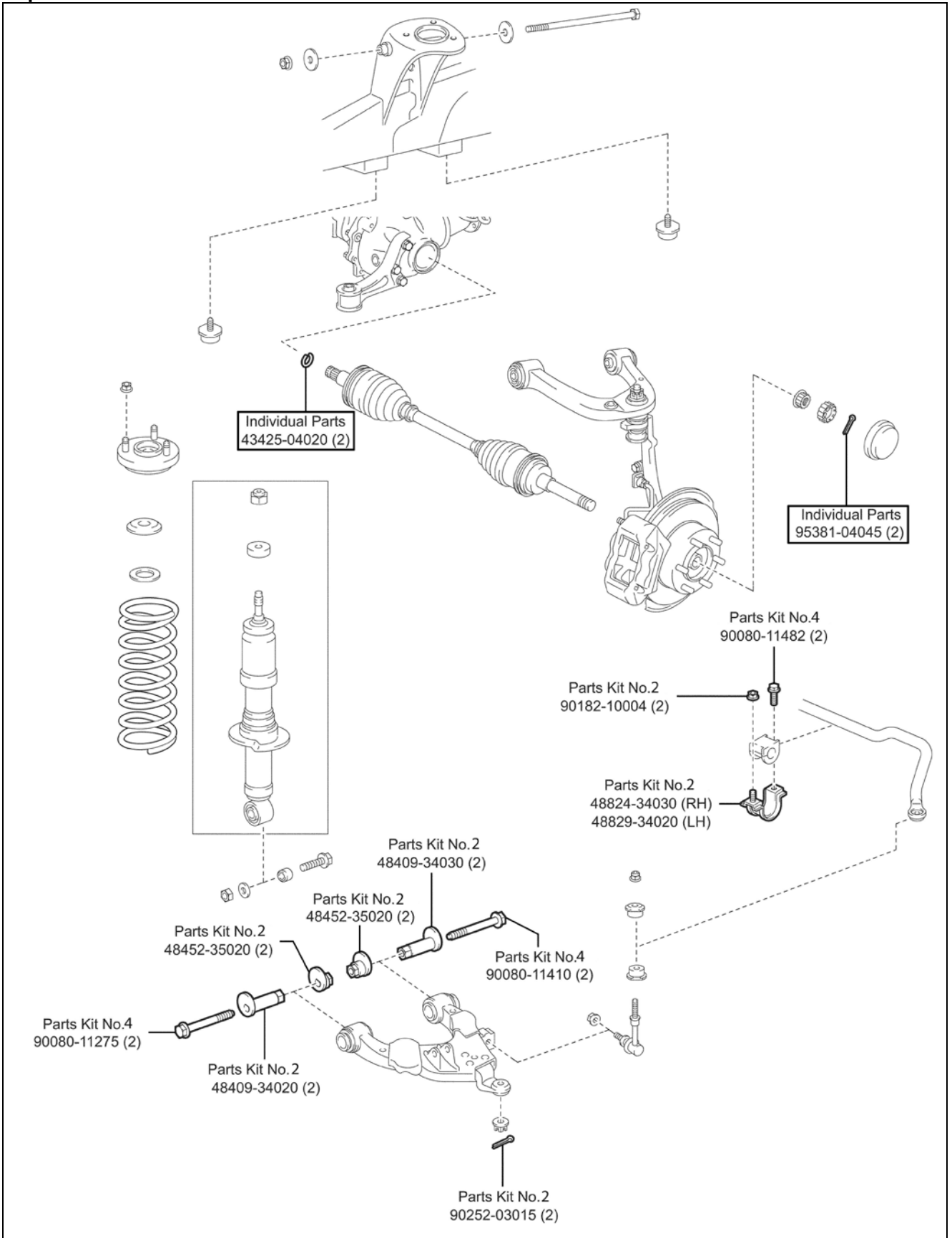

# Brake Tubes

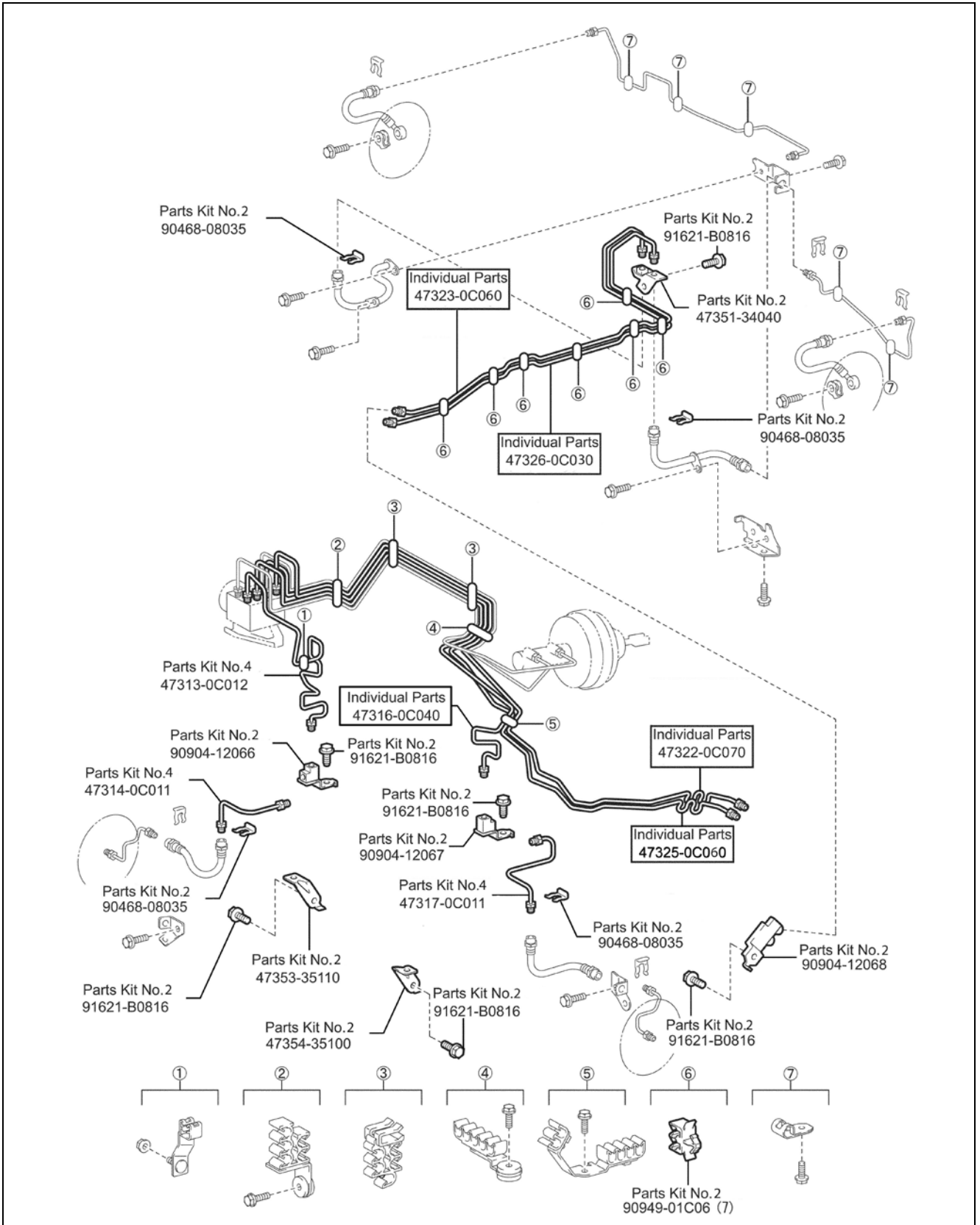

## Fuel Tubes

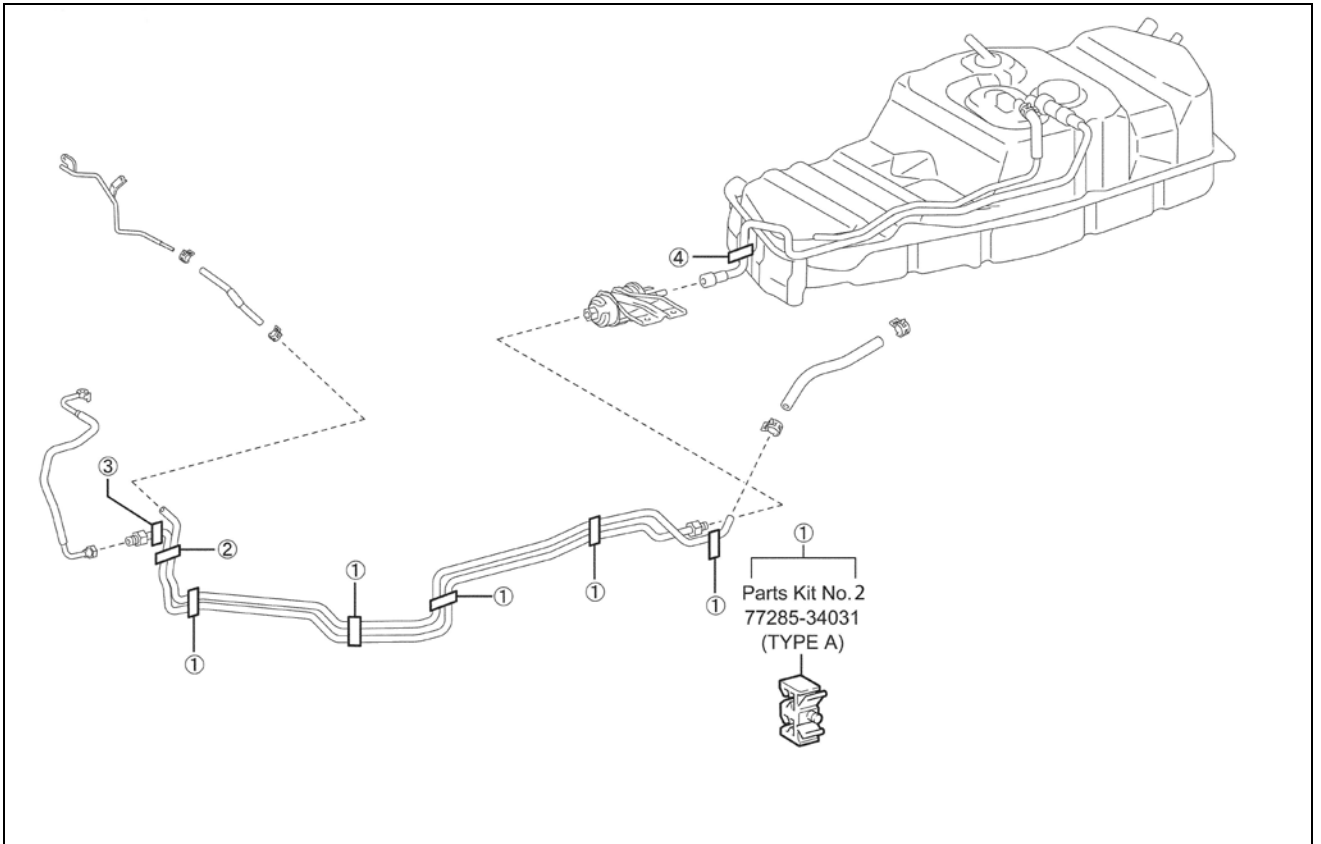

## Wire Harness Clamps

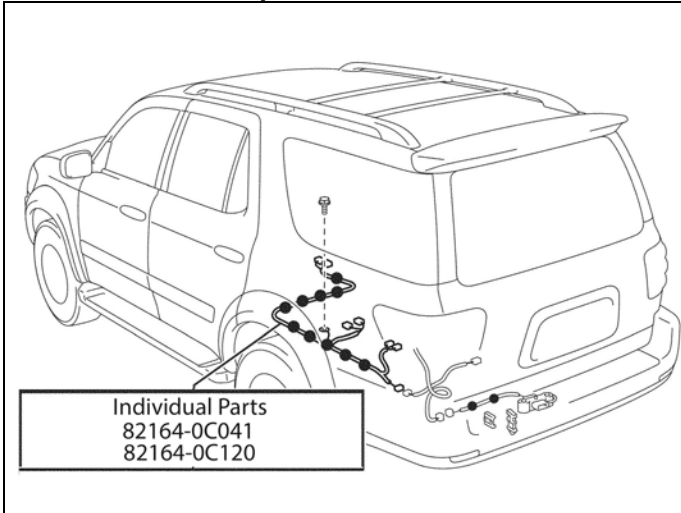

## Front Differential

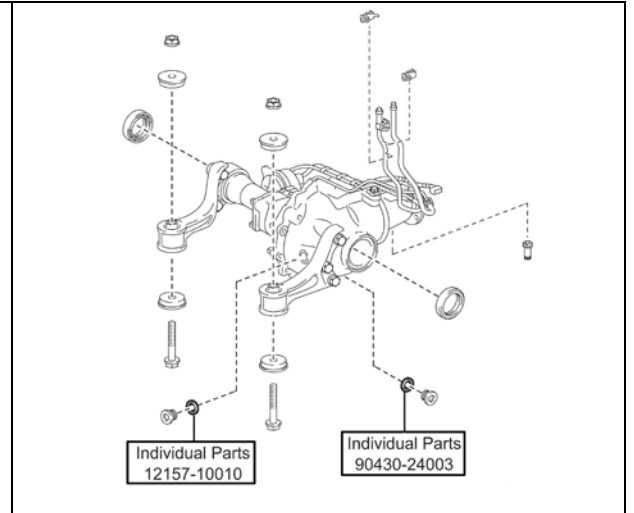

## Power Steering

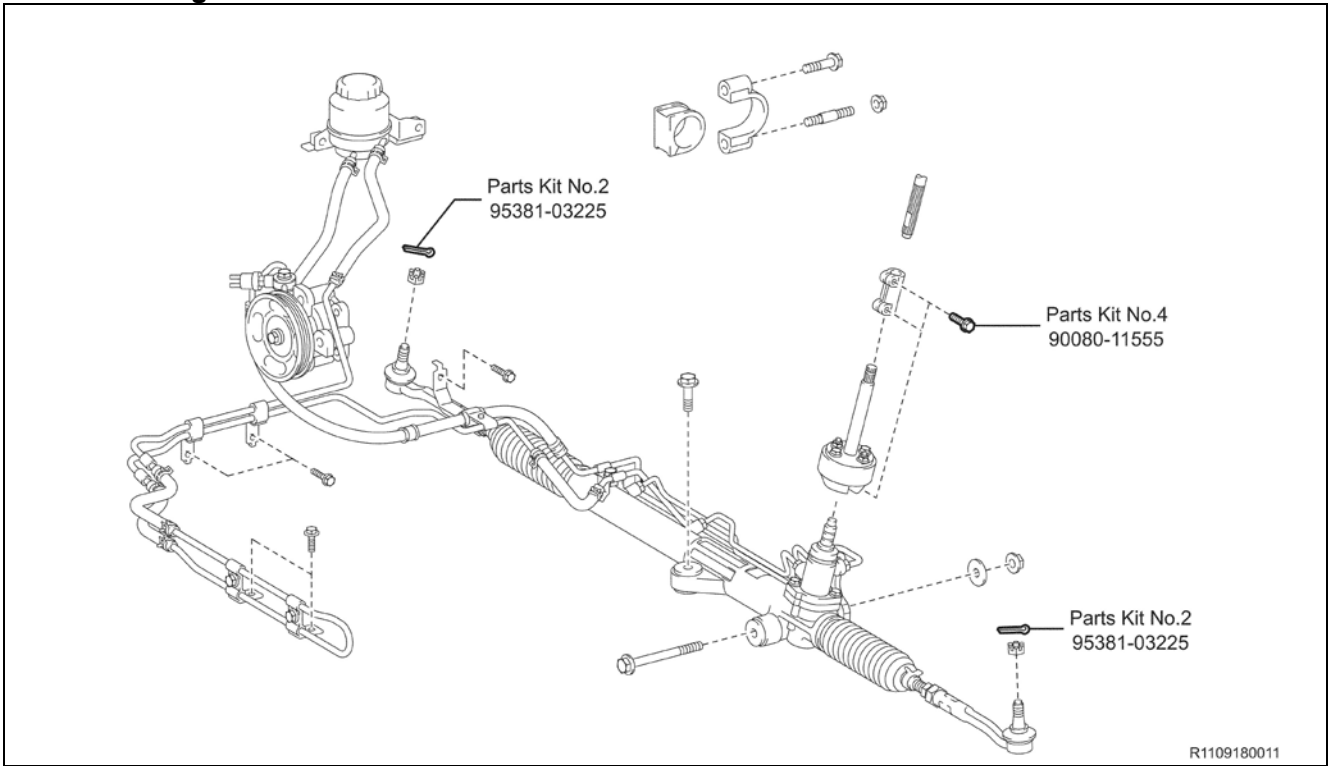

## ABS

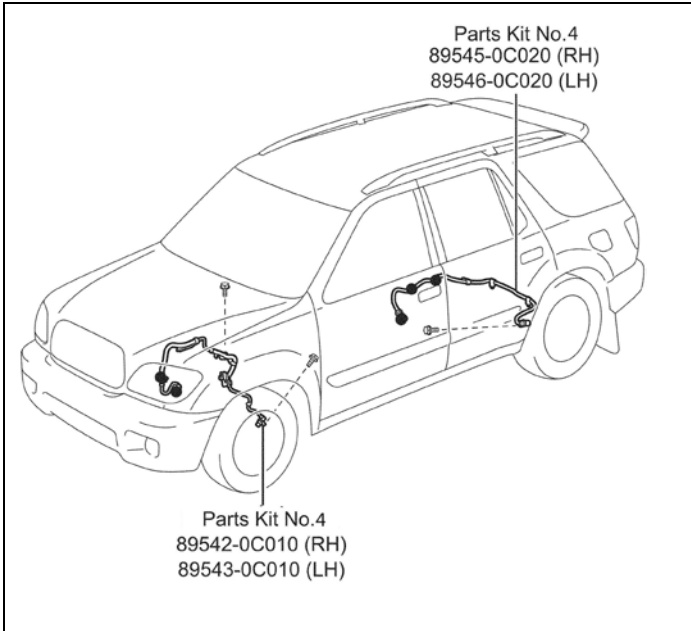

## Engine Mounting

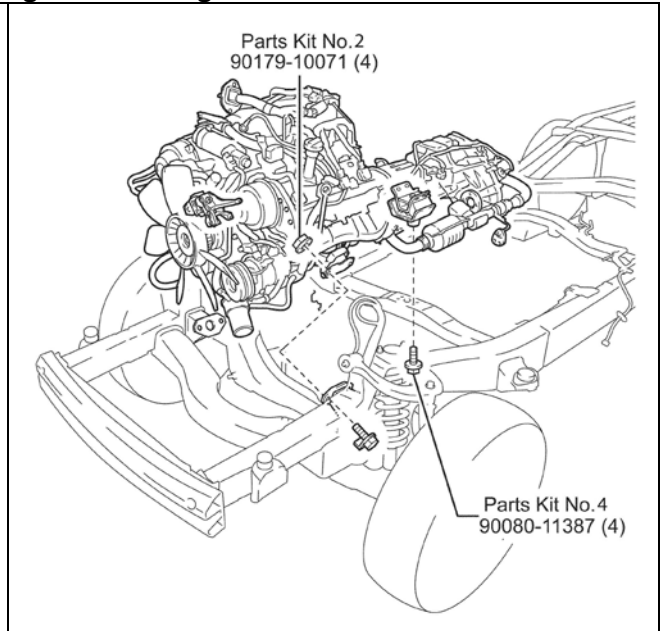

## Exhaust System

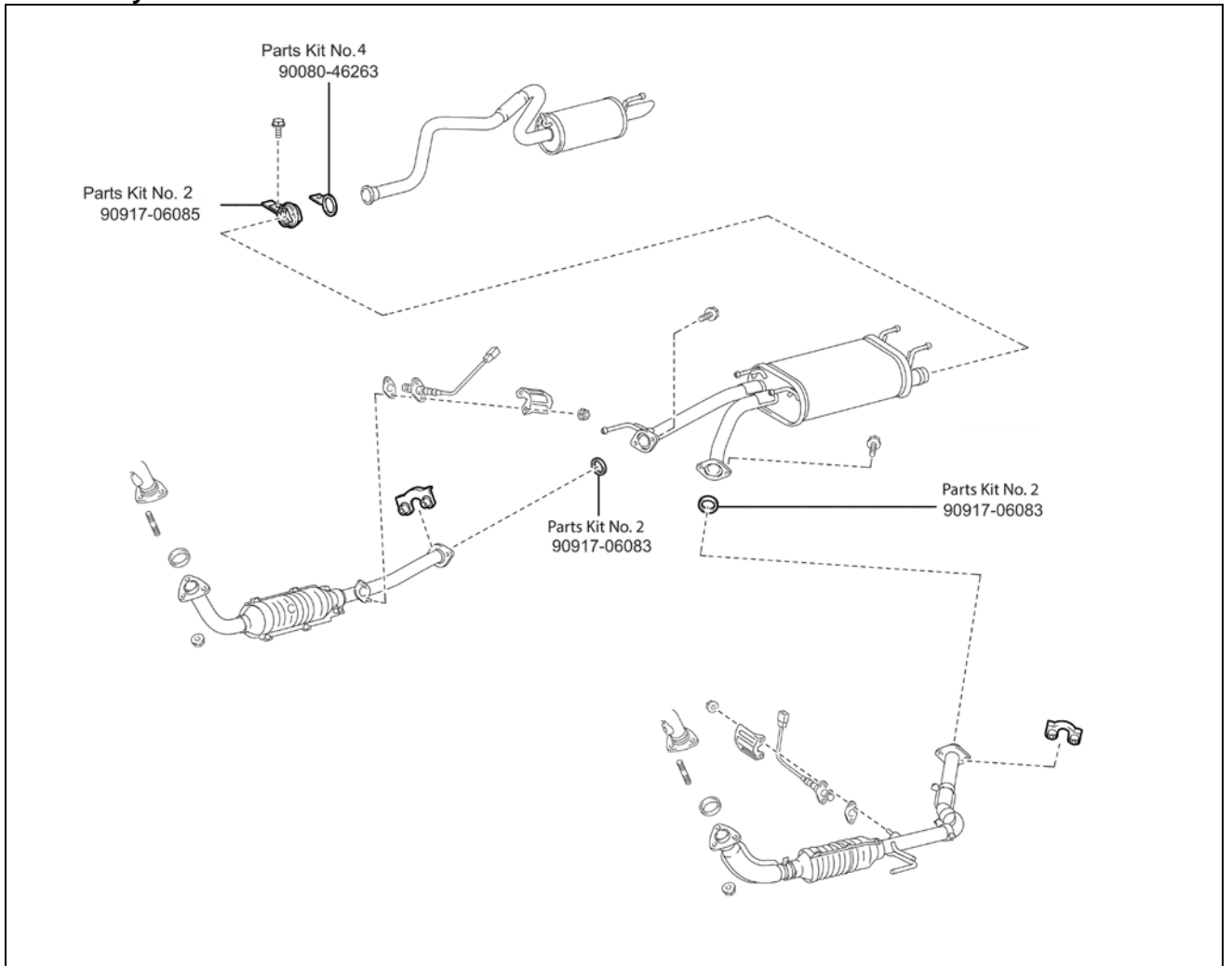

## Fuel Tank

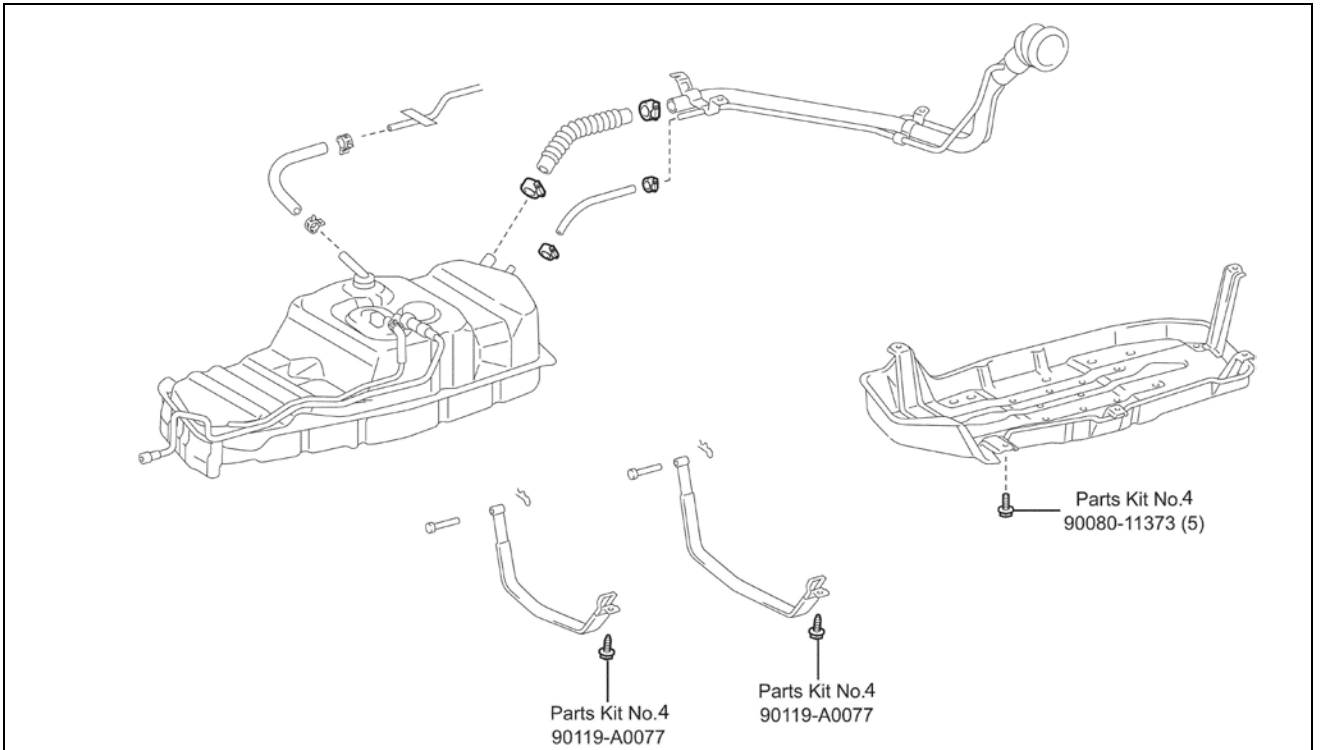

## Air Conditioning

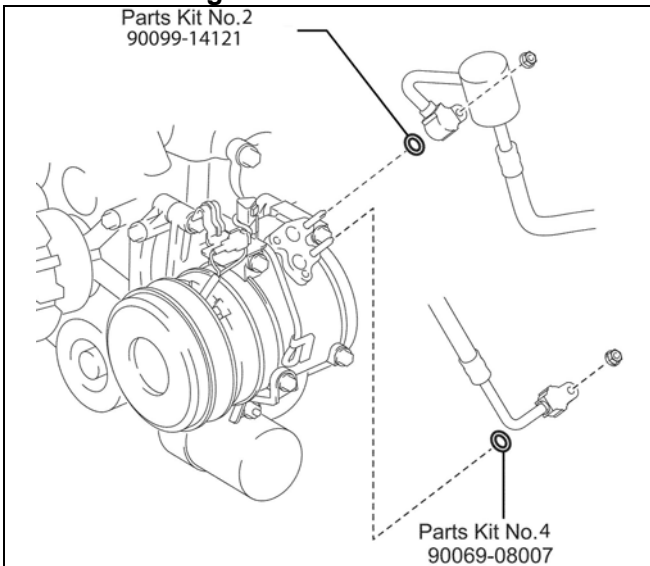

## Auto Trans Shift Cable

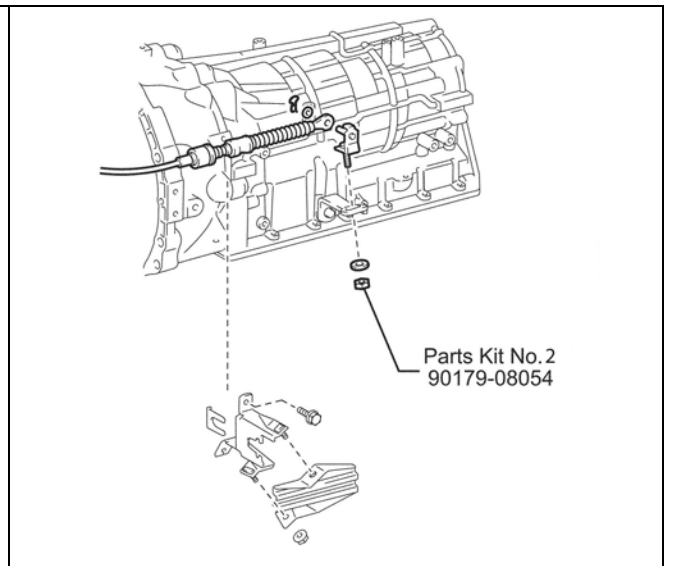

### Radiator

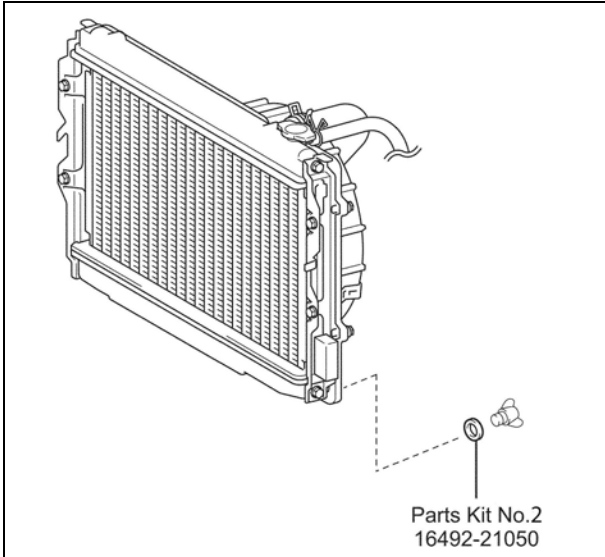

### Front Bumper

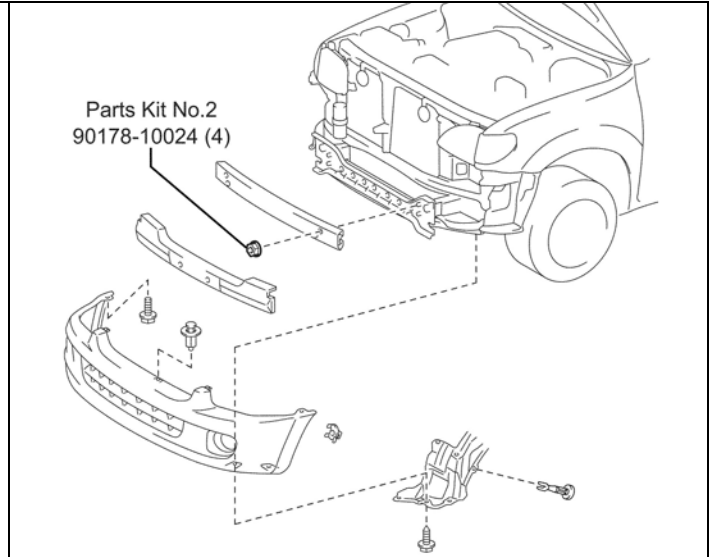

### Rear Bumper

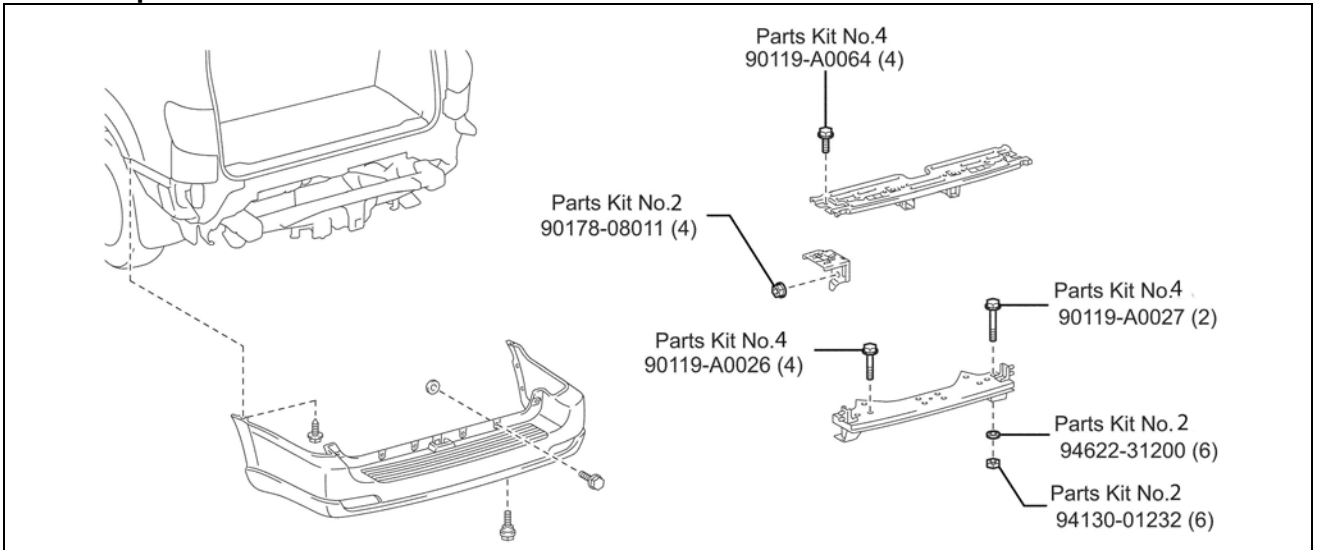



## Front Floor Panel & Front Floor Member

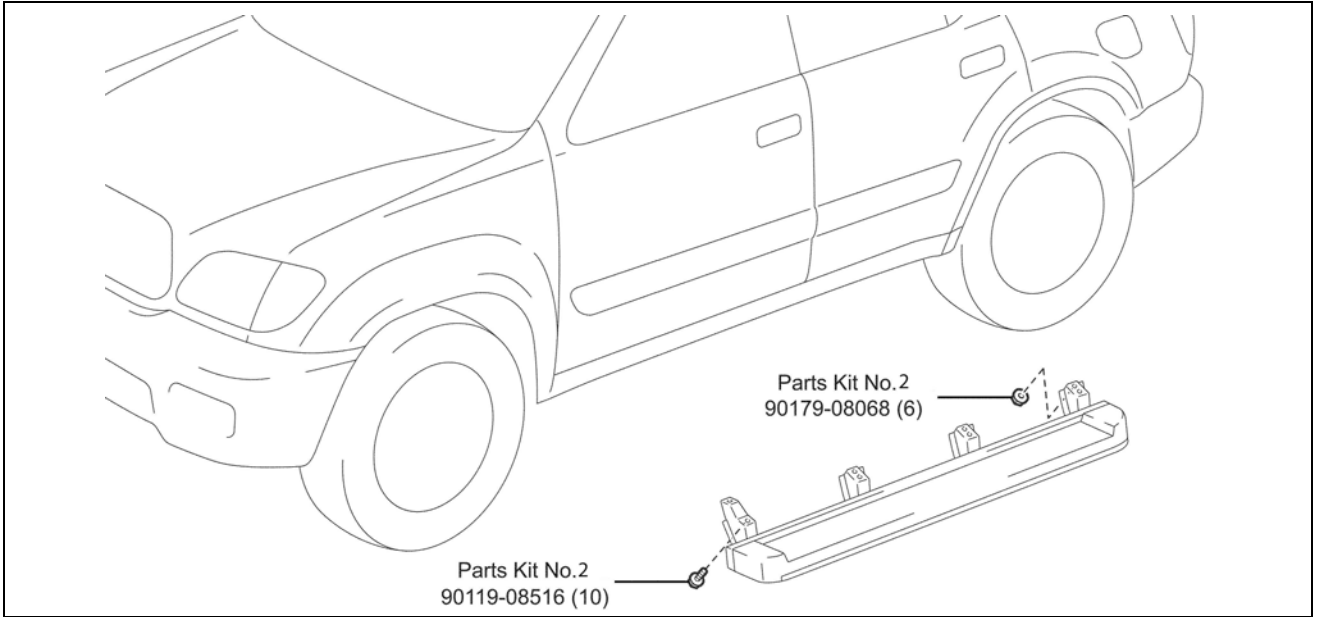

### III. FRAME INSPECTION

#### 1. PERFORM INITIAL PRE-HOIST INSPECTION

1. INSPECT THE FRAME FOR EXCESSIVE FRAME CORROSION THAT COULD AFFECT THE STRUCTURAL INTEGRITY OF THE FRAME

#### 2. FRAME INSPECTION



All frame inspection must be performed using the NEW frame inspection application on TIS. Ensure you inspect the frame and properly document the inspection. Failure to perform this will result in denial of the claim.

#### 1. ACCESS INSPECTION APPLICATION

- Run the VIN in TIS and click on the Warranty Tab
- Click on the “Frame Inspection” link on TIS

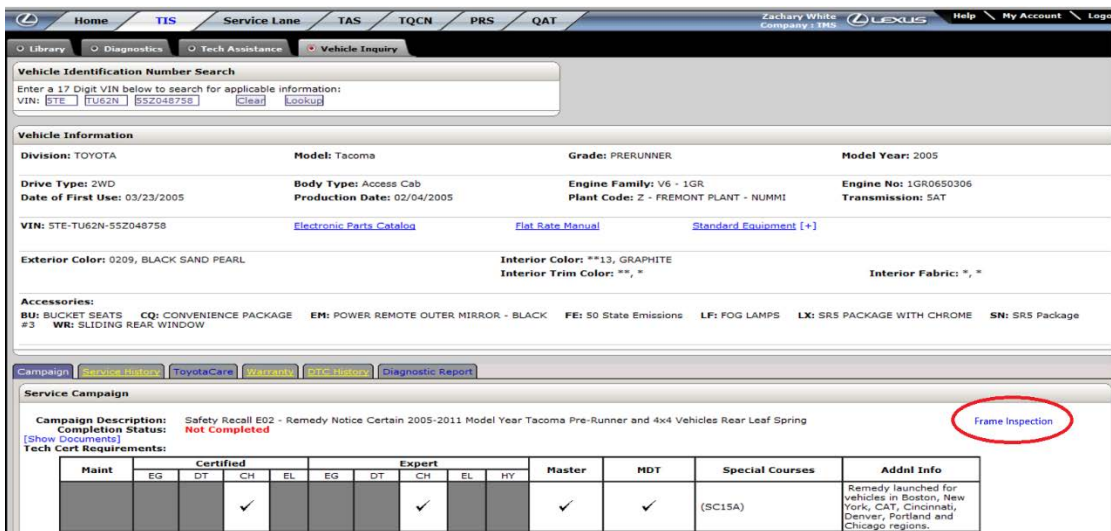

Vehicle Information

Division: TOYOTA	Model: Tacoma	Grade: PRERUNNER	Model Year: 2005
Drive Type: 2WD	Body Type: Access Cab	Engine Family: V6 - 1GR	Engine No: 1GR0650306
Date of First Use: 03/23/2005	Production Date: 02/04/2005	Plant Code: Z - FREMONT PLANT - NUMMI	Transmission: SAT

VIN: STE-TU62N-55Z048758

Exterior Color: 0209, BLACK SAND PEARL

Interior Color: \*\*13, GRAPHITE

Interior Trim Color: \*\*, \*

Interior Fabric: \*, \*

Accessories: BU: BUCKET SEATS CQ: CONVENIENCE PACKAGE EM: POWER REMOTE OUTER MIRROR - BLACK FE: 50 State Emissions LF: FOG LAMPS LX: SRS PACKAGE WITH CHROME SN: SRS Package #3 WR: SLIDING REAR WINDOW

Service Campaign

Campaign Description: Safety Recall E02 - Remedy Notice Certain 2005-2011 Model Year Tacoma Pre-Runner and 4x4 Vehicles Rear Leaf Spring

Completion Status: Not Completed

Tech Cert Requirements:

Maint	Certified				Expert				Master	MDT	Special Courses	Addnl Info
	EG	DT	CH	EL	EG	DT	CH	EL				
			✓				✓		✓	✓	(SC15A)	Remedy launched for vehicles in Boston, New York, CAT, Cincinnati, Denver, Portland and Chicago regions.

#### 2. LOG INTO THE INSPECTION APPLICATION

- Reenter your TIS password

### Frame Inspection

Language:  English  French  Spanish

Re-enter your TIS Password to proceed with the Frame Inspection.

Verify the User ID currently logged into TIS matches the technician's User ID performing the Frame Inspection.

TIS Password

### 3. ENTER VEHICLE INFORMATION

- Enter the vehicle mileage.
- Select the state from the drop-down menu that the vehicle is registered.

**Note: Do NOT select the state the dealership is located.**

- Inspect the frame for CRC compound that could have been previously applied:

**CRC was Previously Applied:** Select the CRC Bottle Button

**NO CRC Previously Applied:** Select Frame Button



**Note: CRC could only be previously applied to 2005 to 2008 Tacoma vehicles.**

**Frame Inspection Home**

User ID : 406218      Technician Name : John  
Dealer Code :      Dealer Name :  
Date / Time : 05/10/2016 01:41 PM PDT      VIN :  
DMY : Toyota Highlander 2015

Vehicle Mileage:  Miles      Vehicle Registered State:

[Has the vehicle had CRC previously applied to the frame?](#)  
[Click on the appropriate icon below to start the Frame Inspection process.](#)

      

### 4. INSPECT THE FRAME SECTIONS

- Inspect the frame in the colored areas below and use the application to document the results of the inspection.

**Note: Crossmember mounting locations should be inspected 6" into the crossmember.**

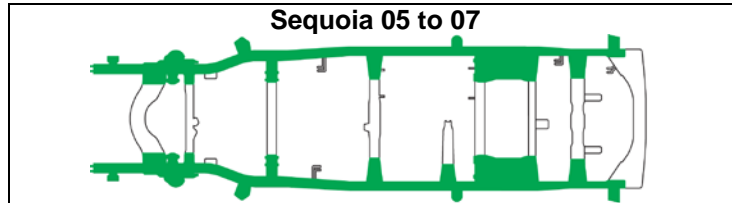

- Select Section A

**Note: The frame inspection application must be completed in alphabetical order.**

[Click on the highlighted section of the frame diagram below to start the inspection process.](#)

[Each section of the frame must be inspected as instructed by the Technical Instructions.](#)

[You must start in Section A \(Front Passenger Side of the vehicle\) and proceed to each section in alphabetical order.](#)

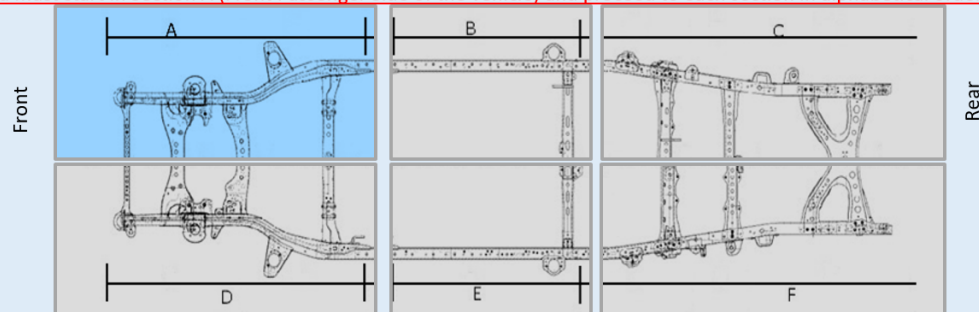

- c. Inspect the frame section and inspect all surfaces of the frame rail and crossmember. Select the photo that best represents the frame condition. If perforation of 10mm or larger is identified select "Peroration of the Frame".

**Note: You must click the bubble next to the image to select the condition.**

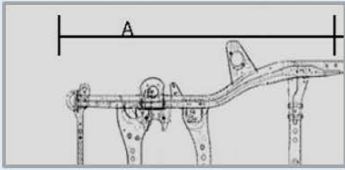





E-Coat Intact



Light to Moderate Surface Rust



Complete Surface Rust with Descaling



Perforation of the Frame

- d. If you selected Perforation of the Frame, the application will request more information about the size of perforation(s) and location.
- e. The section with perforation will split into 2 sub-sections to further identify the perforation location.
- f. Select the size of the perforation in each sub-section.
- g. Upload a photo for each area containing perforation and describe the location in the comments section.

**Note:**

- **Include the R.O. in the image of at least one of the perforation holes.**
- **If both sub-sections have perforation, it will require two pictures to be uploaded.**
- **If perforation was accidentally selected use the back button to reselect the correct frame condition.**

- h. Select Next to move onto the next section.

**Frame Inspection**

**Select Perforation Identification - NO CRC Applied**

The frame section has been split into two smaller sections to help clarify to the technical staff where the perforation is located. Please select the location and size of the perforation and upload an image of the perforation.

Note: If perforation is found in both areas please identify both perforation locations below.

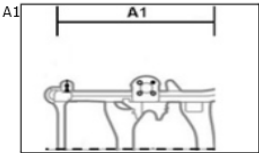
A1 

A1 Check the appropriate perforation size\*

Perforation Found during Frame Clearing for CRC-10mm and above

16mm or above

10 to 15mm

None

Comments: (500 Chars)

IMG\_1302.JPG 

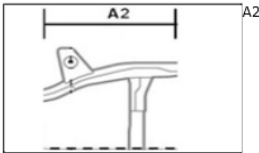
A2 

A2 Check the appropriate perforation size\*

Perforation Found during Frame Clearing for CRC-10mm and above

16mm or above

10 to 15mm

None

Comments: (500 Chars)

- i. Once all sections have been completed, select the Submit button.

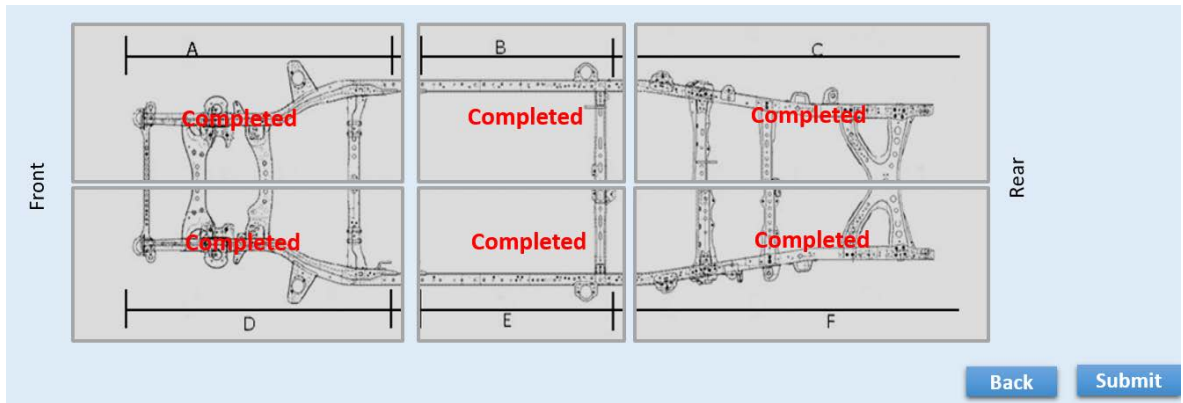

#### NO Perforation Found

- j. If no perforation was not found, follow the directions as provided.

[Frame Inspection Case: FI000000001](#)  
[Inspection Summary: No Perforation Found](#)

[The frame inspection has been completed successfully. Please print a copy of the inspection case and file it with the R.O. for warranty claim filing.](#)

#### Perforation Found

- k. If perforation was found, this application will be submitted to your Regional Office for review. The region office will review the inspection and provide feedback if the frame replacement is approved for future repair.



**DO NOT proceed with frame replacement or parts ordering until you are provided with approval from the Regional Office. Approval will be sent to the TIS inbox for the inspection, Service Manager and Parts Manager.**



**Frame Inspection**

**Frame Inspection - NO CRC Applied**

<b>User ID</b>	: JOHNSOJ459	<b>Technician Name</b>	: James Johnson
<b>Dealer Code</b>	: 54012	<b>Dealer Name</b>	: CYPRESS COLLEGE
<b>Date/Time</b>	: 07/08/2017 2:12 PM PDT	<b>VIN</b>	: 5TBRT38101S125908
		<b>DMY</b>	: TOYOTA Tundra 2001
<b>Vehicle Mileage</b>	:* 120568 Miles	<b>Vehicle Registered State</b>	:* VT <input type="text"/>

Frame Inspection Case: FI0000000881  
Inspection Summary: Perforation has been found in Sections A1,C1,C2.  
Toyota Technical Staff will review and provide feedback or authorization for repair.  
Feedback and authorization will be sent to your TIS Inbox when the review has been completed.

[Close](#)

## IV. FRAME REPLACEMENT WORK PROCEDURE

### A. PERFORM PRELIMINARY VEHICLE INSPECTION

1. Perform health check and record any preexisting DTCs
2. Test drive the vehicle and inspect the following vehicle functions/current operating conditions prior to vehicle repair.
  - 4WD System (*4WD Only*)
  - Interior Lights
  - Exterior Lights
  - HVAC System
  - Audio System
  - Power Windows
  - Power Door Locks
  - All Gauges, Indicators and Warning Lights
  - Cooling Fans
  - Etc.
3. Documents the current vehicle operating condition on the [Frame Replacement Inspection Sheet](#).

### B. SAFETY CHECKLIST & PRECAUTIONS WHEN DRAINING THE FUEL SYSTEM



- Always remember **"SAFETY FIRST"**.
- Be extremely careful when handling fuel to prevent fires from occurring.
- Before beginning work on the fuel system, perform the following safety check list.
- Before removing any fuel system part, drain all fuel to prevent spilling.

#### 1. AIR VENTILATION

- Perform work in a well-ventilated area.
- DO NOT** work underground or in an area where fuel vapors may fill the room due to poor ventilation.
- Quickly clean up any spilled fuel with a dry cloth and dissipate the fuel vapors.
- Dry all cloths that have come in contact with fuel in a well-ventilated area and dispose of them properly (according to applicable local regulations).

#### 2. FIRES AND IGNITION SOURCES ARE STRICTLY PROHIBITED

- Fires and ignition sources are prohibited while working on the fuel system.
- Clearly display the sign found on the next page stating **"WORKING WITH GASOLINE, NO FIRES OR IGNITION SOURCES"**.
- Smoking is prohibited near the work area.
- DO NOT** work in areas where there are welders, grinders, drills, electric motors, heaters, etc.
- DO NOT** use work lamps or any other electrical appliance due to the risk of sparks flying from the power switch or a rise in temperature.
- DO NOT** use metal hammers while working, due to the risk of flying sparks.
- DO NOT** start any engines or perform any of the above in neighboring work bays.

#### 3. FIRE EXTINGUISHER

- Have a fire extinguisher ready and available before beginning work.

#### 4. PREVENT STATIC ELECTRICITY

- To help prevent static electricity, lightly wet the floor with water, but not to the point where it creates a hazardous working condition.
- Place appropriate warning cones or stand signs around the area as a caution.

#### 5. PRECAUTIONS WHEN USING A LIFT

- For bays equipped with auto lifts, cover all access cover joints with duct tape.
- In the event that fuel has leaked inside the auto lift, remove the access cover and clean up any spilled fuel. Dissipate fuel vapors until the smell is gone.

#### 6. PREVENT THE FUEL FROM SPRAYING

- When disconnecting any fuel tubes, pipes, hoses or connectors there may still be some pressure remaining, even after discharging the system. To prevent the fuel from spraying, cover the tubes, pipes or connectors with a shop rag before disconnecting.
- Remember to always wear protective goggles especially when disconnecting fuel tubes, pipes, hoses or connectors.

#### 7. PREVENT THE FUEL FROM CONTACTING OTHER PARTS

- Do not allow the fuel to come in contact with any parts made of rubber or leather.

#### 8. ASSIGN A SAFETY SUPERVISOR

- Assign a safety supervisor to be in charge of all safety precautions and fire hazards around the work area.

■ Copy And Display When Working

**WORKING WITH  
GASOLINE**

**NO FIRES  
NO IGNITION  
SOURCES**

Supervisor



■ Copiar y exhibir al trabajar

**TRABAJANDO CON  
GASOLINA**

**NINGÚN INCENDIOS**

**NINGUNA FUENTE  
DE IGNICIÓN**

Supervisor



- The actual vehicle specs, equipment and parts required may differ than what is shown. Please use the correct specs and parts for the model you are working on.
- For additional repair information, please reference to the appropriate repair manual.
- **DO NOT** disconnect any part of the fuel system until you have discharged the fuel pressure.
- Even after discharging the fuel pressure, place a piece of cloth around the lines, pipe, hoses, and connectors as you separate them to reduce the risk of fuel spraying on yourself, in the engine compartment, and onto other parts.
- Before commencing the operation, set the vehicle in the center of a lift, stop it in a position where all the doors can be opened, and center the steering wheel so that the front wheels are in a straight-ahead position.

### 1. CHECK FOR DTCs TO ENSURE VEHICLE ORIGINAL OPERATING CONDITION

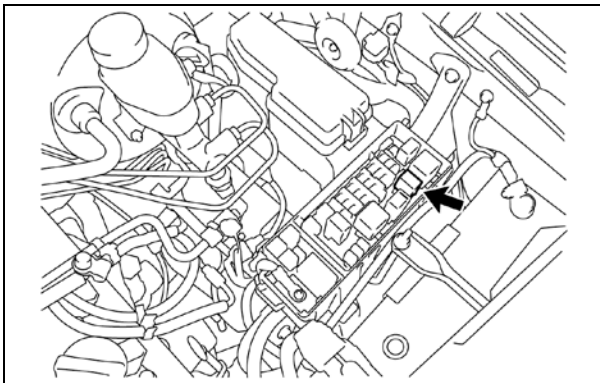

### 2. REMOVE THE FUEL PUMP RELAY

- a) Remove the junction block cover.
- b) Remove the fuel pump relay.

### 3. DISCHARGE THE FUEL SYSTEM PRESSURE

- a) Start the engine.
- b) After the engine has stopped, turn the ignition switch OFF.
- c) Crank the engine again to check that it does not start.

**NOTE:** Make sure to follow the procedure listed above, this prevents a large amount of gasoline from leaking out of the high pressure fuel line when it is disconnected.

### 4. EVACUATE THE A/C REFRIGERANT

### C. PREPERATION FOR REMOVAL OF THE BODY ASSY

1. RECORD THE RADIO STATION PRESETS
2. DISCONNECT THE NEGATIVE (-) BATTERY TERMINAL CABLE

**Note:** if the vehicle is equipped with power seats, you will need to access the front passenger seat bolts prior to disconnecting the battery in order to remove the seat to access the chassis wire.



- Wait at least 90 seconds after disconnecting the negative (-) battery terminal from the battery to prevent the SRS System from deploying (i.e. airbag, seat belt pretensioner, etc.).

3. REMOVE THE FOLLOWING INTERIOR PARTS TO ACCESS WIREHARNESS CONNECTORS & CAB MOUNTING BOLTS

- Front Door Scuff Plate LH/RH
- Cowl Side Trim Board LH/RH
- Passenger Front Seat
- Glove Compartment Door
- Lower No.2 Instrument Finish Panel
- No.4 Heater To Register Duct



- The actual vehicle specs, equipment and parts required may differ than what is shown. Please use the correct specs and parts for the model you are working on.
- For additional repair information, please reference to the appropriate repair manual.

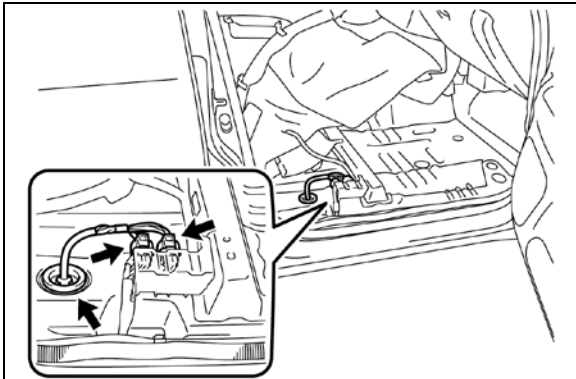

4. DISCONNECT THE FRAME WIRE CONNECTORS

- a) Fold back the floor carpet and disconnect the 2 connectors.
- b) Disconnect the frame wire harness grommet.
- c) Pull out the frame wire harness from the vehicle cab.

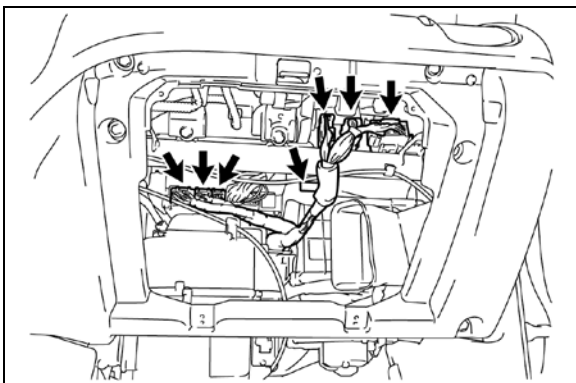

5. DISCONNECT THE ENGINE WIRE HARNESS

- a) Disconnect the 6 connectors and clamp.

**NOTE:** The number of connectors will differ depending on the vehicle specs.

## 6. REMOVE THE FOLLOWING PARTS FROM THE CENTER CONSOLE AREA (4WD Only)

- Transfer Shift Lever Knob
- Shifting Hole Cover
- Upper Console Panel
- No.1 Shift and Select Lever Boot
- Transfer High and Low Shift Lever

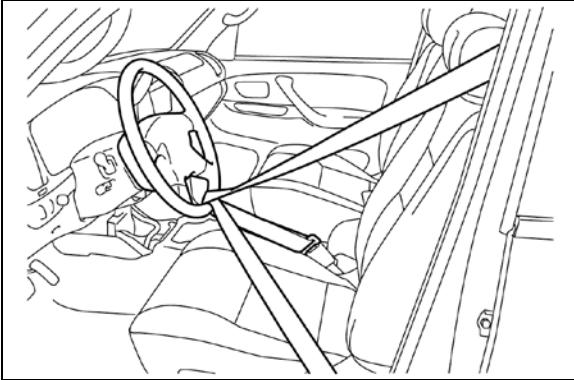

## 7. SECURE THE STEERING WHEEL

- a) Make sure the front wheels are in a straight-ahead position and the steering wheel is centered.
- b) Using the seat belt, hold the steering wheel in position as shown in the illustration, in order to prevent damage to the spiral cable.

## 8. FOLD UP THE 2<sup>nd</sup> ROW SEATS AND REMOVE REAR PASSENGER DOOR SCUFF PLATES

## 9. REMOVE THE FOLLOWING INTERIOR COMPONENTS TO ACCESS CAB MOUNTING BOLTS

- 2<sup>nd</sup> Row Seat Outer Belt Floor Anchor
- 3<sup>rd</sup> Row Seats (*If Equipped*)
- 3<sup>rd</sup> Row Seats Outer Belt Floor Anchors (*If Equipped*)
- Rear Floor Mat Support Plate
- Rear Quarter Trim Panel LH/RH



- Place jack stands under the front and rear portions of the frame to support the frame.
- DO NOT work directly underneath vehicle when preparing the vehicle for cab body assy removal, unless noted.
- The actual vehicle specs, equipment and parts required may differ than what is shown. Please use the correct specs and parts for the model you are working on.
- For additional repair information, please reference to the appropriate repair manual for the vehicle you are working on.

## 10. LIFT VEHICLE ON LIFT

## 11. REMOVE THE FOLLOWING PARTS UNDER VEHICLE COMPONENTS

- No.1 Engine Under Cover
- Side Step Assy LH/RH (if applicable)

## 12. DRAIN THE FOLLOWING FLUIDS

- Engine Coolant (including the engine block)
- Brake Fluid
- Front Differential Oil (4WD ONLY)

**Note:** DO NOT remove the radiator cap while the radiator and engine are hot, as doing so may cause the coolant to spray out causing potential injuries.

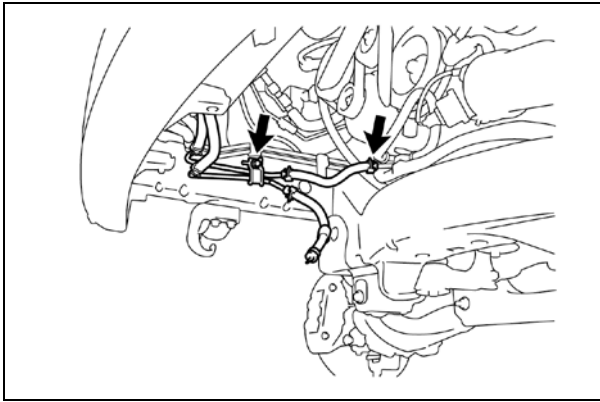

**13. DISCONNECT THE AUTOMATIC TRANSMISSION NO.2 OIL COOLER OUTLET TUBE**

- a) Disconnect the hose.
- b) Remove the bolt and disconnect the No.2 oil cooler outlet tube.

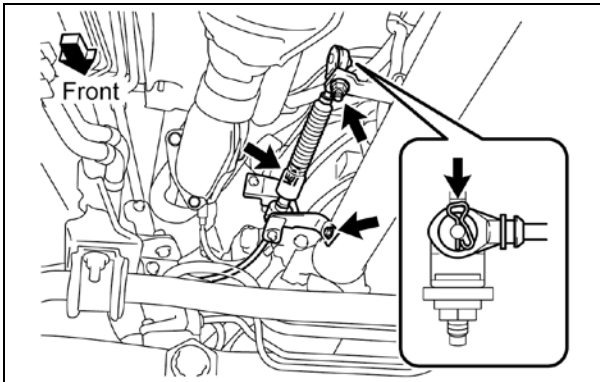

- a) Remove the pin and washer.
- b) Remove the 2 bolts and disconnect the transmission control cable.

**NOTE: If the pin is difficult to remove, remove the nut and then the cable.**

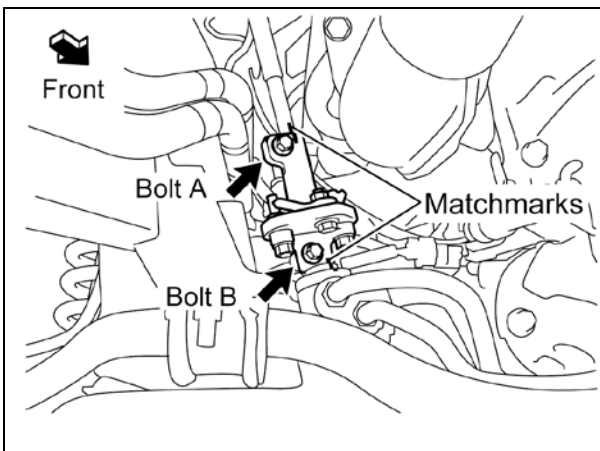

**14. REMOVE THE NO. 2 STEERING INTERMEDIATE SHAFT**

**NOTE:**

**Use precaution when performing this step, as you will need to work underneath the vehicle.**

- a) Place match marks on the steering sliding yoke and No.2 steering intermediate shaft.
- b) Loosen the bolt (A) and remove the bolt (B).
- c) Disconnect the steering sliding yoke from the No.2 steering intermediate shaft.

**NOTE: If the No. 2 intermediate shaft assy. is stuck, tap it from below with a brass hammer to disconnect it.**

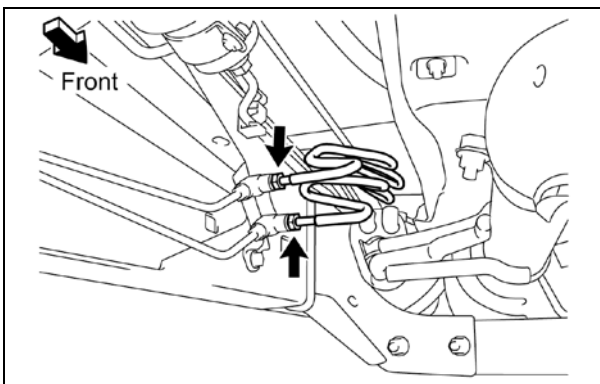

**15. DISCONNECT THE REAR BRAKE TUBES**

- a) Using a flare nut wrench, disconnect the 2 rear brake tubes.

**NOTE: Use precaution when performing this step, as you will need to work underneath the vehicle.**

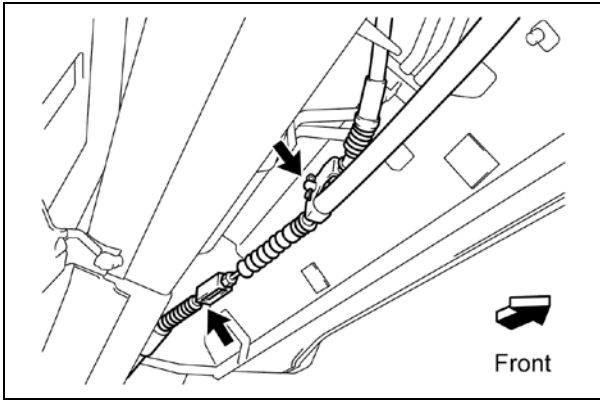

## 16. DISCONNECT THE PARKING BRAKE CABLES

- a) Disconnect the No.1 parking brake cable from the No.3 parking brake cable.
- b) Remove the clip and pin and disconnect the No.2 parking brake cable.

**NOTE: Use precaution when performing this step, as you will need to work underneath the vehicle.**

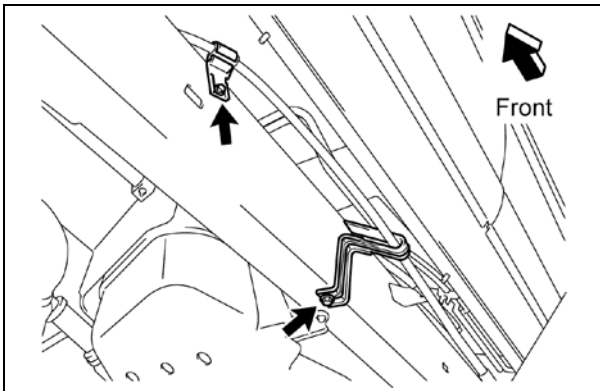

- c) Remove the bolt and cable support bracket from LH side frame rail.
- d) Remove the bolt and disconnect the No.1 parking brake cable from LH side frame rail.

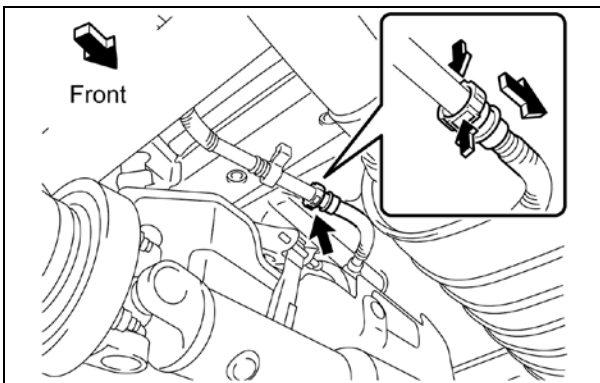

## 17. DISCONNECT THE FUEL TANK VENT HOSE

**NOTE: Use precaution when performing this step, as you will need to work underneath the vehicle.**

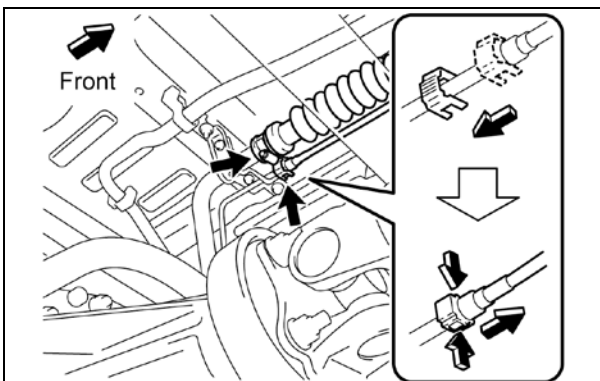

## 18. DISCONNECT THE FUEL TANK TO FILLER PIPE HOSE AND FUEL TANK BREATHER HOSE

**NOTE: Use precaution when performing this step, as you will need to work underneath the vehicle.**

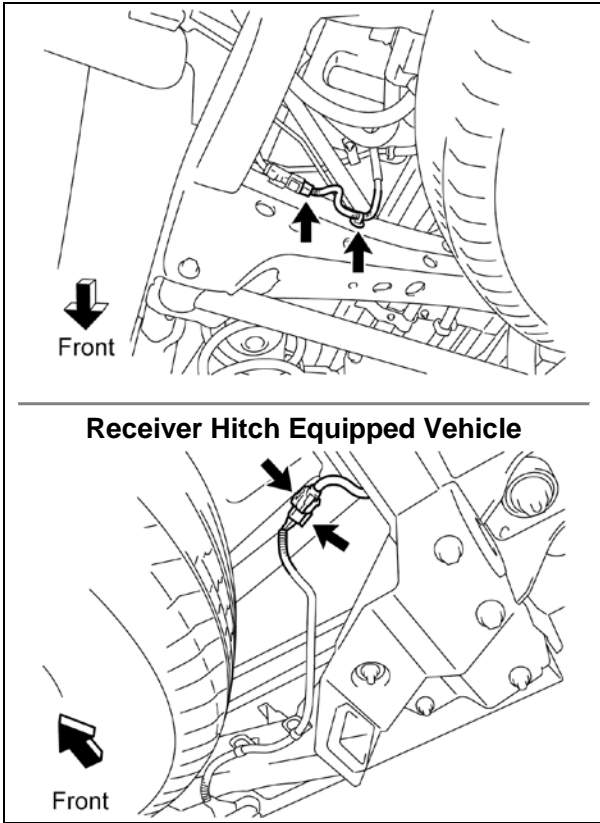

## 19. DISCONNECT THE FRAME WIRE

**NOTE:** Use precaution when performing this step, as you will need to work underneath the vehicle.

- a) Disconnect the connector for charcoal canister and clamp(s).
- b) Disconnect the connector(s) and clamp(s) for the receiver hitch.

*(Receiver Hitch Equipped Vehicle Only)*

**NOTE:** The number of fastening connectors and clamps for the frame wire will differ depending on the vehicle options. Please verify the current vehicle options and continue.

## 20. REMOVE THE FOLLOWING FRONT END COMPONENTS

- Front Fender Mudguard LH/RH
- Front Bumper Assy
- Front Bumper Energy Absorber

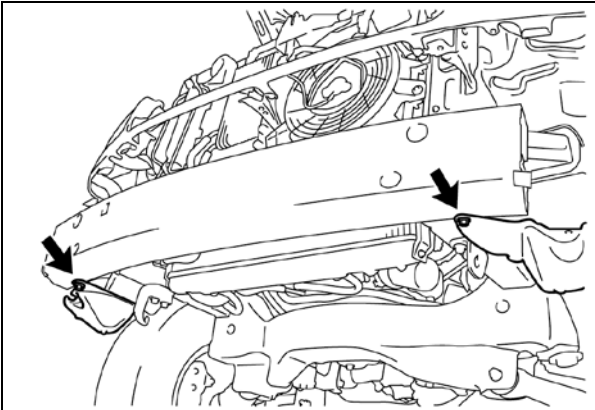

## 21. DISCONNECT THE FRONT FENDER LINERS

- a) Remove the 2 screws and disconnect the front fender liners from the front bumper reinforcement.

LH Side

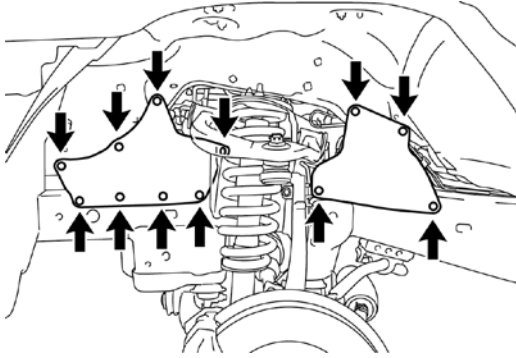

## 22. REMOVE THE FRONT FENDER APRON SEALS

- a) Remove the 21 clips and 4 front fender apron seals.

RH Side

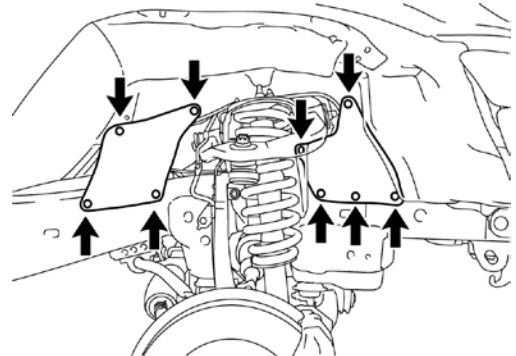



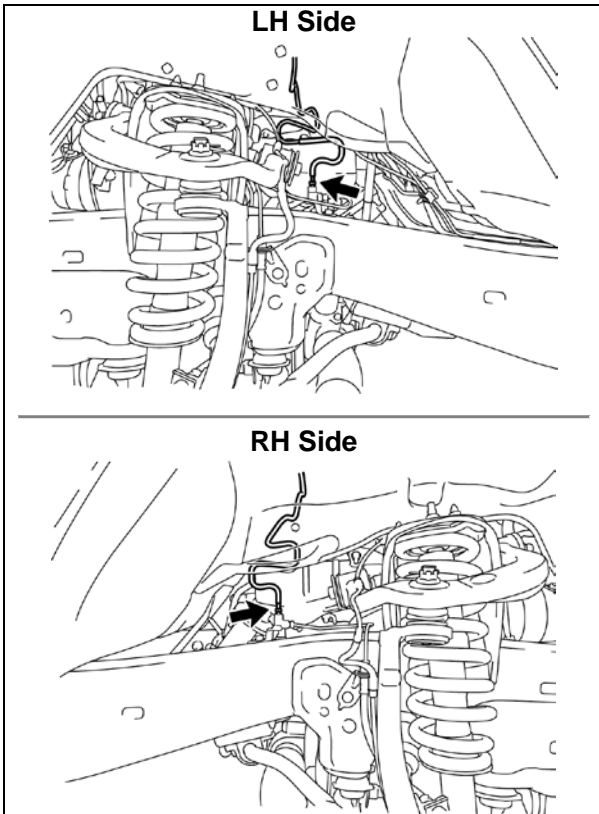

### 23. DISCONNECT THE FRONT BRAKE TUBES

- a) Disconnect the front brake tube.

**Note: Seal off the front brake lines to ensure no rust and debris enters the brake system.**

- b) Repeat the procedure on the opposite side.

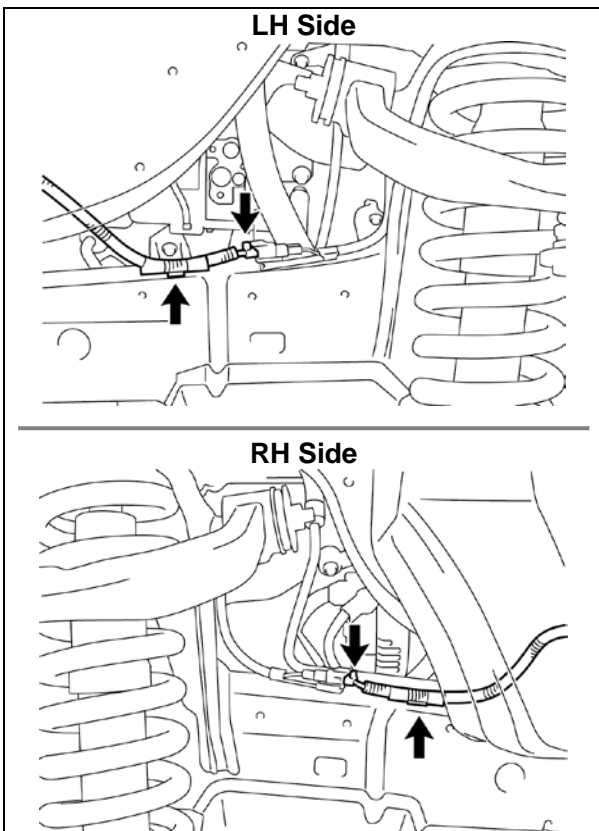

### 24. DISCONNECT THE FRONT SPEED SENSOR CONNECTORS

- a) Disconnect the clamp and front speed sensor connector.

- b) Repeat the procedure on the opposite side.

### 25. REMOVE THE FOLLOWING PARTS

- Rear Quarter Panel Mudguard LH/RH
- Rear Bumper Assy.

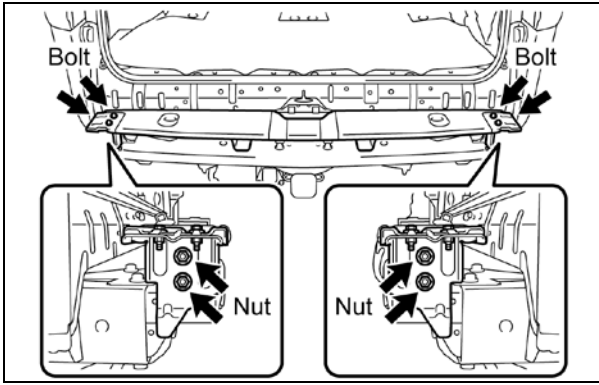

**26. REMOVE THE REAR BUMPER EXTENSION MOUNTING BRACKET W/ BACK STEP REINFORCEMENT**

- a) Loosen the 4 bolts.
- b) Remove the 4 nuts and the rear bumper extension mounting bracket w/ back step reinforcement.

**27. REMOVE/DISCONNECT THE FOLLOWING PARTS FROM ENGINE COMPARTMENT AREA**

- Throttle Body Cover
- Air Cleaner
- Radiator Inlet Hose (disconnect from engine)
- Radiator Outlet Hose (disconnect from engine)
- Disconnect Heater Coolant Hose
- Fan Shroud
- External Trans Cooler (If Equipped)
- Radiator Assy

**NOTE: After disconnecting the automatic transmission oil cooler hoses, plug them and cap the fittings to prevent the ATF from spilling out.**

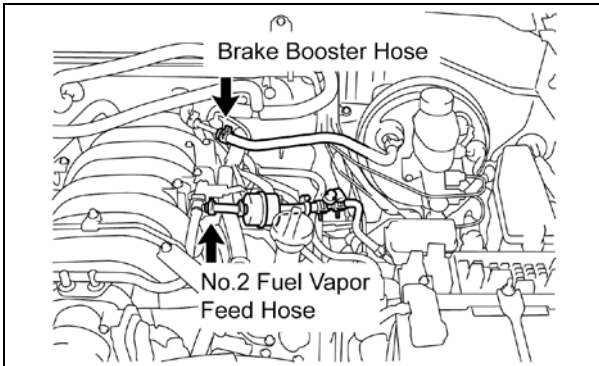

**28. DISCONNECT THE FOLLOWING ENGINE COMPARTMENT HOSES**

- a) Disconnect the brake booster hose.
- b) Disconnect the No.2 fuel vapor feed hose.

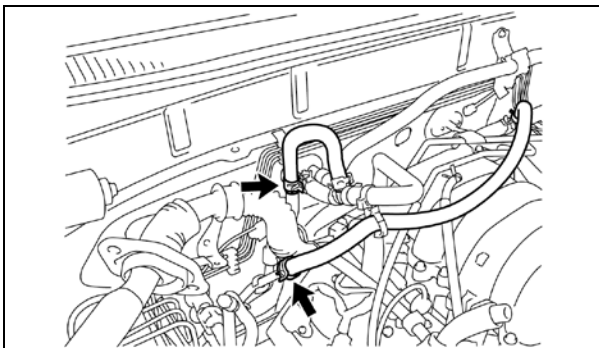

**29. DISCONNECT THE REAR HEATER WATER HOSES (IF EQUIPPED)**

- a) Disconnect the 2 rear heater water hoses from the water pipe.

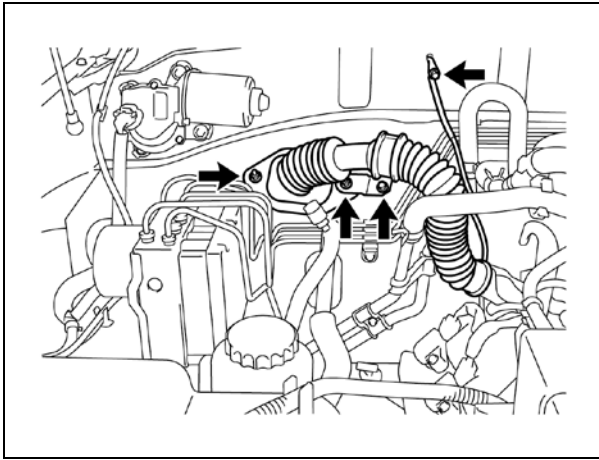

### 30. DISCONNECT THE ENGINE WIRE HARNESS

- a) Remove the bolt and disconnect the ground wire from cowl panel.
- b) Remove the bolt and the 2 nuts holding the engine wire harness connector from the cowl panel.
- c) Gently pull the engine wire harness out from body assembly.

**Note: Ensure all connectors have been previously disconnected from the glove compartment to ensure you do not damage the wire harness**

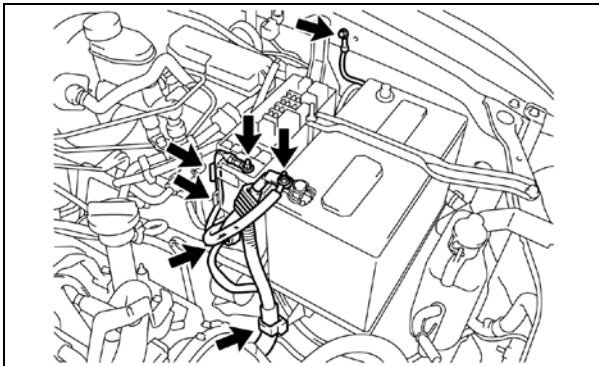

### 31. DISCONNECT THE NO.2 ENGINE WIRE HARNESS

- a) Disconnect the connector and clamp from inner LH front fender.
- b) Remove the bolt and disconnect the ground wire.
- c) Remove the nut and disconnect the positive (+) battery cable.
- d) Remove the nut and 2 clamps and disconnect the No.2 engine wire harness from the junction block.

### 32. DISCONNECT THE A/C DISCHARGE HOSE AND SUCTION HOSE

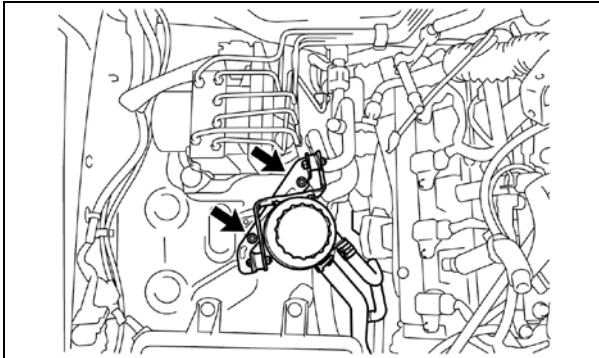

### 33. DISCONNECT THE POWER STEERING PUMP OIL RESERVOIR

- a) Remove the 2 nuts and place the power steering reservoir on the engine assembly.

## D. REMOVAL OF THE BODY ASSY

---

### 34. REMOVE THE CAB BODY ASSY USING AN ABOVE GROUND LIFT

**Note:** Before rolling chassis out, mark the location of the tires on the floor, this will help align the chassis when the cab is reinstalled.

- a) Remove the 8 nuts and 8 washers.
- b) Set the lift arms under the cab body assy. so they **DO NOT** interfere with the frame or cab mounts.
- c) Check that all wire harnesses, hoses, cables and the steering shaft are disconnected.
- d) Lift the cab assy. up slowly, making sure it does not interfere with anything while being raised.
- e) Raise the cab assy high enough so that the top of the engine clears the lowest point of the cab assy.
- f) Pull the frame assy out from under the cab assembly.
- g) Lower the cab assy all the way down and leave it on the lift.

**NOTE:**

- Center the cab assy weight on the lift arms so that it does not slant/tilt to one side.
- Raise the cab assy slightly off the frame and verify that it is held securely by the lift arms.
- **DO NOT** work directly underneath the vehicle when pulling the frame assy. out from under it.
- **DO NOT** remove the cab mount bolts, as they will be used as guides during the cab assy. reinstallation process.

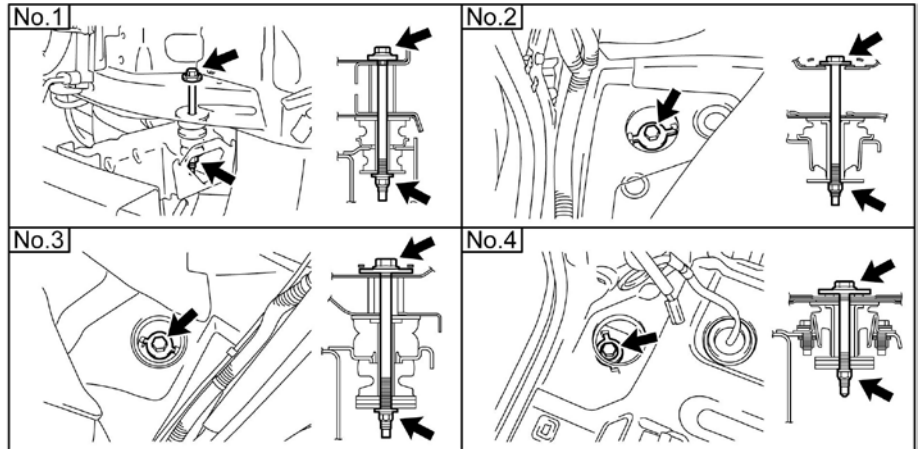
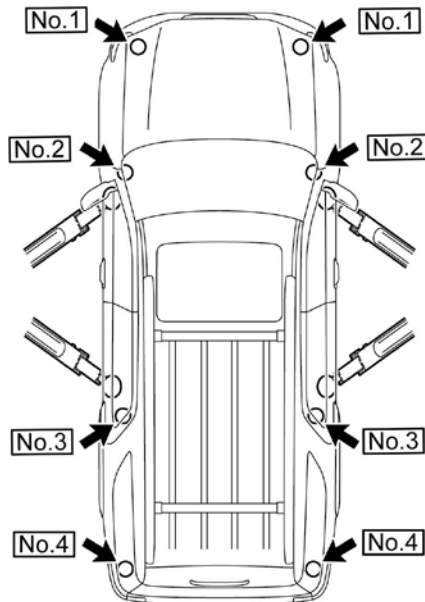

## E. DISASSEMBLE THE FRAME

### 1. PLACE THE FRAME ON A 2<sup>nd</sup> LIFT

a) Place the frame on the 2<sup>nd</sup> lift, and secure it with a ratcheting tie down strap. This will prevent the frame from tilting or falling off as parts are removed.

- **Ratcheting Tie Down: Qty: 1**
  - **Dimensions: 2 in X 27 ft**
  - **Minimum Work Load Capacity: 3,000 lbs**

### 2. REMOVE THE FOLLOWING PARTS

- Spare Tire Carrier
- Receiver Hitch Bracket Assy (*If Equipped*)
- Front Propeller Shaft (*4WD Only*)
- Rear Propeller Shaft
  - Insert the SST into the transmission after the rear propeller shaft is removed to prevent oil leakage.  
**(2WD Only)**
  - **SST: 09325-40010**
- No.1 Fuel Tank Protector
- Fuel Tank Straps
- Fuel Tank

#### NOTE:

**Make sure to place matchmarks on the front (if equipped) and rear propeller shafts before removal.**

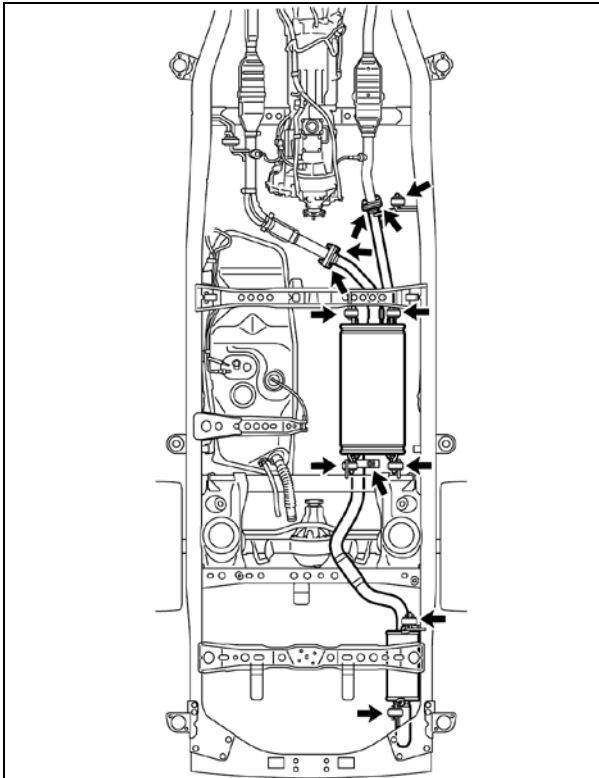

### 3. REMOVE THE EXHAUST SYSTEM

- a) Remove the clamp, 2 rear tail pipe brackets and rear tail pipe.
- b) Remove the 4 bolts, 4 exhaust pipe supports and center exhaust pipe.
- c) Remove the 3 exhaust pipe gaskets.

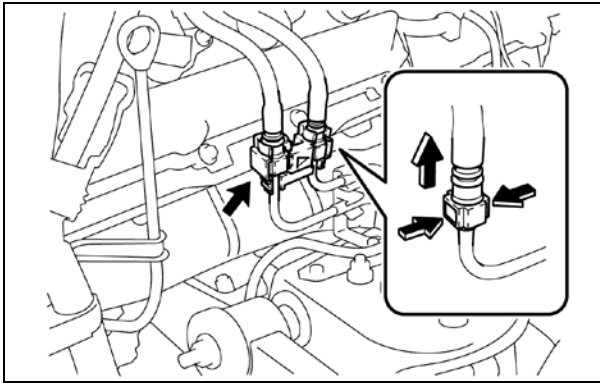

**4. DISCONNECT THE FUEL PIPE AND HOSE**

- a) Remove the No.1 fuel pipe clamp.
- b) Disconnect the 2 fuel pipes.

**NOTE:**

- Put a shop towel under the delivery pipe.
- Slowly loosen the pulsation damper.

**5. REMOVE THE DRIVE BELT**

**6. REMOVE AND SET A SIDE THE POWER STEERING PUMP ASSY**

- a) Remove the 2 bolts and nut and power steering vane pump assy.

**NOTE:**

- **DO NOT** disconnect the power steering pump hoses or lines.
- **Make sure to keep the power steering pump reservoir in an upright position to prevent the fluid from leaking out.**

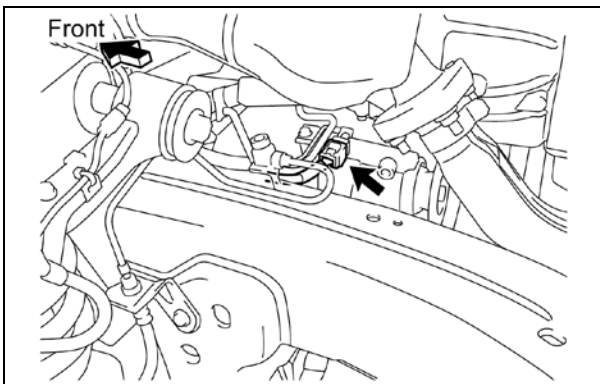

**7. DISCONNECT THE A.D.D. ACTUATOR CONNECTOR (4WD ONLY)**

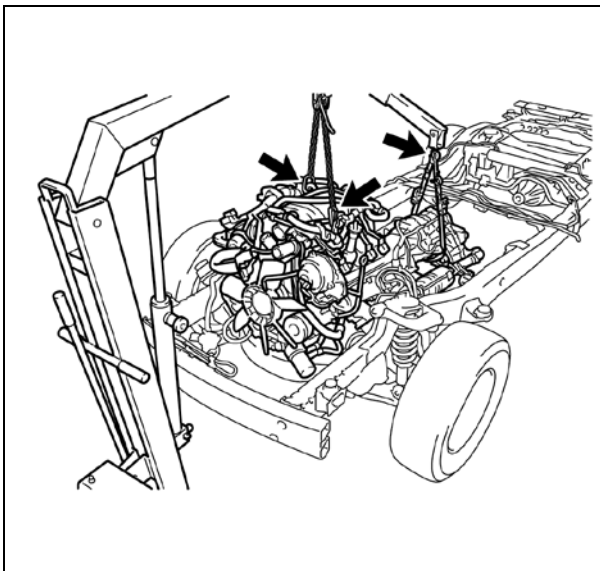

**8. REMOVE THE ENGINE AND TRANSMISSION ASSY.**

- a) Disconnect and remove the necessary items/parts to prepare the engine and transmission assy for removal.
- b) Remove the engine and transmission assy.

**NOTE:**

- **When removing the engine and transmission assy, ALWAYS use 2 engine hoists or mini cranes to lift it.**
- **DO NOT** use 1 engine hoist or mini crane to lift the engine and transmission assy, as the unbalanced weight may lead to an accident or injury.
- **ONLY** use engine hoists or mini cranes that can properly support the weight of the engine and transmission assy.
- **Carefully adjust the 2 engine hoists or mini cranes used so that the engine and transmission assy is properly balanced.**

**9. REMOVE THE 4 WHEELS**

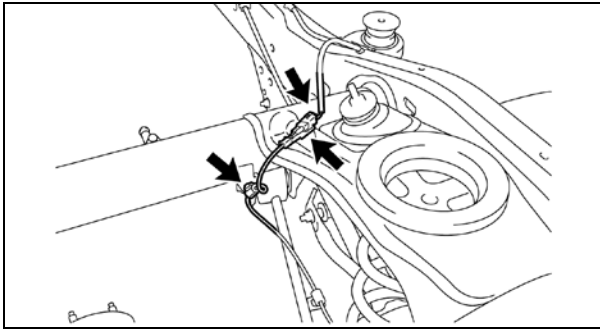

#### 10. DISCONNECT THE REAR SPEED SENSOR CONNECTOR

- a) Remove the 2 clamps and disconnect the rear speed sensor connector.
- b) Repeat the procedure on the opposite side.

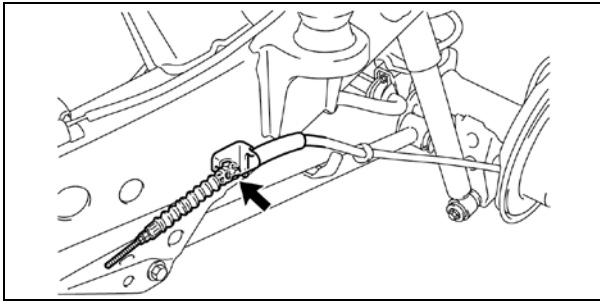

#### 11. DISCONNECT THE NO.3 PARKING BRAKE CABLE

- a) Remove the bolt and disconnect the No.3 parking brake cable.

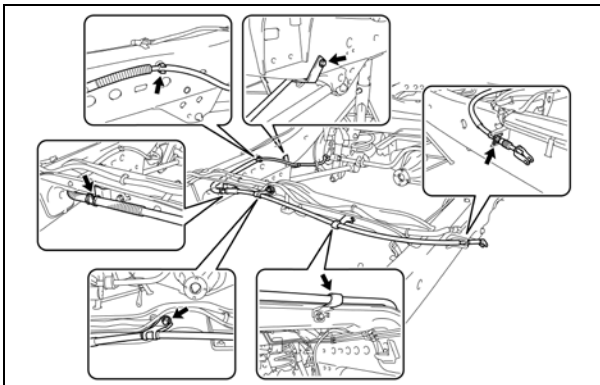

#### 12. REMOVE THE NO.2 PARKING BRAKE CABLE

- a) Remove the clip.
- b) Remove the 2 bolts.
- c) Disconnect the No.2 parking brake cable from the 3 clamps.

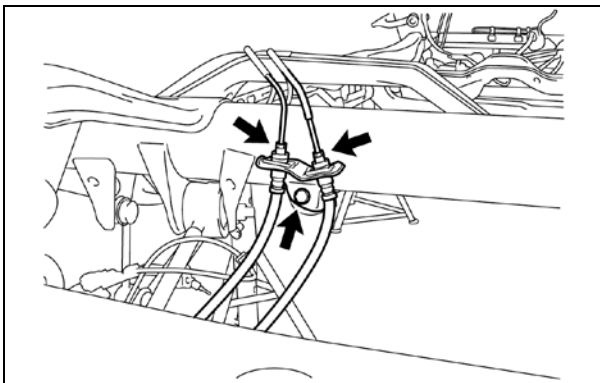

#### 13. DISCONNECT THE REAR BRAKE FLEXIBLE HOSES

- a) Using a flare nut wrench, disconnect the 2 rear brake tubes.
- b) Remove the bolt and disconnect the No.5 flexible hose bracket.

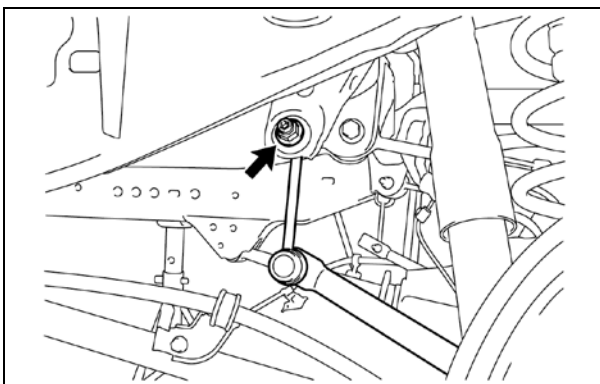

#### 14. DISCONNECT THE REAR STABILIZER BAR

- a) Remove the 2 nuts and disconnect the 2 rear stabilizer links from the frame.
- b) Remove the 4 bolts, 2 brackets and rear stabilizer bar.

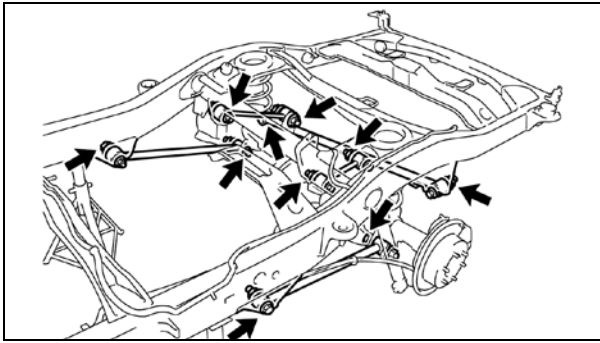

### 15. LOOSEN THE REAR SUSPENSION ARMS

- a) Loosen the bolts and nuts of the rear suspension arms, at the rear axle housing.
- b) Loosen the bolts and nuts of the rear suspension arms at the frame.

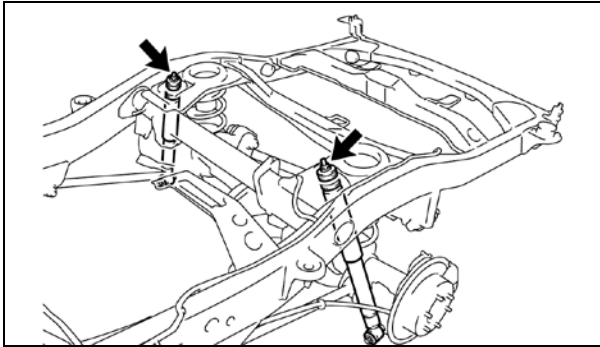

### 16. DISCONNECT THE REAR SHOCK ABSORBERS

- a) Using a floor jack raise the rear axle housing.
- b) Remove the 2 nuts and 2 retainers and disconnect the rear shock absorbers.

### 17. REMOVE THE REAR AXLE HOUSING W/ LINK ASSY

- a) Position the floor jack underneath the center section of the rear axle to support during the disassembly process.
- b) Remove the 2 bolts, washer, nut and the rear lateral control rod (Illustration A).
- c) Remove the 2 bolts, 2 washers and 2 nuts and disconnect the No.1 rear suspension arms from the frame (Illustration B).
- d) Slowly lower the jack, and remove the rear coil springs and hollow springs (Illustration C).
- e) Remove the 2 bolts, 2 washers and 2 nuts and disconnect the lower control arms from the frame (Illustration C).
- f) Roll the rear axle assembly away from frame.

Illustration A

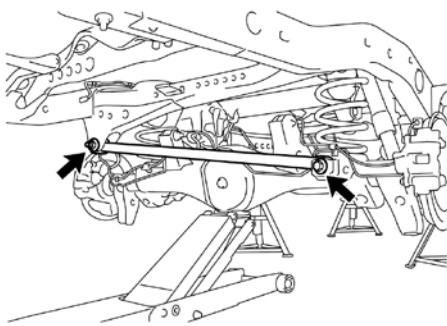

Illustration B

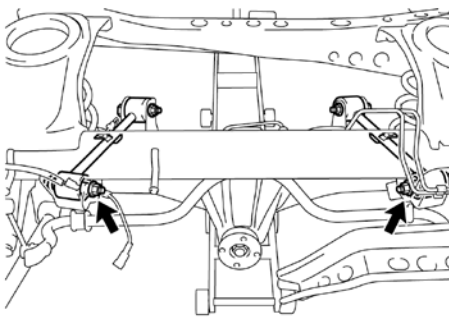
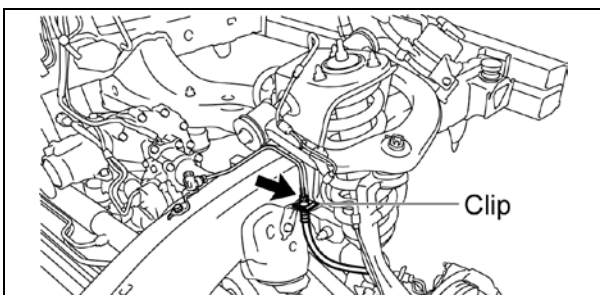
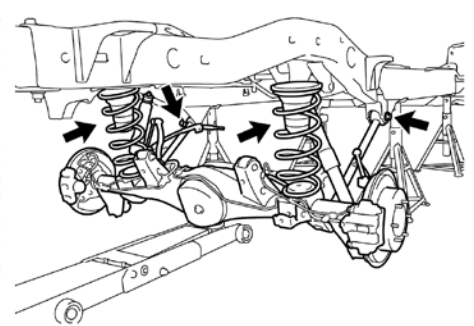

Illustration C



### 18. DISCONNECT THE NO.1 FRONT BRAKE FLEXIBLE HOSES

- a) Disconnect the front brake tube.
- b) Remove the clip and disconnect the No.1 flexible hose.
- c) Plug the hose to ensure not rust or debris enter the brake hose
- d) Repeat the procedure on the opposite side.



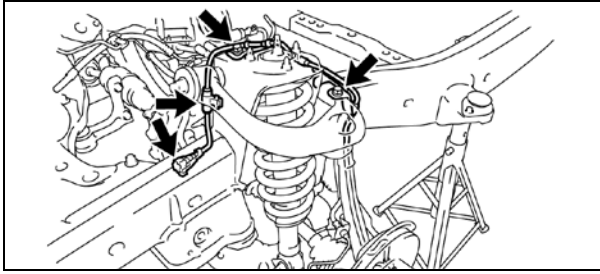

### 19. DISCONNECT THE FRONT SPEED SENSOR CONNECTORS

- a) Remove the 2 bolts and 2 clamps and disconnect the front speed sensor connector.
- b) Repeat the procedure on the opposite side.

### 20. REMOVE THE FOLLOWING FRONT END COMPONENTS

- Front Bumper Reinforcement
- Front Stabilizer Bar
- Front Axle Shaft Nuts (**4WD Only**)
- Tie Rod Ends
  - Remove the cotter pins and nuts.
  - Using the SST, disconnect the tie rod ends.
  - **SST: 09610-20012**
- Front Lower Ball Joints
  - Remove the cotter pins and nuts.
  - Using the SST, disconnect the lower ball joint.
  - **SST: 09628-62011**

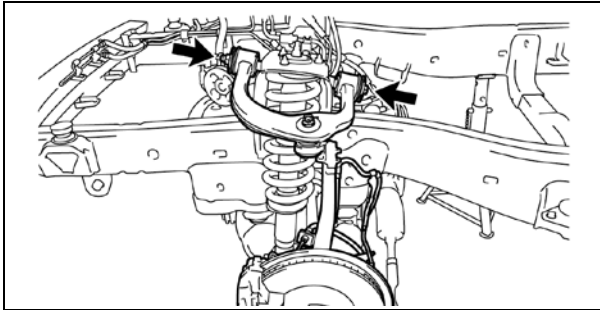

### 21. REMOVE THE FRONT SUSPENSION UPPER ARMS W/ STEERING KNUCKLE AND STRUT ASSY

- a) Remove the bolt, nut, 2 washers and front suspension upper arm w/ steering knuckle.
- b) Repeat the procedure on the opposite side.

**NOTE:**

If the drive shaft is difficult to disconnect, tap it loose with a plastic hammer.

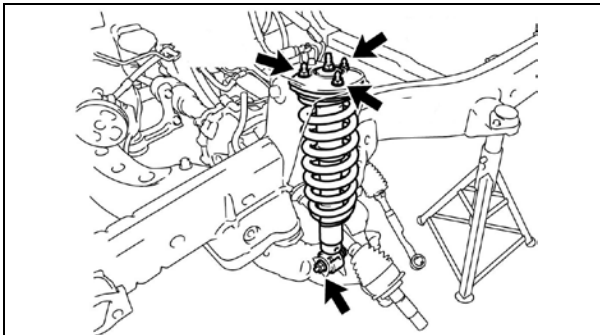

### 22. REMOVE FRONT STRUT ASSY AND LOWER CONTROL ARMS

- a) Remove Front Strut Assy by removing the three nuts and bolt.
- b) Repeat procedure on opposite side.
- c) Remove Front Suspension Lower Control Arm

### 23. REMOVE THE FOLLOWING POWERTRAIN COMPONENTS

- Power Steering Gear Assy w/ Power Steering Vane Pump
- Front Drive Shafts (**4WD Only**)
  - Using the SST, remove the drive shafts.
  - **SST: 09520-01010, 09520-32040**
- Front Differential Carrier (**4WD Only**)

**NOTE:**

- When removing the power steering rack with the pump assy attached, have one person support the power steering rack and the other support the pump assy.
- Keep the power steering pump reservoir in an upright position to prevent fluid from leaking out.
- If the drive shaft is difficult to remove tap it with a plastic hammer.
- Be careful not to damage the dust cover and oil seal.

## 24. REMOVE THE FOLLOWING PARTS

- Height Control Compressor Cover (*w/ Air Suspension*)
  - Height Control Compressor Assy (*w/ Air Suspension*)
  - No.2 Height Control Valve Sub-Assy (*w/ Air Suspension*)
- Height Control Tubes and Way (*w/ Air Suspension*)

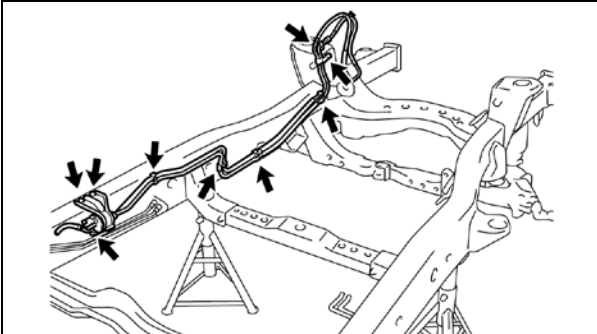

## 25. REMOVE THE FUEL TUBES

- a) Remove the bolts and clamps and the fuel tubes.

### NOTE:

- The number of fastening clips and clamps for the fuel tubes will differ depending on the vehicle model. Please verify the current vehicle and continue.

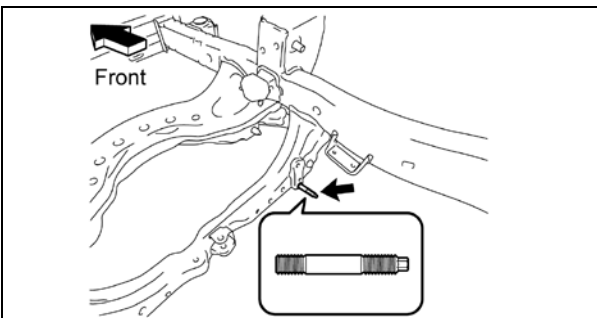

## 26. REMOVE THE STUD BOLT

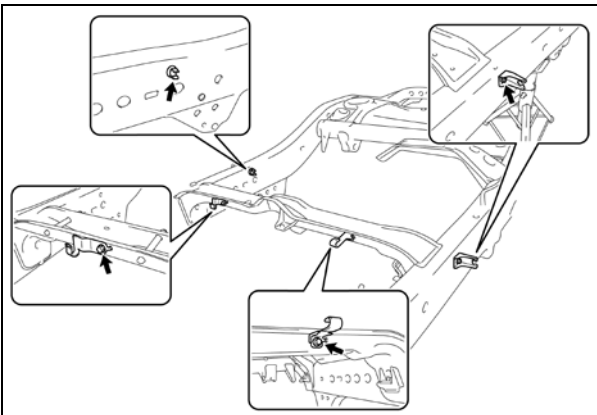

## 27. REMOVE THE FRONT PARKING BRAKE CABLE RETAINER BRACKET AND CLAMPS

- a) Remove the bolt and the front cable retainer bracket from crossmember.
- b) Remove the 2 bolts and the clamps from crossmember and LH frame rail.
- c) Remove the clamp from RH side frame rail.

## 28. REMOVE THE REMAINING COMPONENTS

- Front Spring Bumpers
- Rear Spring Bumpers
- Cab Mounting Cushions (Qty: 8)







## 29. REMOVE THE FRAME FROM THE LIFT

### 30. REMOVE THE FRAME FROM THE LIFT

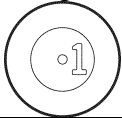
- a) Remove the ratcheting tie down strap and the frame from the lift.

### F. INSTALL FRAME PLUGS

#### 1. INSTALL THE FRAME PLUGS AS SHOWN IN THE DIAGRAMS BELOW

PLUG DIAGRAM/ID	P/N	INSTALLATION INSTRUCTIONS	TOTAL QTY
Plug '2' 	<b>90950-01A09</b>	Push to seat install.	<b>22</b>
Plug '1' 	<b>90950-01984</b>	Push to seat install.	<b>2</b>
Plug '4' 	<b>90950-01987</b>	Push to seat install.	<b>39</b>
Plug '0' 	<b>90950-01983</b>	Push to seat install.	<b>7</b>
Plug '18' 	<b>90950-01539</b>	Push to seat install.	<b>2</b>
	<b>90480-18492</b>	Push to seat install. It must be installed with the channel opening facing the outer portion of the frame to ensure road spray does not enter the frame.	<b>4</b>
	<b>90950-01A24</b>	Push to seat install	<b>4</b>

### PLUG INSTALLATION 1/6

**NOTE:**  
**RH AND LH ARE SYMMETRICAL EXCEPT WHEN NOTED.**

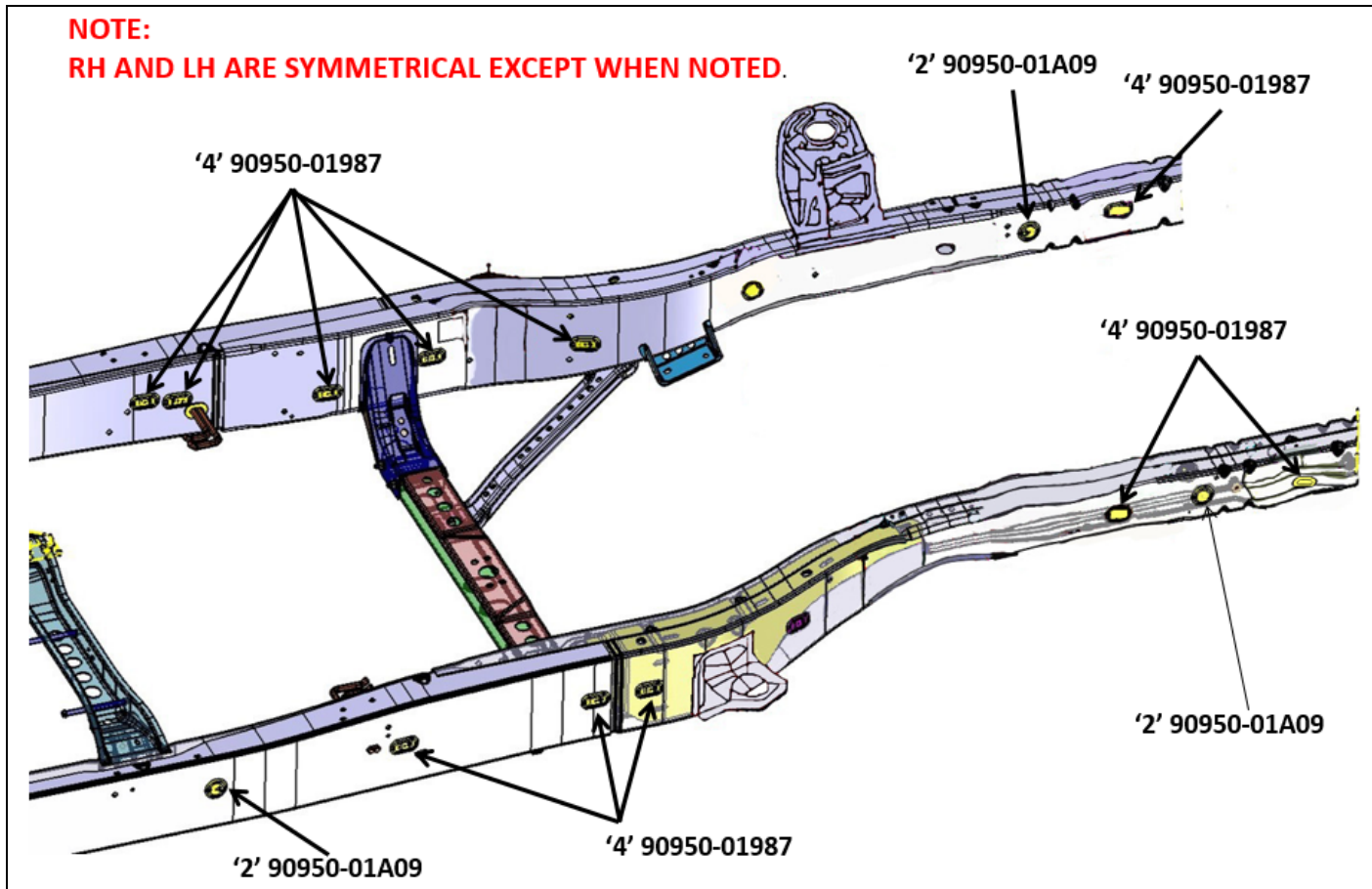

### PLUG INSTALLATION 2/6

**NOTE:**  
**RH AND LH ARE SYMMETRICAL EXCEPT WHEN NOTED.**

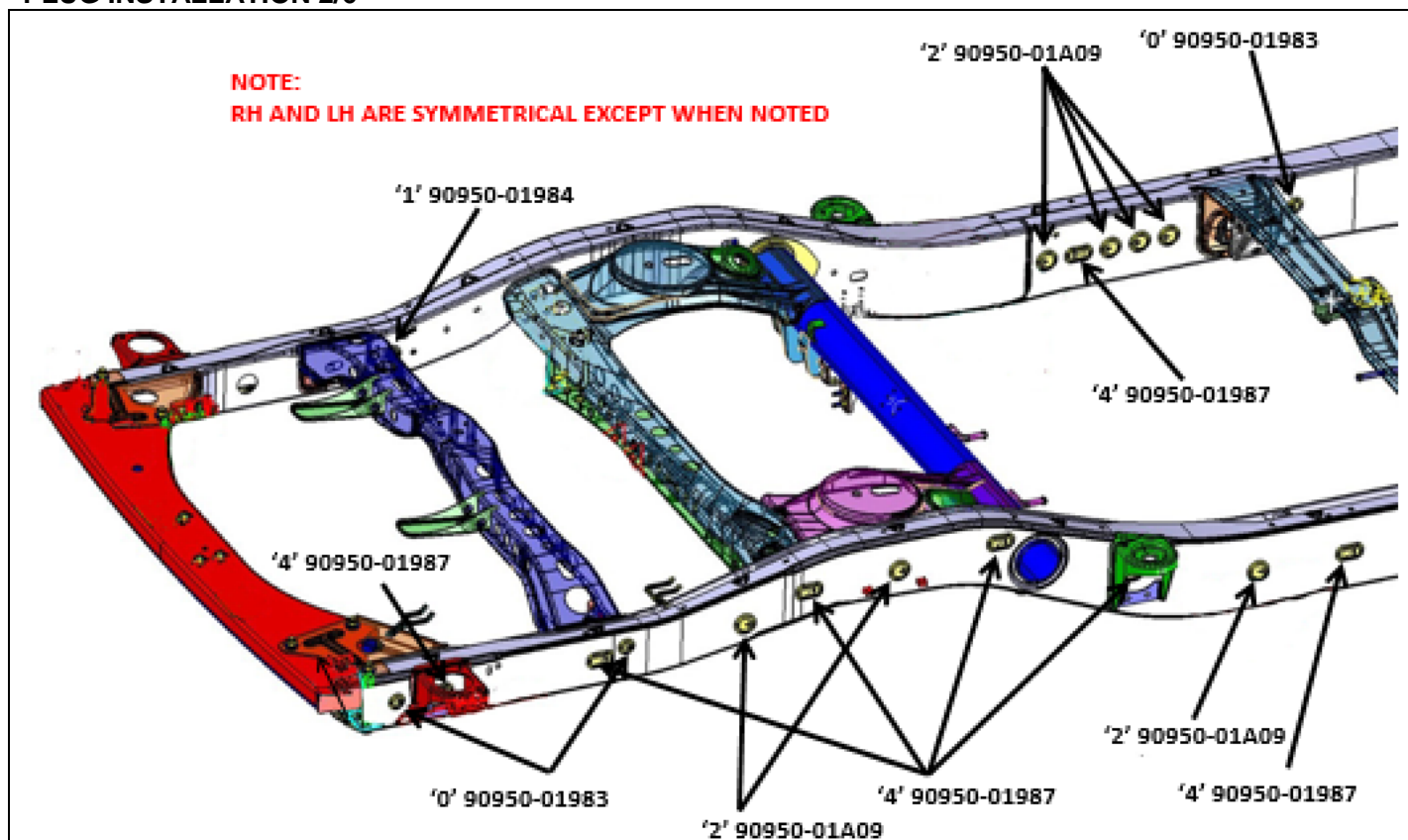

### PLUG INSTALLATION 3/6

**NOTE:**  
**RH AND LH ARE SYMMETRICAL EXCEPT WHEN NOTED.**

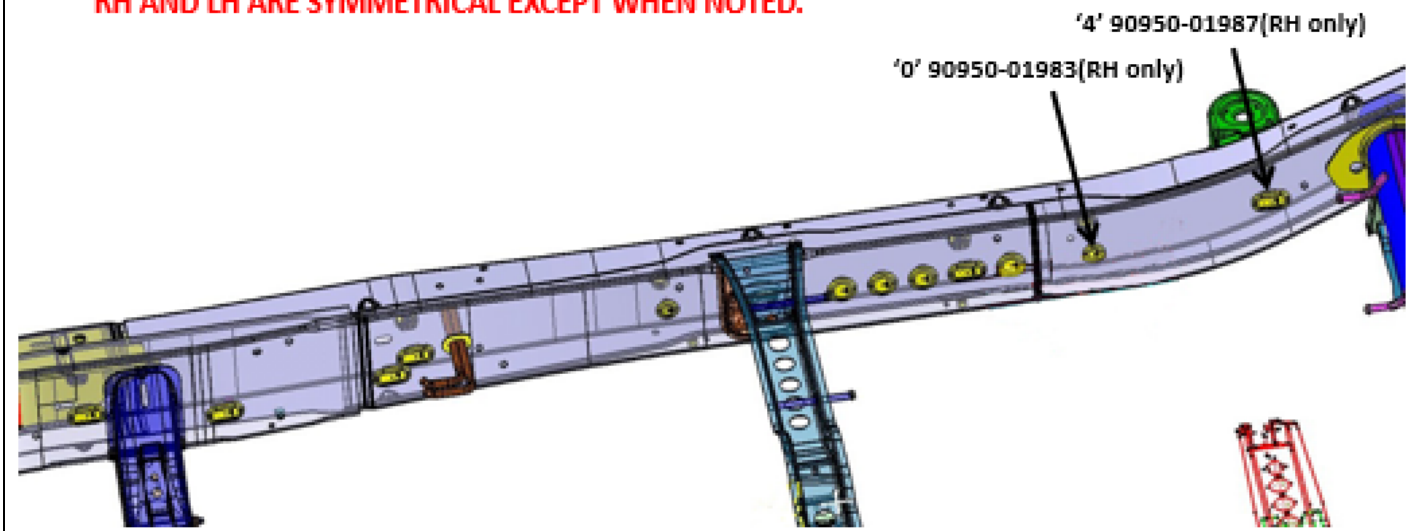

### PLUG INSTALLATION 4/6

**NOTE;**  
**RH AND LH ARE SYMMETRICAL EXCEPT WHEN NOTED.**

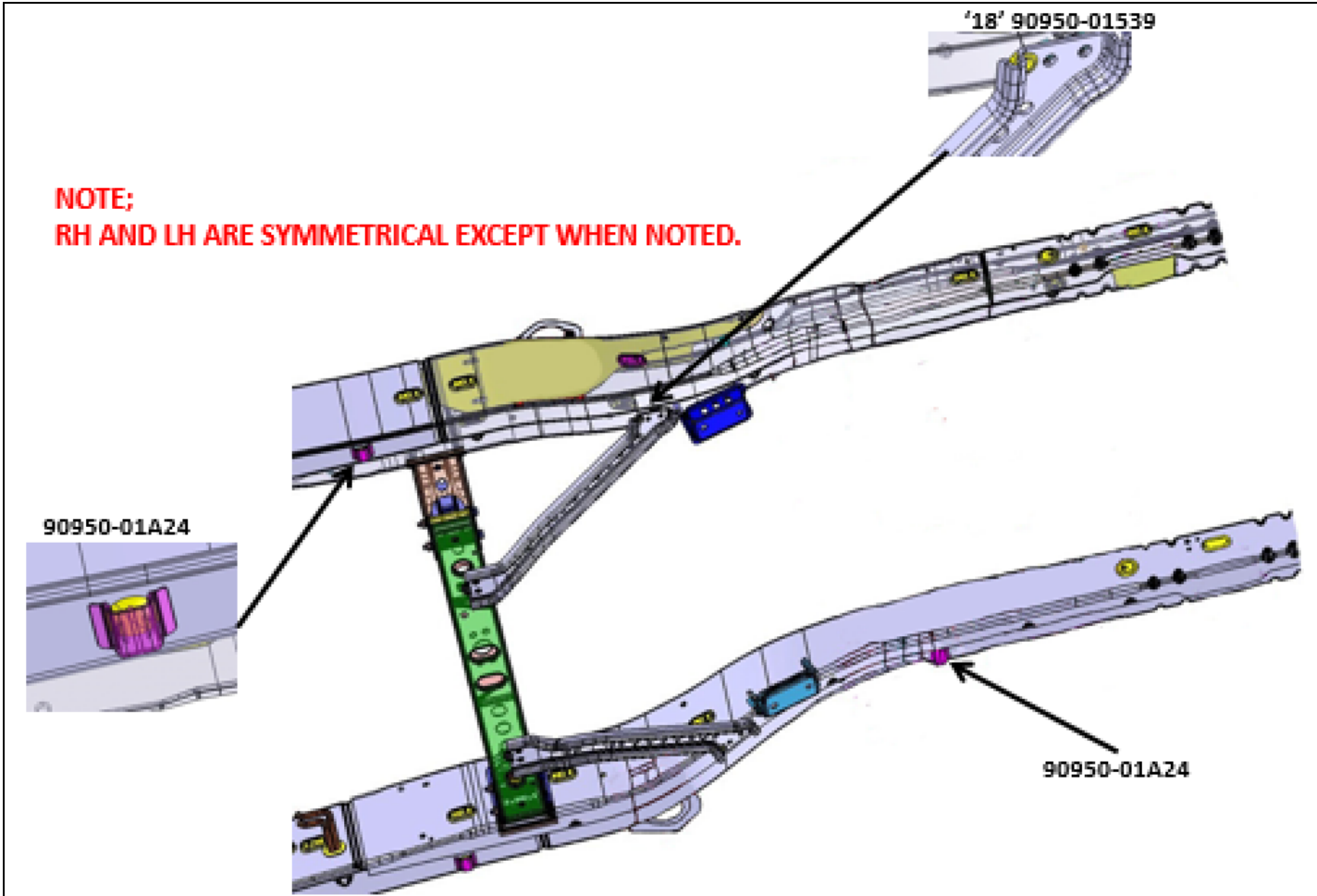



**PLUG INSTALLATION 5/6**

**NOTE;  
RH AND LH ARE SYMMETRICAL EXCEPT WHEN NOTED.**

90480-18492

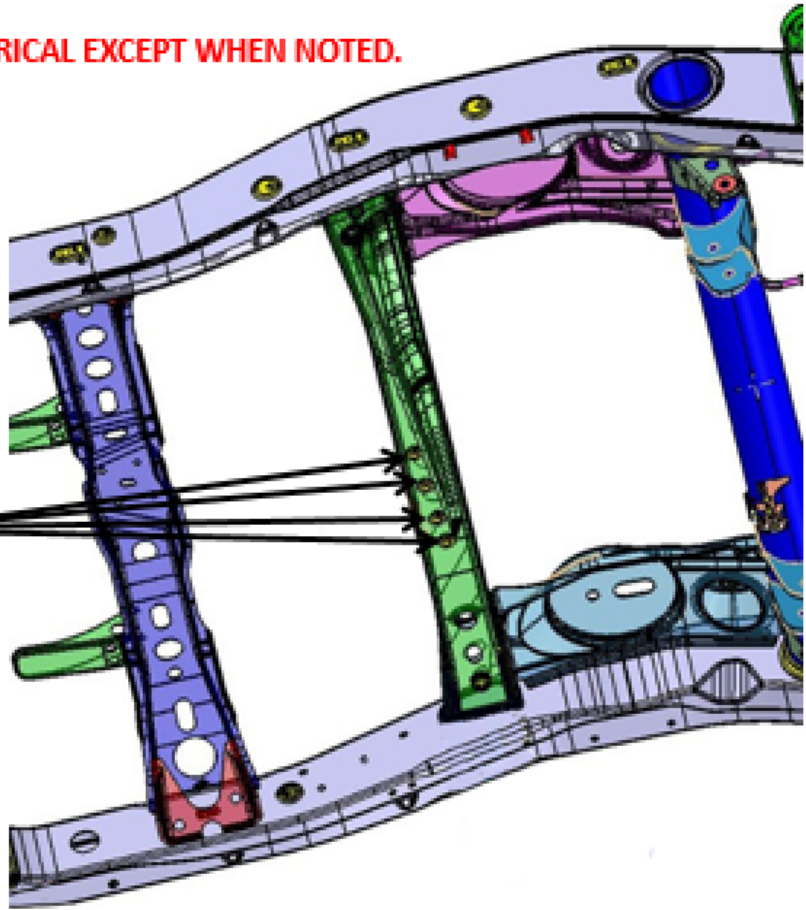

**PLUG INSTALLATION 6/6**

**NOTE:  
RH AND LH ARE SYMMETRICAL EXCEPT WHEN NOTED**

90950-01A24

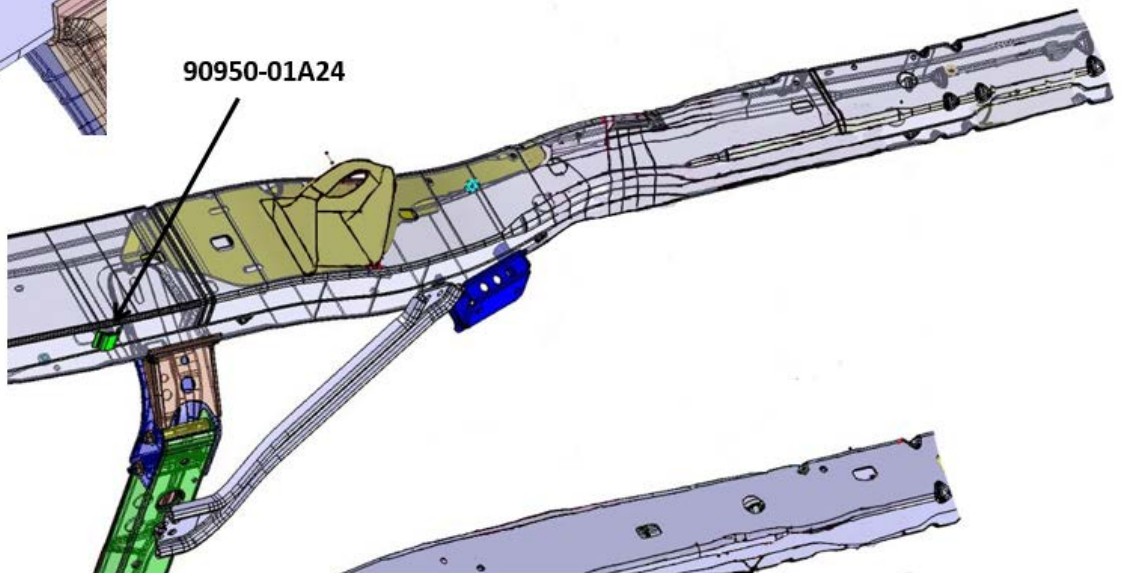
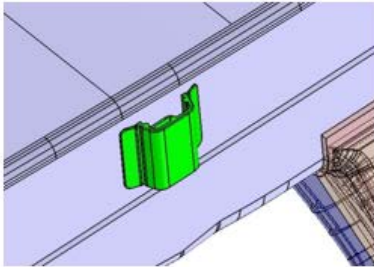

## G. ASSEMBLE THE NEW FRAME

### 1. PLACE THE *NEW* FRAME ON THE LIFT

- a) Place the **NEW** frame on the lift, and secure it with a ratcheting tie down strap. This will prevent the frame from tilting or falling off as parts are installed.

- **Ratcheting Tie Down: Qty: 1**
  - **Dimension: 2 in X 27 ft**
  - **Minimum Work Load Capacity: 3,000 lbs**

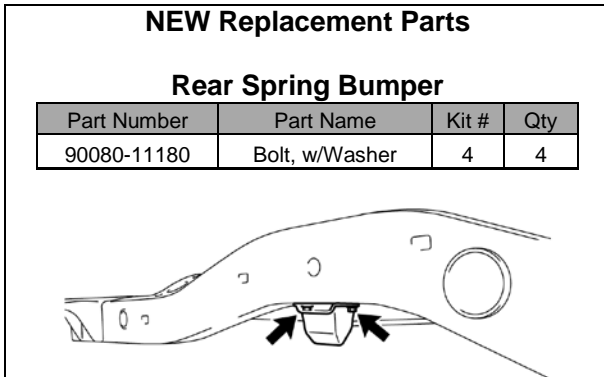

### 2. REINSTALL THE REAR SPRING BUMPER

- a) Reinstall the rear spring bumper with the 2 **NEW** bolts and torque to spec.
- b) Repeat the procedure on the opposite side.

**Torque Spec: 29 N·m (296 kgf·cm, 21 ft·lbf)**

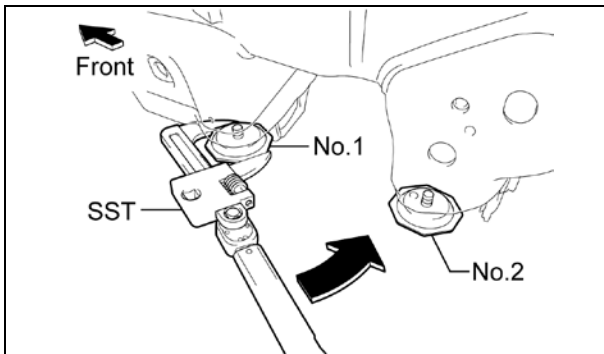

### 3. REINSTALL THE FRONT SPRING BUMPER

- a) Using the SST, reinstall the No.1 and No.2 front spring bumpers to the frame and torque to spec.
- b) Repeat the procedure on the opposite side.

**SST: 09922-10010**

**Torque Spec: 31 N·m (316 kgf·cm, 23 ft·lbf)**

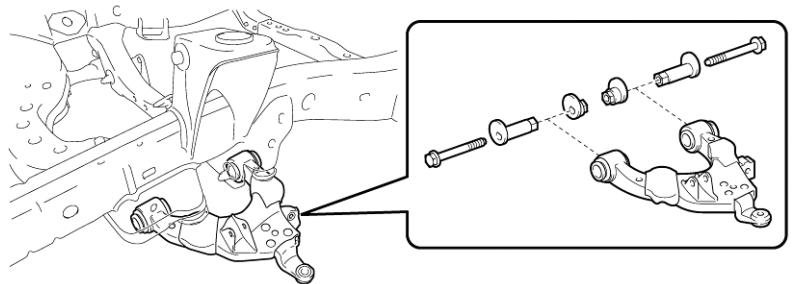
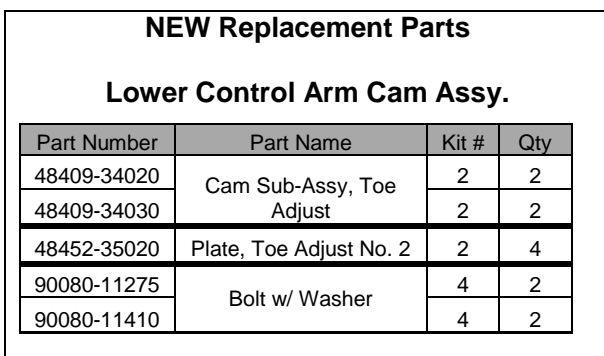

### 4. REINSTALL THE FRONT SUSPENSION LOWER CONTROL ARM

- a) Reinstall the front suspension lower control arm with 2 **NEW** bolts, 2 **NEW** toe adjustment plates, and 2 **NEW** toe adjustment cams, then torque to spec.

**Torque Spec: 140 N·m (1428 kgf·cm, 103 ft·lbf)**

- b) Repeat the procedure on the opposite side.

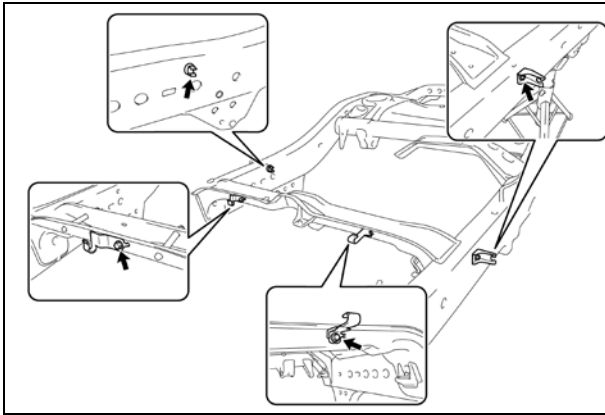

5. **REINSTALL THE PARKING BRAKE CABLE RETAINER BRACKETS AND CLAMPS**
- Reinstall the clamp.
  - Reinstall the clamps with the 2 bolts and torque to spec.
  - Reinstall the front parking brake cable retainer bracket with the bolt and torque to spec.

**Torque Spec: 26 N·m (265 kgf·cm, 19 ft·lbf)**

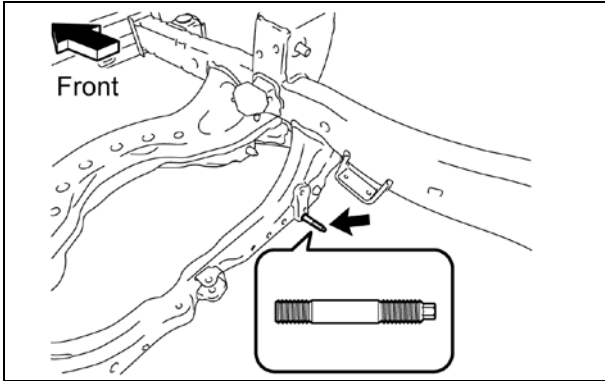

6. **REINSTALL THE STEERING GEAR STUD BOLT**
- Reinstall the stud bolt and torque to spec.

**Torque Spec: 20 N·m (204 kgf·cm, 15 ft·lbf)**

**NEW Replacement Parts**

**Front Bumper Reinforcement**

Part Number	Part Name	Kit #	Qty
90178-10024	Nut, Flange	2	4

7. **REINSTALL THE FRONT BUMPER REINFORCEMENT**
- Reinstall the front bumper reinforcement with the 4 **NEW** nuts and torque to spec.

**Torque Spec: 50 N·m (510 kgf·cm, 37 ft·lbf)**

**NEW Replacement Parts**

**Rear Bumper Reinforcement**

Part Number	Part Name	Kit #	Qty
90119-A0026	Bolt w/Washer	4	4
90119-A0027	Bolt w/ Washer	4	2
94130-01232	Nut, Hexagon	2	6
94622-31200	Washer, Plate	2	6

8. **INSTALL THE REAR BUMPER REINFORCEMENT SET (If applicable)**
- Install the rear bumper reinforcement set with the 6 **NEW** bolts, 6 **NEW** nuts and 6 **NEW** washers, then torque to spec.

**Torque Spec: 95 N·m (970 kgf·cm, 70 ft·lbf)**

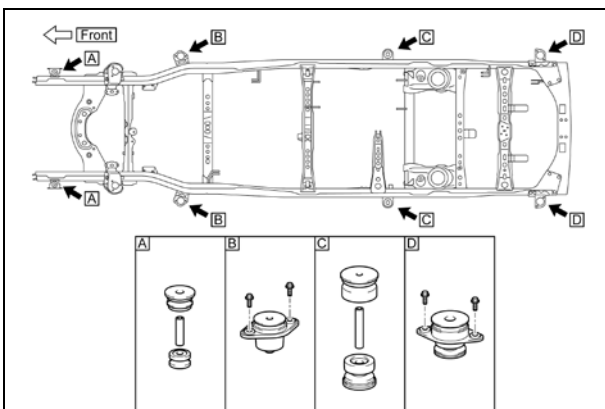

9. **REINSTALL THE CAB MOUNTS**
- Reinstall the 8 cab mounts.

**Torque Spec: 61 N·m (622 kgf·cm, 45 ft·lbf)**



## 10. INSTALL THE **NEW** REAR BRAKE TUBES

- Install the **NEW** rear brake tubes with the 7 **NEW** clamps.
- Install the **NEW** 2 way with the **NEW** bolt and torque to spec.

**Torque Spec: 28 N·m (286 kgf·cm, 21 ft·lbf)**

### NEW Replacement Parts

Part Number	Part Name	Kit #	Qty
47323-0C020	Tube, RR Brake, No.3	N/A*	1
47326-0C020	Tube, RR Brake, No.6	N/A*	1
90904-12068	Way, 2	2	1
90949-01C06	Clamp	2	7
91621-B0816	Bolt w/ Washer	2	1

\*Individual Part (s)

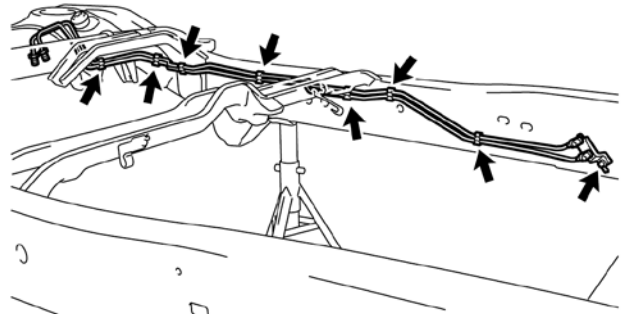

## 11. REINSTALL THE FUEL TUBES

- Reinstall the fuel tubes with the **NEW** bolts and **NEW** clamps, then torque to spec.

### Torque Specs:

**Clamp Bolt - 29 N·m (296 kgf·cm, 21 ft·lbf)**

**Filter Bolt - 20 N·m (204 kgf·cm, 15 ft·lbf)**

**NOTE:**The number of bolts and clamps will differ depending on the vehicle specs.

### NEW Replacement Parts

Part Number	Part Name	Kit #	Qty
77285-34031	Clamp, Fuel Tube, No.1 (TYPE A)	2	5
90080-11180	Bolt, w/ Washer	4	2

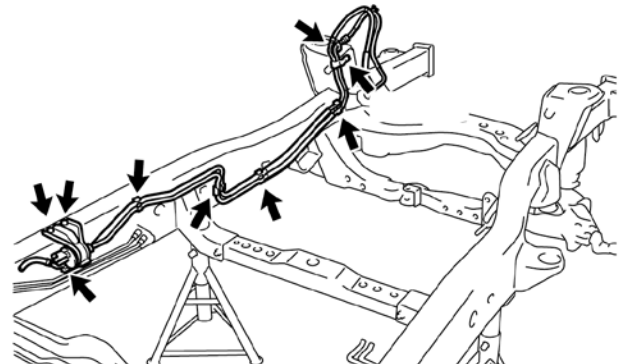

## 12. INSTALL THE **NEW** FRAME WIRE HARNESS

- Reconnect the clamps to install the **NEW** frame wire harness.
- Reconnect the ground wire with the bolt and torque to spec.

**Torque Spec: 29 N·m (296 kgf·cm, 21 ft·lbf)**

**NOTE:** The number of clamps will differ depending on the vehicle specs.

### NEW Replacement Parts

Part Number	Part Name	Kit #	Qty
82164-0C041	Wire, Frame	NA*	1
82164-0C120	Wire, Frame	NA*	1

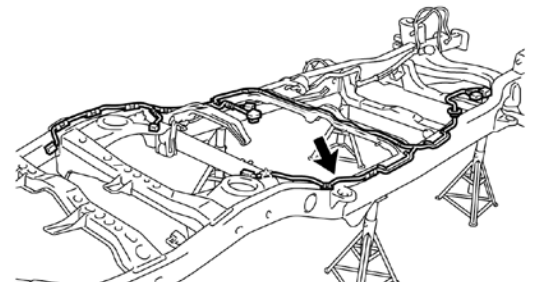

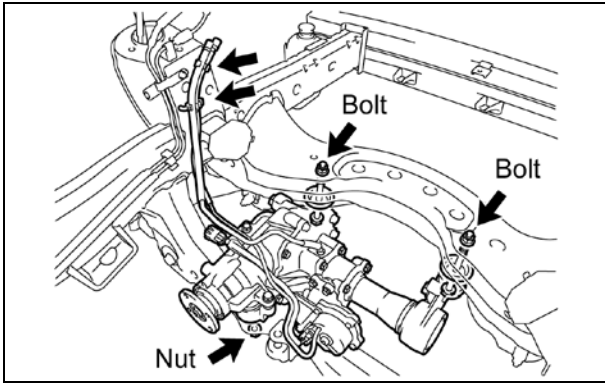

**13. REINSTALL THE FRONT DIFFERENTIAL CARRIER ASSY (4WD ONLY)**

- a) Reinstall the front differential carrier assy with the 2 bolts, 4 stoppers and 3 nuts, then torque to spec.
- b) Reinstall the front differential breather tube with the 2 clamps.

**Torque Spec:**  
**Bolt - 137 N·m (1397 kgf·cm, 101 ft·lbf)**  
**Nut - 87 N·m (887 kgf·cm, 64 ft·lbf)**

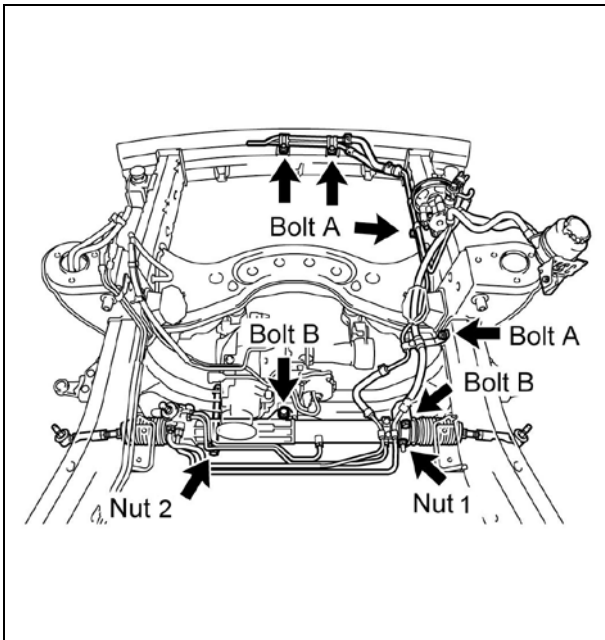

**14. REINSTALL THE POWER STEERING LINK ASSY W/ POWER STEERING VANE PUMP**

- a) Reinstall the power steering link assy w/ power steering vane pump with the 6 bolts, washer and 2 nuts, then torque to spec.

**Torque Spec:**  
**Bolt A - 29 N·m (296 kgf·cm, 21 ft·lbf)**  
**Bolt B - 165 N·m (1682 kgf·cm, 122 ft·lbf)**  
**Nut 1 - 165 N·m (1682 kgf·cm, 122 ft·lbf)**  
**Nut 2 - 130 N·m (1326 kgf·cm, 96 ft·lbf)**

**NOTE:**

- When reinstalling the power steering link with the vane pump attached, have one person support the power steering link and the other support the vane pump.
- Make sure to keep the power steering pump reservoir in an upright position to prevent the fluid from leaking out.

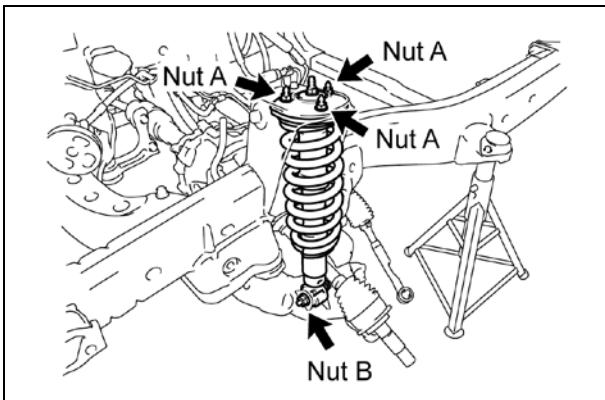

**15. REINSTALL THE FRONT SHOCK ABSORBER ASSY**

- a) Reinstall the front shock absorber assy with 3 nut (A) and torque to spec.
- b) Reinstall the front shock absorber assy to the lower control arm with the bolt and nut (B), then torque to spec.

**Torque Spec:**  
**Nut A - 64 N·m (653 kgf·cm, 47 ft·lbf)**  
**Nut B - 135 N·m (1377 kgf·cm, 100 ft·lbf)**

- c) Repeat the procedure on the opposite side.

NEW Replacement Parts			
Front Drive Shaft			
Part Number	Part Name	Kit #	Qty
43425-04020	Ring, Drive Shaft Snap	N/A*	2

\*Individual Part(s)

**16. REINSTALL THE FRONT DRIVE SHAFTS (4WD ONLY)**

- a) Install a **NEW** snap ring.
- b) Reinstall the front drive shaft.
- c) Repeat the procedure on the opposite side.

**NOTE: Be careful not to damage the dust cover and oil seal.**

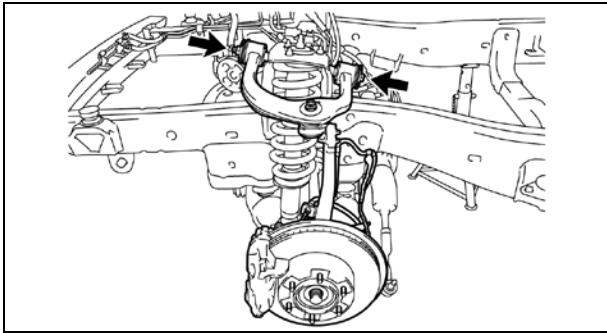

### 17. REINSTALL THE FRONT SUSPENSION UPPER ARM W/ STEERING KNUCKLE

- a) Reinstall the front suspension upper arm w/ steering knuckle with the bolt, nut and 2 washers, then torque to spec.

**Torque Spec: 98 N·m (999 kgf·cm, 72 ft·lbf)**

- b) Repeat the procedure on the opposite side.

#### NEW Replacement Parts

##### Front Lower Ball Joint

Part Number	Part Name	Kit #	Qty
90252-03015	Pin, Cotter	2	2

##### Tie Rod End

Part Number	Part Name	Kit #	Qty
95381-03225	Pin, Cotter	2	2

##### Front Stabilizer Bar

Part Number	Part Name	Kit #	Qty
48824-34030	Bracket, Stabilizer, RH	2	1
48829-34020	Bracket, Stabilizer, LH	2	1
90080-11482	Bolt w/ Washer	4	2
90182-10004	Nut, w/ Washer	2	2

### 18. REINSTALL THE FOLLOWING PARTS

- Front Lower Ball Joints
  - Reinstall the front lower ball joint with the nut and torque to spec.
  - Install the **NEW** cotter pin.
  - **Torque Spec: 159 N·m (1621 kgf·cm, 117 ft·lbf)**
  - Repeat the procedure on the opposite side.
- Tie Rod Ends
  - Reinstall the tie rod end with the nut and torque to spec.
  - Install the **NEW** cotter pin.
  - **Torque Spec: 91 N·m (928 kgf·cm, 67 ft·lbf)**
  - Repeat the procedure on the opposite side.
- Front Axle Shaft Nuts (**4WD Only**)
  - Temporarily install the front axle nut. This nut will be tightened when the vehicle is completed.
  - Repeat the procedure on the opposite side.
- Front Stabilizer Bar
  - Reinstall the stabilizer bar and 2 **NEW** brackets with the 2 **NEW** bolts and 2 **NEW** nuts, then torque to spec.
  - **Torque Spec: 37 N·m (377 kgf·cm, 27 ft·lbf)**
  - Reinstall the stabilizer bar link with the 2 nuts and torque to spec.
  - **Torque Spec: 69 N·m (704 kgf·cm, 51 ft·lbf)**

#### NEW Replacement Parts

##### Front Speed Sensor

Part Number	Part Name	Kit #	Qty
89542-0C010	Sensor, Speed, Front RH	4	1
89543-0C010	Sensor, Speed, Front LH	4	1

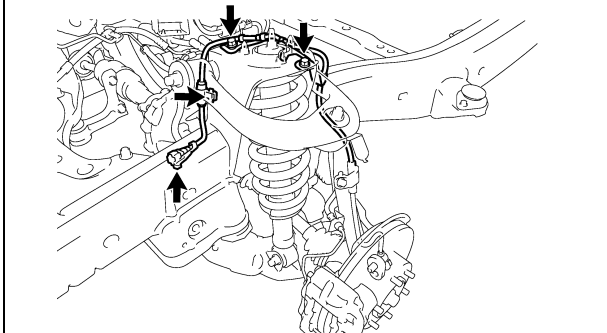

### 19. CONNECT THE NEW FRONT SPEED SENSORS

- a) Install the front speed sensor with the 3 bolts and 2 clamps, then torque to spec.

**Torque Spec: 8.0 N·m (82 kgf·cm, 71 in·lbf)**

- b) Repeat the procedure on the opposite side.

## NEW Replacement Parts

### Front Brake Flex Hose

Part Number	Part Name	Kit #	Qty
47353-35110	Bracket, Flexible Hose No. 3	2	1
47354-35100	Bracket, Flexible Hose No. 4	2	1
90468-08035	Clip	2	2
91621-B0816	Bolt, w/ Washer	2	2

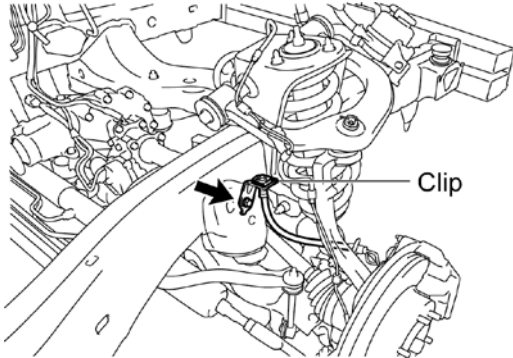

## 20. RECONNECT THE FRONT BRAKE FLEXIBLE HOSES

- Install the **NEW** bracket with the **NEW** bolt and torque to spec.

**Torque Spec: 28 N·m (286 kgf·cm, 21 ft·lbf)**

- Reconnect the flexible hose with the **NEW** clip.
- Repeat the procedure on the opposite side.

## NEW Replacement Parts

### Brake Tubes and 2 Way

Part Number	Part Name	Kit #	Qty
47314-0C011	Tube, FR Brake, No. 4	4	1
47317-0C020	Tube, FR Brake, No. 7	4	1
90904-12066	Way, 2	2	1
90904-12067		2	1
91621-B0816	Bolt, w/ Washer	1	2

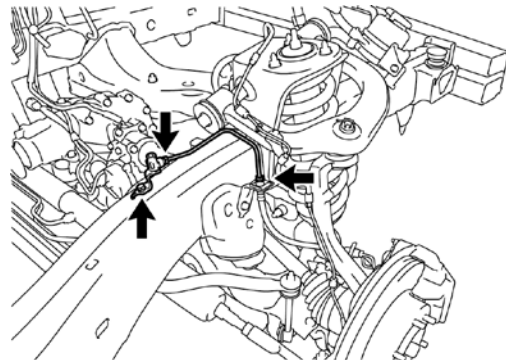

## 21. INSTALL THE NEW FRONT BRAKE TUBES AND 2 WAYS

- Temporarily install the **NEW** front brake tube and **NEW** 2 way.
- Reinstall the front brake tube and 2 way with the **NEW** bolt and torque to spec.

**Torque Spec: 28 N·m (286 kgf·cm, 21 ft·lbf)**

- Reconnect the front brake tube and torque to spec.

**Torque Spec: 15 N·m (153 kgf·cm, 11 ft·lbf)**

- Repeat the procedure on the opposite side.

## 22. REINSTALL THE REAR AXLE HOUSING W/ LINK ASSY

- Place rear axle on floor jack and position under the frame.
- Temporarily reinstall the 2 bolts, 2 nuts and 2 washers on the frame side of the lower control arms to the frame.
- Set the rear coil springs and hollow springs on the rear axle housing.

### NOTE:

- After stabilizing the suspension, torque the bolts and nuts.
- Be sure to raise one side of the rear axle housing at a time.
- Install the rear lateral control rod after positioning the body on it.

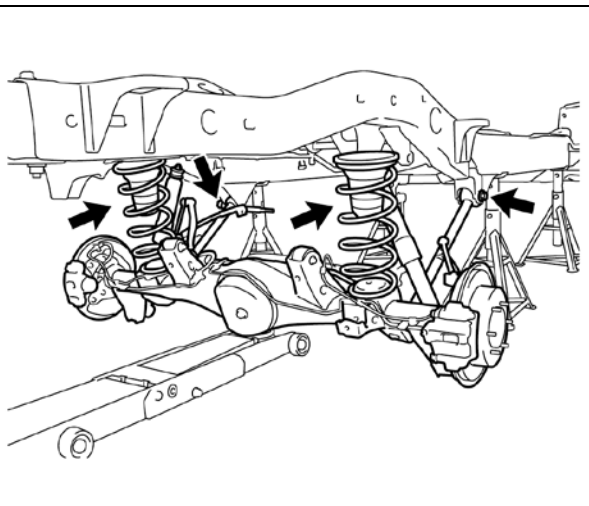

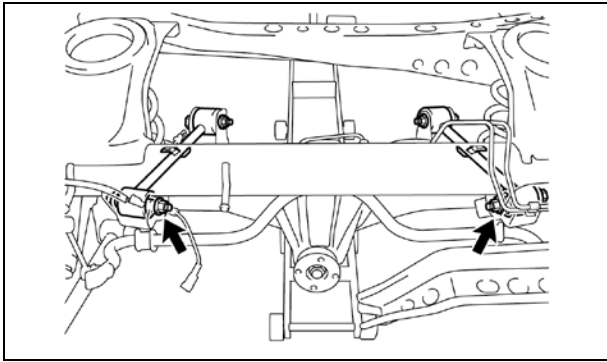

- d) Raise the jack, and temporarily install the 2 bolts, 2 nuts and 2 washers on the frame side of the No.1 rear suspension arm to the frame.

**NOTE:**

- After stabilizing the suspension, torque the bolt and nuts.
- Be sure to raise one side of the rear axle housing at a time.
- Install the rear lateral control rod after positioning the body on it.

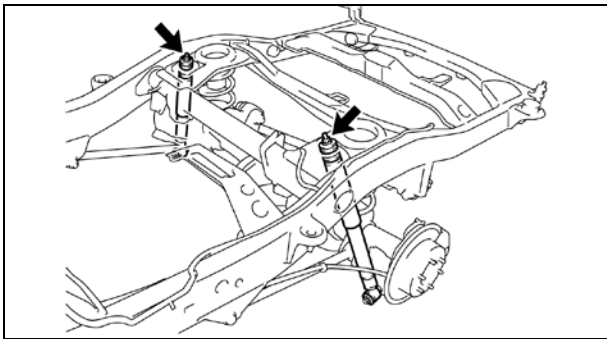

- e) Reconnect the rear shock absorbers with the 2 nuts and 2 retainers, then torque to spec.

**Torque Spec: 58 N·m (591 kgf·cm, 43 ft·lbf)**

**NEW Replacement Parts**

**Height Control Sensor**

Purt Number	Purt Name	Kit #	Qty
82711-2C250	Clamp, Wiring Harness	6	1
82711-35280		6	1
82711-3F440		6	1
90080-11180	Bolt, w/ Washer	NA*	1
90179-06292	Nut	6	1
90179-08025	Nut	6	2

\*Individual part(s)

**Rear Pneumatic Cylinder Assy**

Purt Number	Purt Name	Kit #	Qty
48932-30010	Plate, Height Control Tube	6	2
48934-30010	Connector, Height Control Tube, No.2	6	2
48958-35020	Clip, Pneumatic Cylinder	5	2
90301-04011	Ring, O	5	4

**23. REINSTALL THE FOLLOWING PARTS**

- Height Control Sensor (*w/ Air Suspension*)
  - **Torque Spec: 29 N·m (296 kgf·cm, 21 ft·lbf)**
  - **NOTE:**  
If the harness clamp is damaged, replace the **NEW** parts.
- Rear Pneumatic Cylinder Assy (*w/ Air Suspension*)

**NEW Replacement Parts**

**Rear Stabilizer Bar**

Part Number	Part Name	Kit #	Qty
90080-11482	Bolt, w/ Washer	4	4

**24. RECONNECT THE REAR STABILIZER BAR**

- a) Reconnect the 2 rear stabilizer links with the 2 nuts and torque to spec.

**Torque Spec: 69 N·m (704 kgf·cm, 51 ft·lbf)**

- b) Install the 4 **NEW** bolts and 2 brackets, then torque to spec.

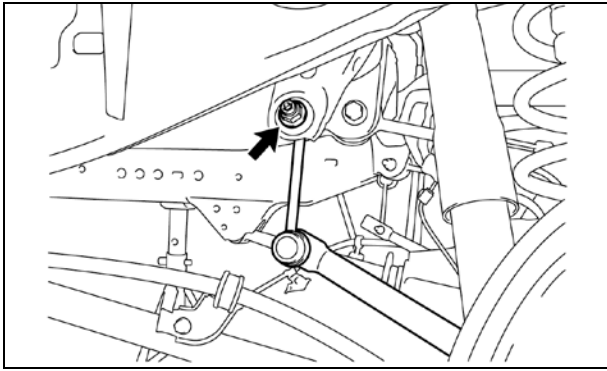

**Torque Spec: 37 N·m (377 kgf·cm, 27 ft·lbf)**

**NEW Replacement Parts**

**Rear Brake Flexible Hose**

Part Number	Part Name	Kit #	Qty
47351-34040	Bracket, Flexible Hose, No 5	2	1
90468-08035	Clip	2	2
91621-B0816	Bolt, w/ Washer	2	1

**25. RECONNECT THE REAR BRAKE FLEXIBLE HOSES**

- a) Install the No.5 flexible hose bracket with the **NEW** bolt and torque to spec.

**Torque Spec: 28 N·m (286 kgf·cm, 21 ft·lbf)**

- b) Reconnect the rear brake tubes and torque to spec.

**Torque Spec: 15 N·m (153 kgf·cm, 11 ft·lbf)**

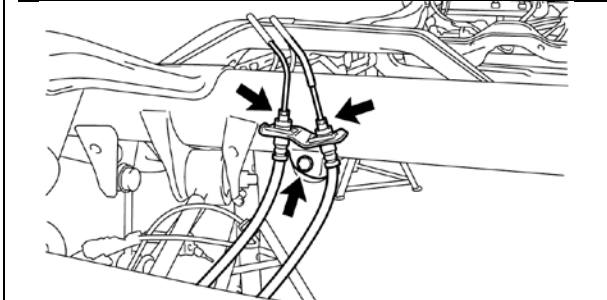

**26. REINSTALL THE NO.2 PARKING BRAKE CABLE**

- a) Reconnect the No.2 parking brake cable to the 3 clamps.
- b) Reinstall the 2 bolts and torque to spec.
- c) Reinstall the clip.

**Torque Spec: 26 N·m (265 kgf·cm, 19 ft·lbf)**

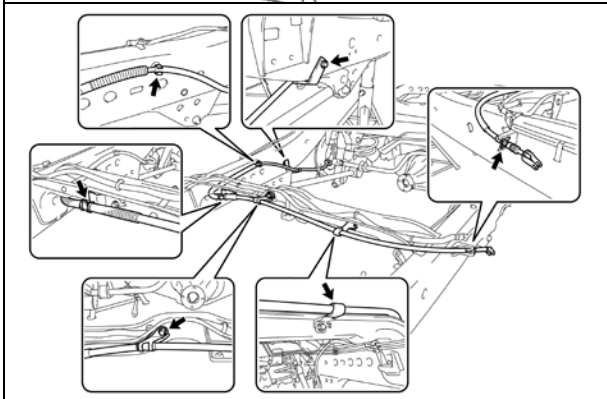

**27. RECONNECT THE NO.3 PARKING BRAKE CABLE**

- a) Reconnect the No.3 parking brake cable with the bolt and torque to spec.

**Torque Spec: 26 N·m (265 kgf·cm, 19 ft·lbf)**

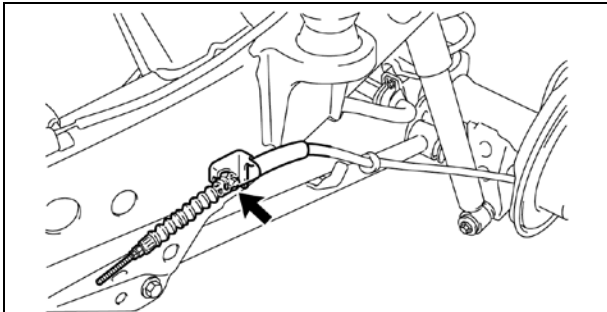

**NEW Replacement Parts**

**Rear Wheel Speed Sensors**

Part Number	Part Name	Kit #	Qty
89545-0C020	Sensor, Speed, Rear RH	4	1
89546-0C020	Sensor, Speed, Rear LH	4	1

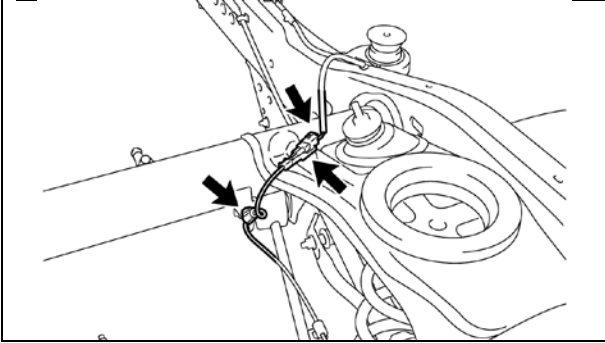

**28. CONNECT THE NEW REAR SPEED SENSOR CONNECTORS**

- a) Install the new rear speed sensor
- b) Route the rear speed sensor connector and wire with the 2 clamps.
- c) Repeat the procedure on the opposite side.

**29. REINSTALL THE 4 WHEELS**

**30. REINSTALL THE ENGINE AND TRANSMISSION ASSY**

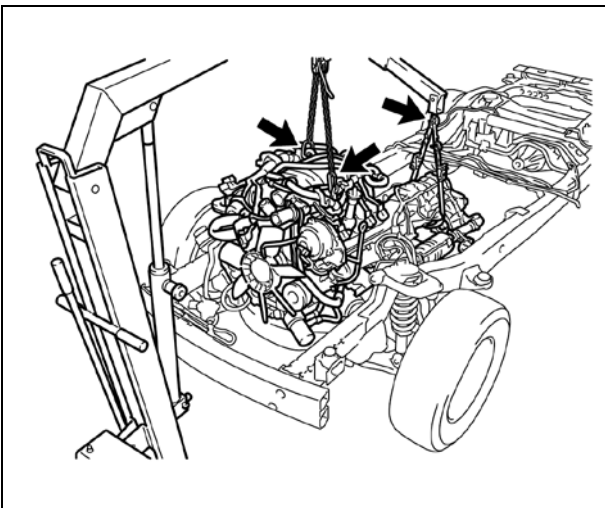

- a) Reinstall the engine and transmission assy.

**NOTE:**

- When reinstalling the engine and transmission assy, **ALWAYS** use 2 engine hoists or mini cranes.
- **DO NOT** use 1 engine hoist or mini crane to lower the engine and transmission assy, as the unbalanced weight may lead to an accident/injury.
- **ONLY** use engine hoists or mini cranes that can properly support the weight of the engine and transmission assy.
- Carefully adjust the 2 engine hoists or mini cranes so that the engine and transmission assy is properly balanced.

- b) Attach the engine mounts with the 4 bolts and 4 **NEW** nuts and torque to spec.

**Torque Spec: 38 N·m (387 kgf·cm, 28 ft·lbf)**

**NEW Replacement Parts**

**Engine Mounts**

Part Number	Part Name	Kit #	Qty
90179-10071	Nut	2	4

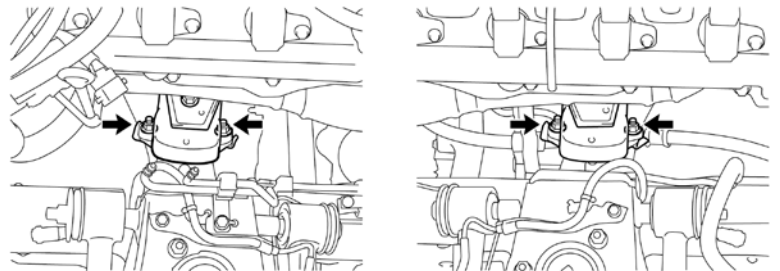

## NEW Replacement Parts

### Transmission Mount

Part Number	Part Name	Kit #	Qty
90080-11387	Bolt, w/ Washer	4	4

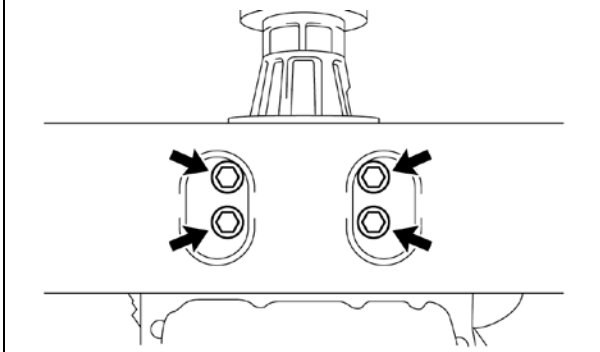

- c) Attach the transmission mount with 4 **NEW** bolts and torque to spec.

**Torque Spec: 18 N·m (184 kgf·cm, 13 ft·lbf)**

- d) Reinstall the items/parts that were removed during the engine and transmission assy removal.

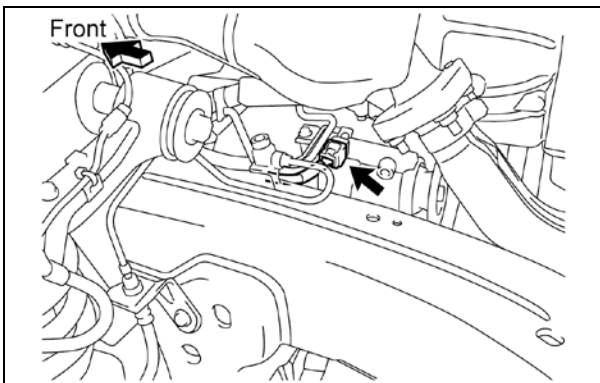

### 31. RECONNECT THE A.D.D. ACTUATOR CONNECTOR (4WD ONLY)

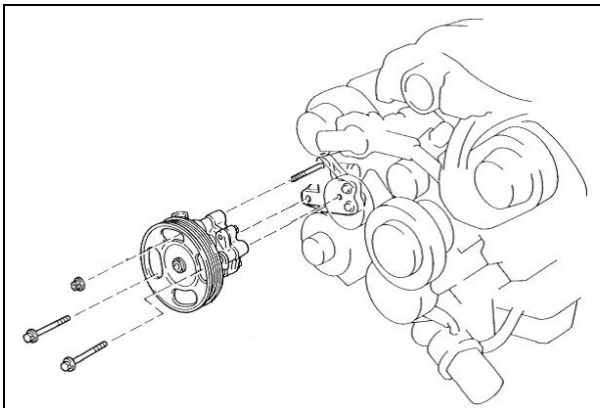

### 32. REINSTALL THE POWER STEERING VANE PUMP ONTO ENGINE ASSEMBLY ASSY

- a) Reinstall the power steering vane pump assy to the mounting bracket with the 2 bolts and nut, then torque to spec.

**Torque Spec: 28 N·m (286 kgf·cm, 21 ft·lbf)**



### 33. REINSTALL THE DRIVE BELT

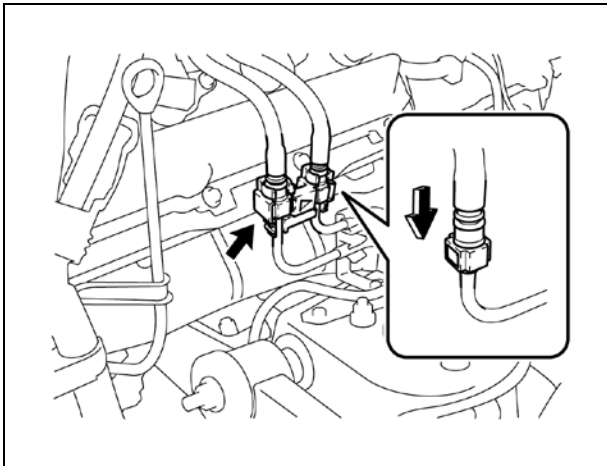

### 34. RECONNECT THE FUEL PIPES AND HOSE

- a) Reconnect the 2 fuel pipes.
- b) Reinstall the No.1 fuel pipe clamp.

**NOTE:**

- Align the axis of the connector with the axis of the pipe, and push into the connector until the connector makes a "click" sound. If the connection is tight, apply a little amount of fresh engine oil on the tip of the pipe.
- After finishing the connection, check whether the pipe and the connector are securely connected by pulling them.

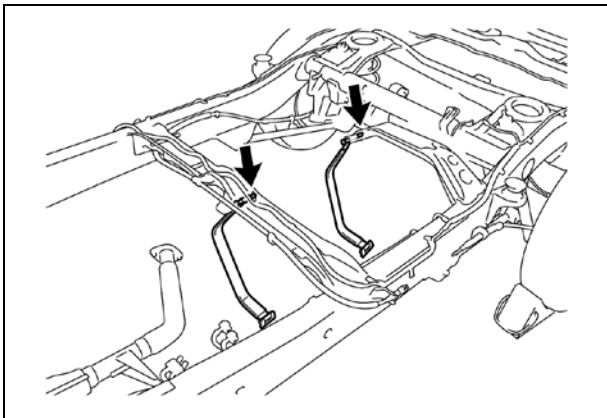

### 35. REINSTALL THE FUEL TANK STRAPS

- a) Reinstall the fuel tank straps with the 2 pins and 2 clips.

### 36. REINSTALL THE FUEL TANK

- a) Reinstall the fuel tank with the 2 **NEW** bolts and torque to spec.

**Torque Spec: 62 N·m (632 kgf·cm, 46 ft·lbf)**

- b) Reinstall the fuel tubes.
- c) Connect the clamp and connector(s).

### 37. REINSTALL THE NO.1 FUEL TANK PROTECTOR

- a) Reinstall the No.1 fuel tank protector with the **NEW** bolts and **NEW** nuts, then torque to spec.

**Torque Specs: Bolt -20 N·m (204 kgf·cm, 15 ft·lbf)**

**NOTE:**

- The number of fuel connectors will differ depending on the vehicle specs.

**NEW Replacement Parts**

**Fuel Tank Straps**

Part Number	Part Name	Kit #	Qty
90119-A0077	Bolt, w/ Washer	4	2

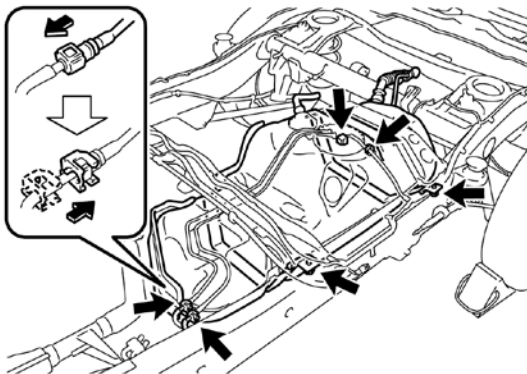

**No.1 Fuel Tank Protector**

Part Number	Part Name	Kit #	Qty
90080-11373	Bolt, w/ Washer	4	5

### 38. REINSTALL THE EXHAUST SYSTEM

- a) Install the 3 **NEW** exhaust pipe gaskets.
- b) Reinstall the center exhaust pipe with the 4 exhaust pipe supports, 2 **NEW** flange retainers and 4 bolts, then torque to spec.

**Torque Spec: 48 N·m (489 kgf·cm, 35 ft·lbf)**

- c) Reinstall the tail exhaust pipe with the 2 tail pipe brackets.
- d) Face the clamp in the direction indicated in the illustration, and torque to spec.

**Torque Spec: 32 N·m (326 kgf·cm, 24 ft·lbf)**

#### NEW Replacement Parts

##### Exhaust System

Part Number	Part Name	Kit #	Qty
90080-46263	Clamp	4	1
90917-06083	Gasket, Exhaust System**	2	2
90917-06085	Gasket Exhaust System	2	1

\*Individual Part(s)

\*\*Only 1 part # is used. The part # varies depending on vehicle model year.

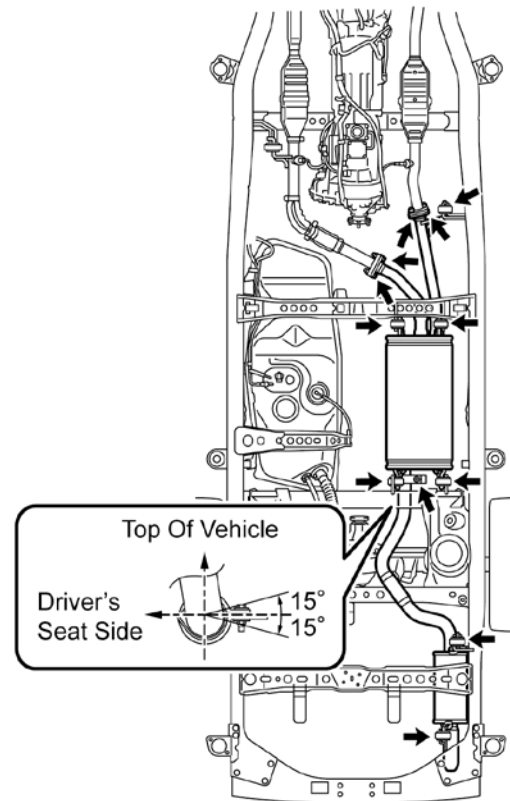

### 39. REINSTALL THE FRONT PROPELLER SHAFT (4WD ONLY)

- a) Aligning the matchmarks, install the front propeller shaft to the transfer case and the front differential with the 8 bolts, 8 washers and 8 nuts, then torque to spec.

**Torque Spec:**

**Fr Diff Side - 74 N·m (755 kgf·cm, 55 ft·lbf)**

**Rr T/F Side - 88 N·m (897 kgf·cm, 65 ft·lbf)**

**NEW Replacement Parts**  
**Receiver Hitch**

Part Number	Part Name	Kit #	Qty
90080-11491	Bolt, w/ Washer	4	6

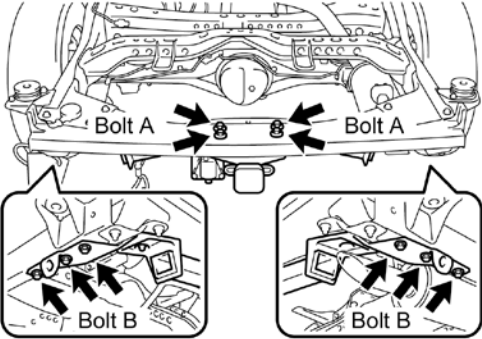

The diagram shows the front propeller shaft assembly. Two main views are provided: a top-down view of the shaft with two arrows pointing to 'Bolt A' locations, and two side-view insets showing 'Bolt B' locations on the mounting brackets.

### 40. REINSTALL THE RECEIVER HITCH BRACKET SUB-ASSY (IF EQUIPPED)

- a) Reinstall the receiver hitch bracket sub-assy with the 4 bolts and 6 **NEW** bolts and torque to spec.

**Torque Spec: Bolt A - - 177 N·m (1805 kgf·cm, 131 ft·lbf)**

**Torque Spec: Bolt B - 105 N·m (1071 kgf·cm, 78 ft·lbf)**

**NEW Replacement Parts**  
**Spare Tire Carrier**

Part Number	Part Name	Kit #	Qty
90080-11180	Bolt, w/ Washer	4	4

\*Individual Part(s)

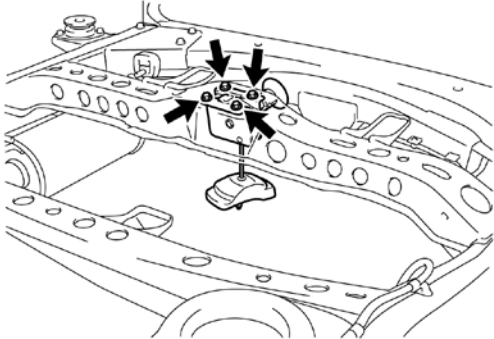

The diagram shows the rear suspension area with a spare tire carrier being installed. Four arrows point to the specific locations where the bolts should be installed on the carrier's mounting brackets.

### 41. INSTALL THE SPARE TIRE CARRIER

- a) Install the spare tire carrier with the 4 **NEW** bolts and torque to spec.

**Torque Spec: 20 N·m (204 kgf·cm, 15 ft·lbf)**

**NOTE:**

**Install the spare wheel after tightening the rear suspension arms.**

## 42. REMOVE THE FRAME FROM THE LIFT

- Remove the ratcheting tie down strap from the frame.
- Lower the frame to the ground.

## H. REINSTALL THE CAB BODY ASSY

### NEW Replacement Parts

Part Number	Part Name	Kit #	Qty
47313-0C012	Tube, FR Brake, No.3	4	1
47316-0C040	Tube, FR Brake, No.6	NA*	1
47322-0C070	Tube, RR Brake, No.2	NA*	1
47325-0C060	Tube, RR Brake, No.5	NA*	1

\*Individual part(s)

## 1. INSTALL THE NEW ENGINE COMPARTMENT BRAKE LINE

- Install the **NEW** No.3 and **NEW** No.6 front brake tubes.
- Install the **NEW** No.2 and **NEW** No.5 rear brake tubes.
- Torque all brake tubes to spec.

**Torque Spec: 15 N·m (153 kgf·cm, 11 ft·lbf)**

### NOTE:

The number of clamps will differ depending on the vehicle spec.

## 2. REINSTALL THE CAB BODY ASSY

- Raise the cab assy high enough so that the top of the engine clears the lowest point of the cab.
- Push the frame under the cab assy.

**Note: Line up the wheels with the alignment marks previously made to help align the frame with the cab.**

- Lower the cab assy slowly, making sure it does not interfere with anything.
- Adjust the vehicle's frame as needed to align the cab mounts with the cab assy bolts.
- Once the cab assy is set on the mounts, secure it to the frame with the 8 bolts, 8 nuts and 8 washers and torque to spec.

**Torque Specs: No.1 and No.4 Nut - 47 N·m (479 kgf·cm, 35 ft·lbf)**

**Torque Specs: No.2 Nut - 54 N·m (551 kgf·cm, 40 ft·lbf)**

**Torque Specs: No.3 Nut - 67 N·m (683 kgf·cm, 50 ft·lbf)**

### NOTE:

- DO NOT work directly underneath the vehicle when pushing the frame under the cab assy.
- Slowly lower the cab body assy while making sure that the wire harness, steering shaft and hoses do not interfere with it.
- With 2 to 3 people checking for interference, slowly lower the cab body assy to the frame.
- Center the vehicle's weight on the lift arms so that it does not slant/tilt to one side.

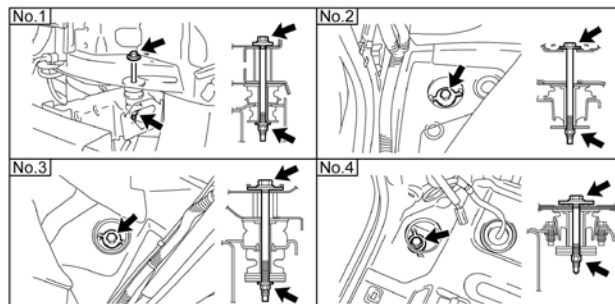
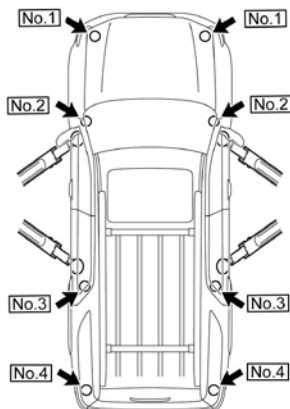

3. READJUST LIFT ARMS AND LIFT VEHICLE
4. REMOVE THE FRONT WHEELS

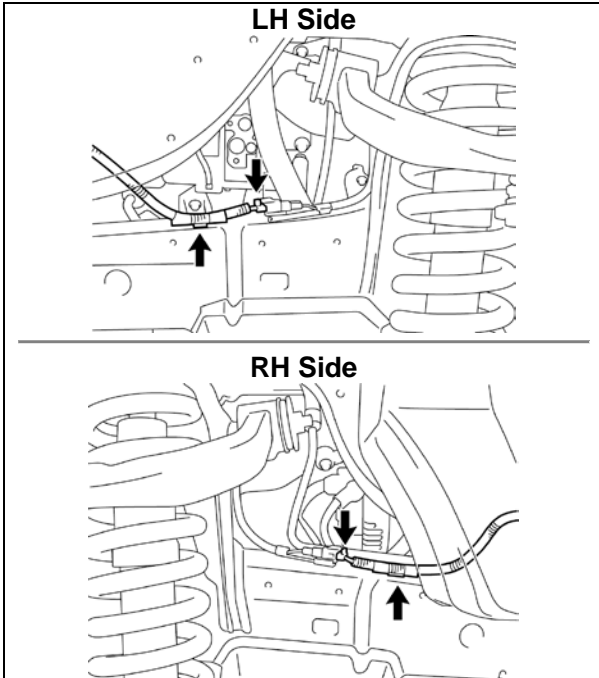

5. RECONNECT THE FRONT SPEED SENSOR CONNECTORS

- a) Reconnect the front speed sensor connector.
- b) Reinstall the clamp.
- c) Repeat the procedure on the opposite side.

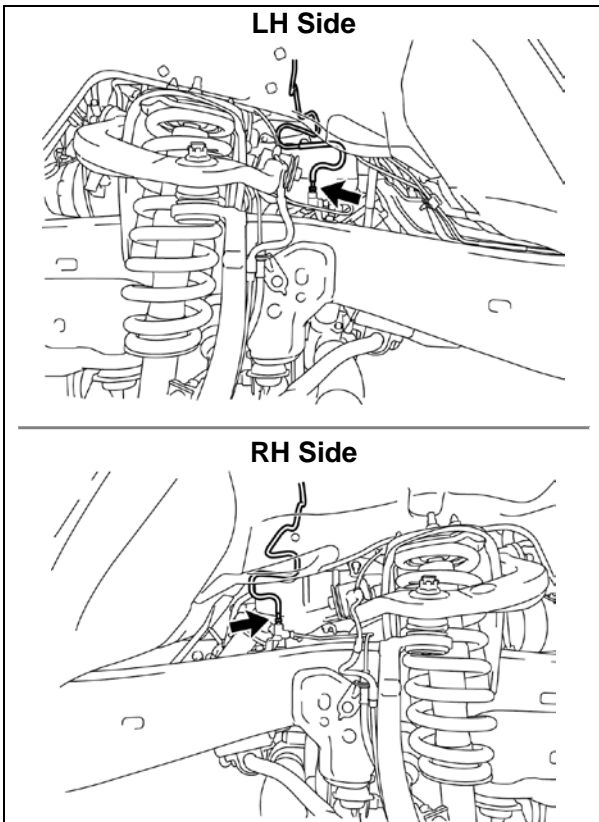

6. RECONNECT THE FRONT BRAKE TUBES

- a) Reconnect the front brake tube and torque to spec.
- b) Repeat the procedure on the opposite side.

**Torque Spec: 15 N·m (153 kgf·cm, 11 ft·lbf)**

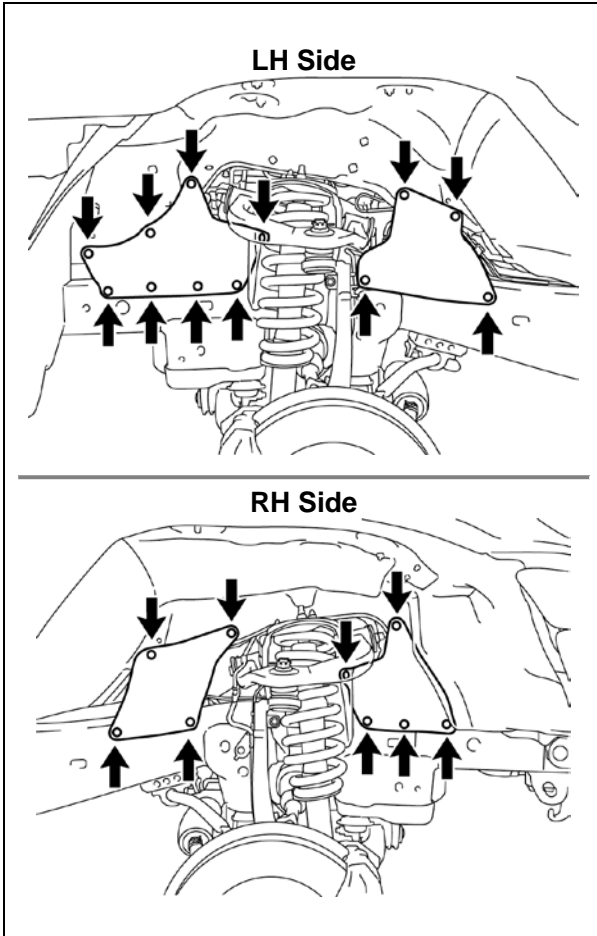

**7. REINSTALL THE FRONT FENDER APRON SEALS**

- a) Reinstall the 4 front fender apron seals with the 21 clips.

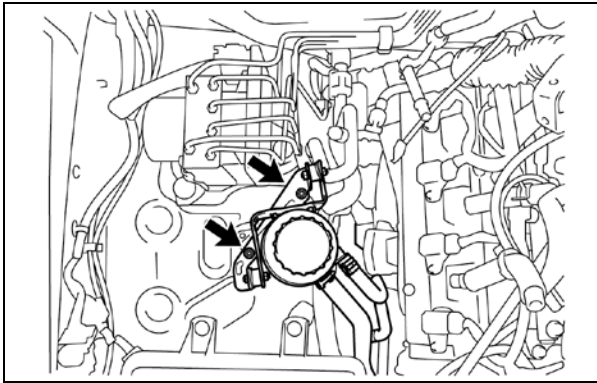

**8. RECONNECT THE VANE PUMP OIL RESERVOIR**

- a) Reinstall the vane pump oil reservoir with the 2 nuts and torque to spec.

**Torque Spec: 8.0 N·m (82 kgf·cm, 71 in·lbf)**

**9. RECONNECT THE HEATER WATER HOSE**

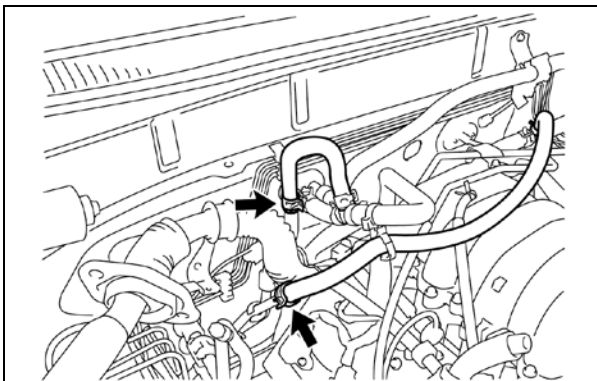

**10. RECONNECT THE REAR HEATER WATER HOSES (IF EQUIPPED)**

- a) Reconnect the 2 rear heater water hoses to the water pipe.

## NEW Replacement Parts

### A/C Line O-Rings

Part Number	Part Name	Kit #	Qty
90069-08007	Ring, O	4	1
90099-14121		2	1

## 11. RECONNECT THE A/C DISCHARGE HOSE AND SUCTION HOSE

- Install the **NEW** O-rings to the discharge hose and suction hose.
- Reinstall the discharge hose and suction hose with the nuts and torque to spec.

**Torque Spec: 10 N·m (102 kgf·cm, 7 ft·lbf)**

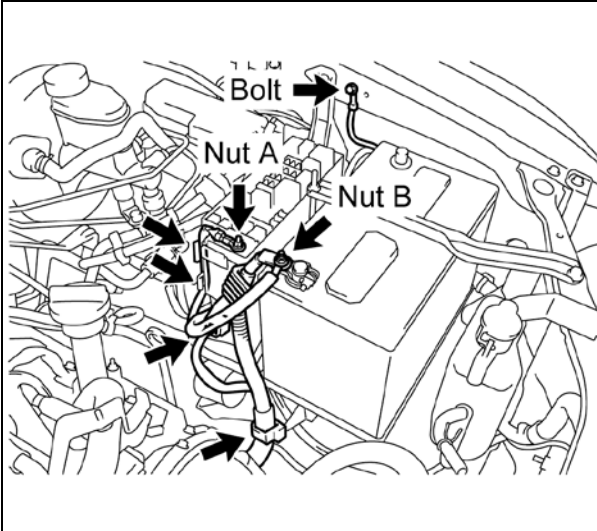

## 12. RECONNECT THE NO.2 ENGINE WIRE HARNESS

- Reinstall the No.2 engine wire harness with the nut and torque to spec.
- Reconnect the No.2 engine wire harness to the 2 clamps of the junction block.
- Reinstall the nut and reconnect the positive (+) battery cable and torque to spec.
- Reinstall the bolt and reconnect the ground wire to the LH side inner fender and torque to spec.
- Reconnect the connector and clamp.
- Reinstall the fuel pump relay.
- Reinstall the relay block cover.

**Torque Specs: Nut A - 10 N·m (102 kgf·cm, 7 ft·lbf)**

**Torque Specs: Nut B - 13 N·m (133 kgf·cm, 10 ft·lbf)**

**Torque Specs: Bolt - 8.0 N·m (82 kgf·cm, 71 in·lbf)**

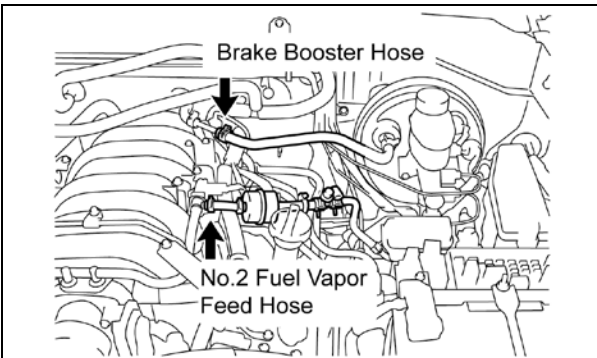

## 13. RECONNECT THE FOLLOWING ENGINE COMPARTMENT HOSES

- Reconnect the No.2 fuel vapor feed hose
- Reconnect the brake booster hose.

## NEW Replacement Parts

### Drain Cock O-Ring

Part Number	Part Name	Kit #	Qty
16492-21050	Ring, O Radiator	2	1

## 14. REINSTALL THE RADIATOR

- Install the **NEW** radiator drain cock plug O-ring.
- Tighten the radiator drain cock plug.
- Reinstall the radiator with the 4 bolts and torque to spec.

**Torque Spec: 12 N·m (122 kgf·cm, 9 ft·lbf)**

- Reconnect the upper and lower radiator hoses, automatic transmission cooler hoses.
- Reinstall the fan shroud.
- If equipped** re-install external transmission cooler

## 15. REINSTALL THE FOLLOWING PARTS

- Air Cleaner
- Throttle Body Cover
  - **Torque Spec: Nut - : 9.0 N·m (92 kgf·cm, 80 in·lbf)**

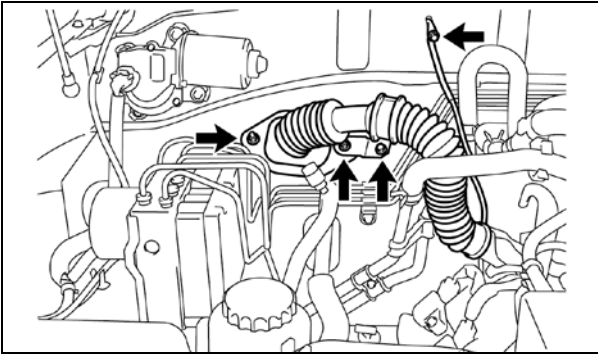

## 16. RECONNECT THE ENGINE WIRE HARNESS

- a) Reinstall the engine wire harness connector with the 2 nuts and torque to spec.
- b) Reinstall the bolt and torque to spec.

**Torque Spec: 8.0 N·m (82 kgf·cm, 71 in·lbf)**

- c) Reconnect the ground wire to the cowl panel with the bolt and torque to spec.

**Torque Spec: 8.0 N·m (82 kgf·cm, 71 in·lbf)**

### NEW Replacement Parts Rear Bumper Extension

Part Number	Part Name	Kit #	Qty
90178-08011	Nut, Flange	2	4
90119-A0064	Bolt, w/ Washer	4	4

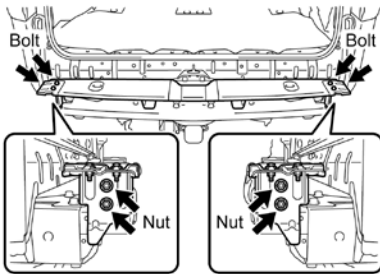

## 17. REINSTALL THE REAR BUMPER EXTENSION MOUNTING BRACKET W/ BACK STEP REINFORCEMENT

- a) Reinstall the rear bumper extension mounting bracket w/ back step reinforcement with the 4 **NEW** nuts and torque to spec.
- b) Install the 4 **NEW** bolts and torque to spec.

**Torque Spec: 19 N·m (194 kgf·cm, 14 ft·lbf)**

## 18. REINSTALL THE FOLLOWING REAR BODY COMPONENTS

- Rear Bumper Cover
  - **Torque Spec: 7.0 N·m (71 kgf·cm, 62 in·lbf)**
- Rear Quarter Panel Mudguard LH/RH

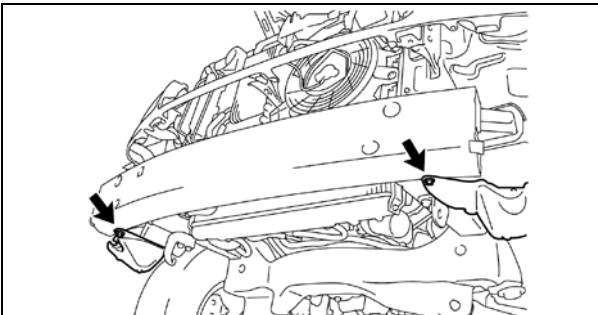

## 19. RECONNECT THE FRONT FENDER LINER

- a) Reconnect the front fender liners with the 2 screws.

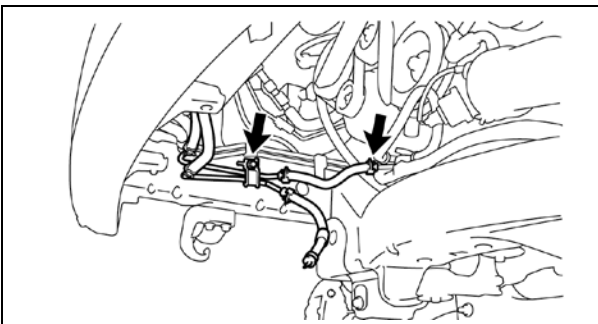

## 20. RECONNECT THE AUTOMATIC TRANSMISSION NO.2 OIL COOLER OUTLET TUBE

- a) Reinstall the No.2 oil cooler outlet tube with the bolt and torque to spec.
- b) Reconnect the hose.

**Torque Spec: 12 N·m (122 kgf·cm, 9 ft·lbf)**



### NEW Replacement Parts

#### Side Step Assy LH/RH

Part Number	Part Name	Kit #	Qty
90179-08068	Nut	2	6
90119-08516	Bolt, w/ Washer	2	10

### 21. REINSTALL THE FOLLOWING FRONT BODY PARTS

- Front Bumper Energy Absorber
- Front Bumper Cover
  - **Torque Spec: 7.0 N·m (71 kgf·cm, 62 in·lbf)**
- Front Fender Mudguard LH/RH
- Side Step Assy LH/RH with the 10 new bolts and 6 new nuts.
  - **Torque Spec: 20 N·m (204 kgf·cm, 15 ft·lbf)**

### NEW Replacement Parts

#### Fuel Tank Filler and Breather Hose Clamps

Part Number	Part Name	Kit #	Qty
90460-37003	Clamp, Hose	2	1
90460-40007		2	1

### 22. RECONNECT THE FUEL TANK TO FILLER PIPE HOSE AND FUEL TANK BREATHER HOSE

- Reconnect the fuel tank to filler pipe hose with the 2 **NEW** clamps.
- Reconnect the fuel tank breather hose with the 2 **NEW** clamps.

#### NOTE:

- **Tighten the clamp of the fuel tank to filler pipe hose until it comes into contact with the stopper.**

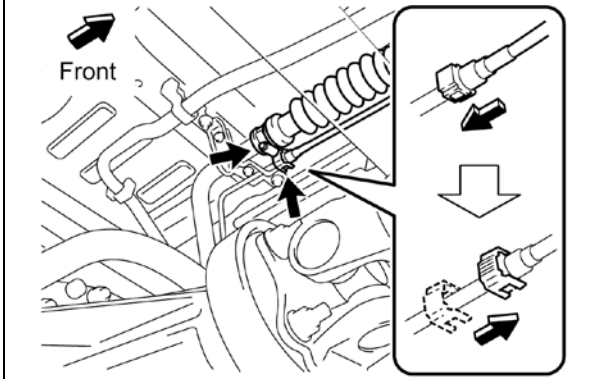

### 23. RECONNECT THE FUEL TANK VENT HOSE

#### NOTE:

- **After finishing the connection, check whether the pipe and the connector are securely connected by pulling them.**

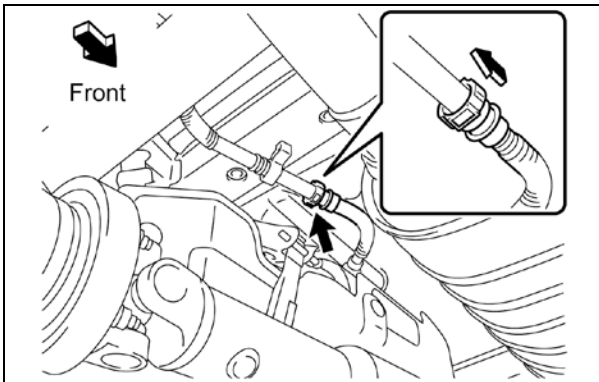

### 24. RECONNECT THE NO.1 PARKING BRAKE CABLE

- Reconnect the No.1 parking brake cable with the bolt and torque to spec.
- Reinstall the cable support bracket with the bolt and torque to spec.

**Torque Spec: 26 N·m (265 kgf·cm, 19 ft·lbf)**

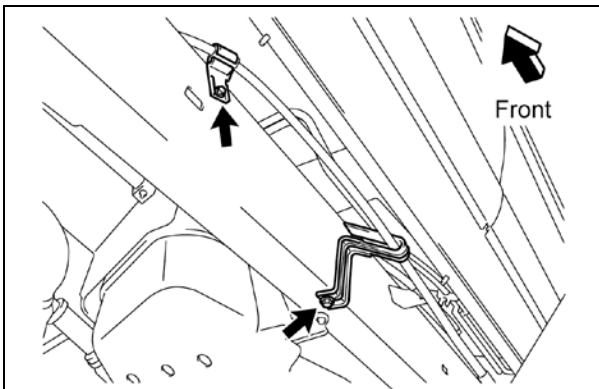

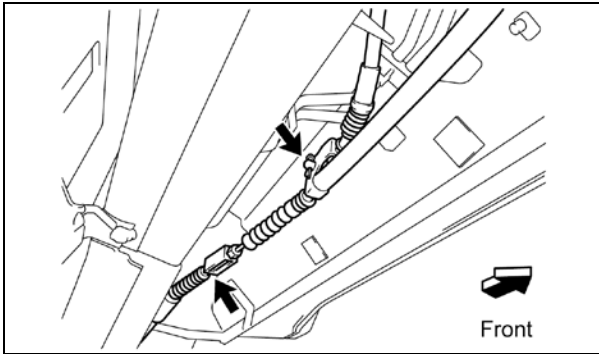

- c) Reconnect the No.2 parking brake cable with the clip and pin.
- d) Reconnect the No.1 parking brake cable to the No.3 parking brake cable and torque to spec.

**Torque Spec: 13 N·m (133 kgf·cm, 10 ft·lbf)**

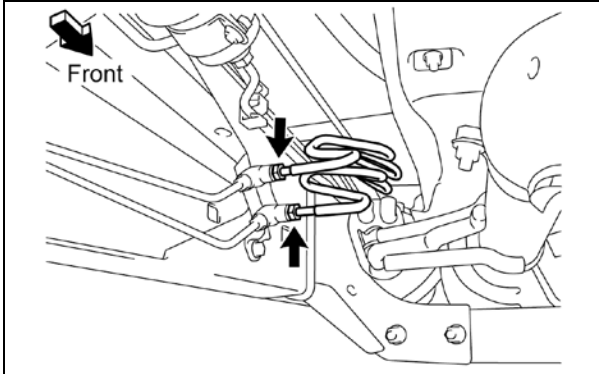

**25. RECONNECT THE REAR BRAKE TUBES**

- a) Using a flare nut wrench, connect the 2 rear brake tubes and torque to spec.

**Torque Spec: 15 N·m (153 kgf·cm, 11 ft·lbf)**

**NEW Replacement Parts  
Intermediate Shaft**

Part Number	Part Name	Kit #	Qty
90080-11555	Bolt, w/ Washer	4	2

**26. RECONNECT THE NO.2 STEERING INTERMEDIATE SHAFT**

- a) Make sure the front wheels are in a straight-ahead position and the steering wheel is centered.
- b) Aligning the matchmarks, connect the No.2 steering intermediate shaft to the control valve shaft with the **NEW** bolt (B).
- c) Remove bolt (A) and install the **NEW** bolt (A).
- d) Torque all bolts to spec.

**Torque Spec: 35 N·m (357 kgf·cm, 26 ft·lbf)**

**NEW Replacement Parts  
Auto Transmission Control Cable**

Part Number	Part Name	Kit #	Qty
90179-08054	Nut	2	1

**27. RECONNECT THE TRANSMISSION CONTROL CABLE**

- a) Reinstall the bolt and connect the transmission control cable and torque to spec.

**Torque Spec: 20 N·m (204 kgf·cm, 15 ft·lbf)**

- b) Reinstall the pin or **NEW** nut and **NEW** washer, then torque to spec.

**Torque Spec: Nut- 13 N·m (133 kgf·cm, 10 ft·lbf) (Only For Vehicles Produced On Or Before June 2003)**

**Torque Spec: Nut- 15 N·m (153 kgf·cm, 11 ft·lbf) (Only For Vehicles Produced After June 2003)**

**NOTE: Vehicles produced after August 2003 is not equipped with washer.**

## 28. REINSTALL FRONT WHEELS

## 29. LOWER THE VEHICLE

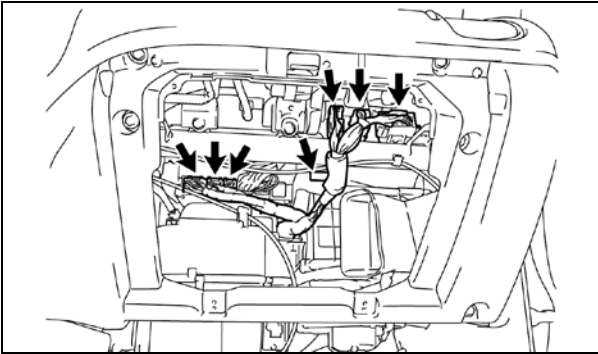

## 30. RECONNECT THE ENGINE WIRE HARNESS

- a) Reconnect the connectors and clamp.

### NOTE:

- The number of connectors will differ depending on the vehicle specs.
- Incorrectly connected connectors may cause the engine to start improperly. Be certain that the connectors are correctly connected.

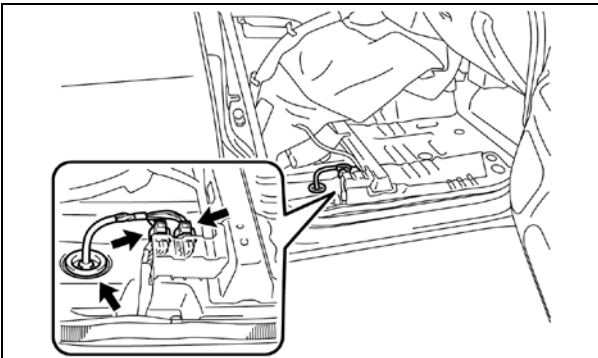

## 31. RECONNECT THE FRAME WIRE CONNECTOR

- a) Reinstall the frame wire harness grommet.
- b) Reconnect the 2 connectors.

## 32. REINSTALL THE FOLLOWING INTERIOR COMPONENTS

- a) Glove Compartment
  - No.4 Heater To Register Duct
  - Lower No.2 Instrument Finish Panel
  - Glove Compartment Door
- b) Center Console (**4WD Only**)
  - Transfer High and Low Shift Lever
  - No.1 Shift and Select Lever Boot
    - **Torque Spec: 7.0 N·m (71 kgf·cm, 62 in·lbf)**
  - Upper Console Panel
  - Shifting Hole Cover
  - Transfer Shift Lever Knob
- c) Front Seat and Trim
  - Front Seat RH
    - **Torque Spec: 37 N·m (377 kgf·cm, 27 ft·lbf)**
  - Cowl Side Trim Board LH/RH
  - Front Door Scuff Plate LH/RH
- d) Rear Passenger and Cargo Area
  - Rear Door Scuff Plate LH/RH
  - Rear Quarter Trim Panel LH/RH
  - Rear Floor Mat Support Plate
  - Rear No.2 Seat Outer Belt Floor Anchor (**If Equipped**)
    - **Torque Spec: 42 N·m (428 kgf·cm, 31 ft·lbf)**
  - Rear No.1 Seat Outer Belt Floor Anchor
    - **Torque Spec: 42 N·m (428 kgf·cm, 31 ft·lbf)**
  - Rear 3<sup>rd</sup> Row Seat (**If Equipped**)
  - Put 2<sup>nd</sup> Row Seat back into place

## 33. PUT THE REAR NO.1 SEATS BACK INTO PLACE

## I. FINAL ASSEMBLY

### 1. RECONNECT THE NEGATIVE BATTERY TERMINAL CABLE

#### NEW Replacement Parts Front Differential Gaskets (4WD Only)

Part Number	Part Name	Kit #	Qty
12157-10010	Gasket, Drain Plug	NA*	1
90430-24003	Gasket	NA*	1

### 2. REFILL THE FOLLOWING

- a) Brake Fluid
  - Fill with Toyota DOT 3 Brake Fluid.
  - Remove the brake lines from the master cylinder.
  - Bleed the master cylinder.
  - Reinstall the brake lines to the master cylinder and torque to spec.
  - **Torque Spec: 15 N·m (153 kgf·cm, 11 ft·lbf)**
    - Bleed the brake system at each wheel and torque the bleeder screws to spec.
    - **Torque Spec: 11 N·m (112 kgf·cm, 8 ft·lbf)**
  - Top off brake fluid
- b) Coolant
  - Refill with Toyota Long Life Coolant.
- c) Front Differential (**4WD Only**)
  - Install the NEW drain plug gasket and torque to spec.
  - Torque Spec: 65 N·m (663 kgf·cm, 48 ft·lbf)
  - Refill with Hypoid Gear Oil API GL-5 75W-90.
  - Install the NEW filler plug gasket and torque to spec.
  - **Torque Spec: 39 N·m (398 kgf·cm, 29 ft·lbf)**
- d) Recharge A/C System

### 3. START THE VEHICLE AND PERFORM AND INSPECT THE FOLLOWING

- Fuel System
  - Start the engine and let it run for 5 seconds, and then stop the engine and inspect for leaks.
  - If there are no leaks, restart the engine and re-inspect.
- Bleed Cooling System and Check for Leaks
- Brake System Leaks
- Front Differential System
- Operation of A/C System

### 4. INSPECT FOR A/C REFRIGERANT LEAKS

### 5. CHECK THE OPERATION OF THE FOLLOWING ITEMS AND ADJUST AS NEEDED



**Make sure to follow the procedure outlined in the appropriate repair manual for the vehicle you are working on when checking, and if needed, adjusting the operation of the items listed below. This is an important step, and must be performed thoroughly to ensure proper operation of these items.**

- Parking Brake Lever Travel
- Shift Control Lever

### 6. CHECK ALL FLUID LEVELS AND ADJUST AS NEEDED

**NEW Replacement Parts**

**Rear Lateral Control Rod**

Part Number	Part Name	Kit #	Qty
90179-14062	Nut	2	1

**7. REINSTALL AND TORQUE THE REAR LATERAL CONTROL ROD**

**Torque Specs:**

**Nut: 140 N·m (1428 kgf·cm, 103 ft·lbf)**

**Bolt: 130 N·m (1326 kgf·cm, 96 ft·lbf)**

**NOTE:**

- After stabilizing the suspension, torque the nut.
- Perform tightening with the vehicle grounded.

**8. TORQUE THE BOLTS AND NUTS OF THE REAR SUSPENSION ARMS TO SPEC**

**Torque Specs: No.1 Rear Suspension Arm (Nut) - 140 N·m (1428 kgf·cm, 103 ft·lbf)**

**Torque Specs: Bolt Of Lower Control Arm (Bolt) - 130 N·m (1326 kgf·cm, 96 ft·lbf)**

**NOTE:**

- After stabilizing the suspension, torque the bolt and nut.
- Perform tightening with the vehicle grounded.

**9. REINSTALL THE SPARE WHEEL**

**NEW Replacement Parts**

**Front Axle**

Part Number	Part Name	Kit #	Qty
95381-04045	Pin, Cotter	NA*	2

\*Individual Part(s)

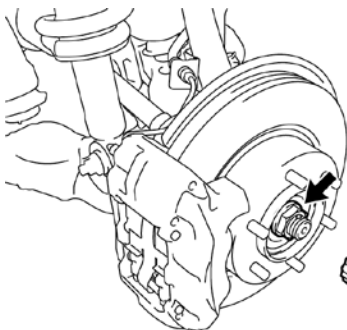

**10. TORQUE THE FRONT AXLE NUTS (4WD ONLY)**

- Remove the front wheels.
- Torque the front axle nuts to spec.

**Torque Spec: 235 N·m (2396 kgf·cm, 173 ft·lb)**

- Reinstall the lock cap with the **NEW** cotter pin.
- Reinstall the grease cap.
- Repeat the procedure on the opposite side.
- Reinstall the front wheels and torque to spec.

**Torque Spec: 112 N·m (1142 kgf·cm, 83 ft·lbf)**

**NOTE:**

If the holes for the cotter pin are not aligned, tighten the axle nut further, up to 60°.

**11. PERFORM A WHEEL ALIGNMENT**

**12. CHECK THE HEADLIGHT AIM AND ADJUST AS NEEDED**

**NEW Replacement Parts**

**Engine Under Cover**

Part Number	Part Name	Kit #	Qty
90080-11373	Bolt, w/ Washer	4	5

**13. REINSTALL THE NO.1 ENGINE UNDER COVER**

- Install the No.1 engine under cover with the **NEW** bolts and torque to spec.

**Torque Spec: 29 N·m (296 kgf·cm, 21 ft·lbf)**

**14. CHECK FOR DTCS AND REPAIR AS NEEDED**

**15. PERFORM INITIALIZATION**

## 16. FINAL INSPECTION

a) Check the operation of the following systems:

- 4WD System (**4WD Only**)
- Interior Lights
- Exterior Lights
- HVAC System
- Audio System
- Power Windows
- Power Door Locks
- All Gauges, Indicators and Warning Lights
- Cooling Fans
- Etc.

## 17. TEST DRIVE THE VEHICLE AND DOCUMENT FINAL REPAIR STATUS

a) Test drive the vehicle and perform final repair sign off with the [Frame Replacement Inspection Sheet](#). This must be performed and signed off by an MDT, Shop Foreman or Service Manager and retained with Final R.O.

## 18. RECORD THE FRAME SERIAL NUMBER

a) Log into the frame tracker website using your dealer code and password.

URL: <https://zh-frame-tracker.imagespm.info/>

Default password: xxxxx

The screenshot shows the login page for the ZH Frame Tracker Dealer Site. At the top, there is a blue header with the Toyota logo and the text "TOYOTA". Below the header, a blue bar contains the text "ZH Frame Tracker: DEALER Site". The main content area is titled "Login" and includes the instruction "Complete all required (\*) fields below." There are two input fields: "\* User ID:" with the value "82450" and "\* Password:" with masked characters "\*\*\*\*\*". A blue "Login" button is positioned below the password field, and a link for "Forgot Password?" is located at the bottom of the form.

b) Select 2005 to 2007 Sequoia ZH8 from the pick list.

The screenshot shows the vehicle selection page on the ZH Frame Tracker Dealer Site. The blue header contains "ZH Frame Tracker: DEALER Site" and "Toyota Administrator". On the right side of the header, there are links for "Search Another Vin", "Print Screen", and "Log Out". The main heading is "Prompt Vehicle Type" with the instruction "Select the vehicle type that is having the frame replaced under the WEP." Below this, a form titled "Vehicle Type" contains four radio button options: "2005 to 2010 Tacoma (ZH6)", "2007 to 2008 Tundra (ZH7) -- campaign will launch at a later date", "2005 to 2007 Sequoia (ZH8) -- campaign will launch at a later date", and "2008 Sequoia (ZH9) -- campaign will launch at a later date". A blue "Next:" button is located at the bottom of the form.

c) Enter the VIN of the vehicle.

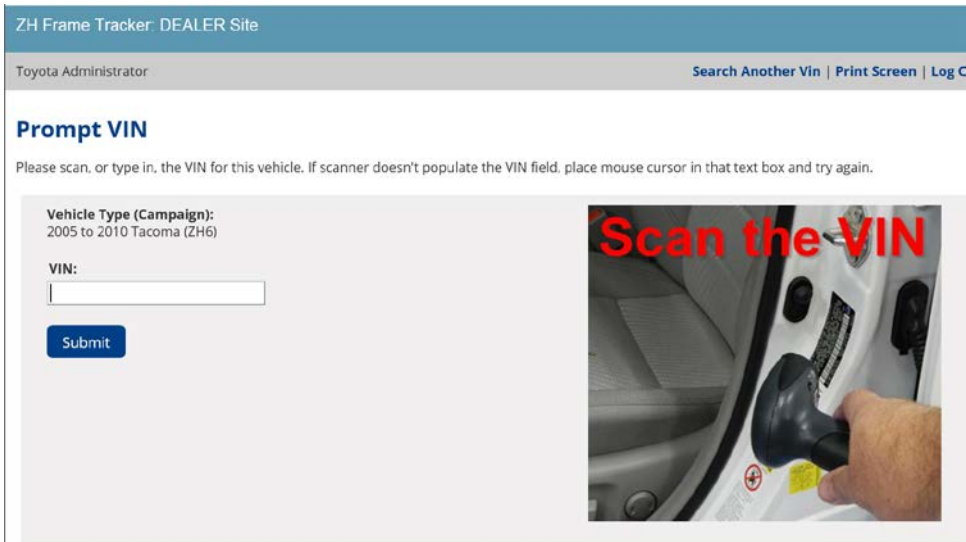

ZH Frame Tracker: DEALER Site

Toyota Administrator [Search Another Vin](#) | [Print Screen](#) | [Log C](#)

### Prompt VIN

Please scan, or type in, the VIN for this vehicle. If scanner doesn't populate the VIN field, place mouse cursor in that text box and try again.

**Vehicle Type (Campaign):**  
2005 to 2010 Tacoma (ZH6)

VIN:

**Scan the VIN**

d) Enter the frame serial off of the case label along with the R.O. number and Approved Frame Inspection Case Number.

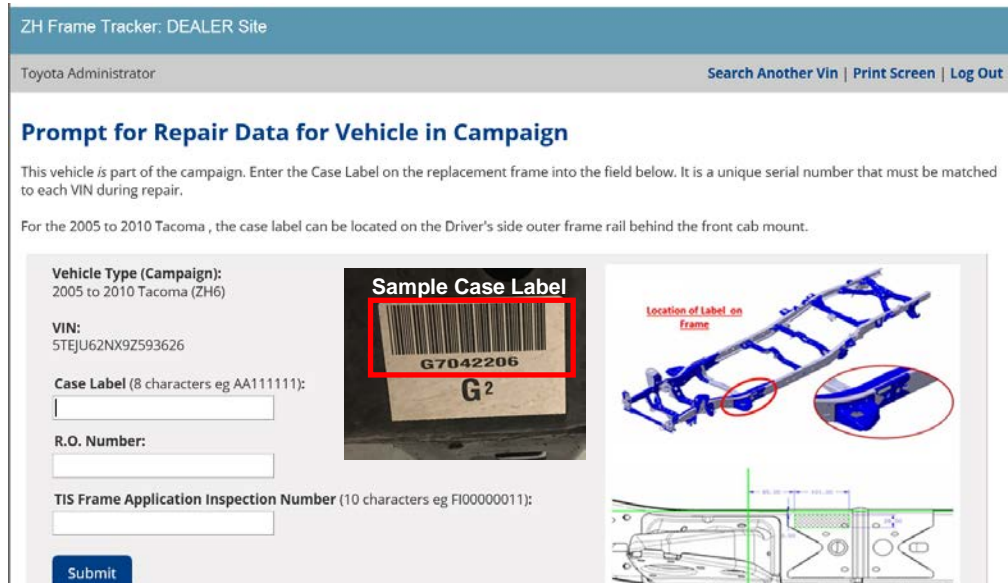

ZH Frame Tracker: DEALER Site

Toyota Administrator [Search Another Vin](#) | [Print Screen](#) | [Log Out](#)

### Prompt for Repair Data for Vehicle in Campaign

This vehicle is part of the campaign. Enter the Case Label on the replacement frame into the field below. It is a unique serial number that must be matched to each VIN during repair.

For the 2005 to 2010 Tacoma, the case label can be located on the Driver's side outer frame rail behind the front cab mount.

**Vehicle Type (Campaign):**  
2005 to 2010 Tacoma (ZH6)

VIN:  
5TEJU62NX9Z593626

**Case Label (8 characters eg AA111111):**

**R.O. Number:**

**TIS Frame Application Inspection Number (10 characters eg FI00000011):**

**Sample Case Label**

**Location of Label on Frame**

e) Press submit and print a copy of the serial number and file with the R.O.

## f) APPENDIX

As required by Federal Regulations, please make sure all recalled parts (original parts) removed from the vehicle are disposed of in a manner in which they will not be reused. Adequate time has been provided in the repair time to cut up and dispose of the perforated frame.