



**DATE:** 2-9-17

**APPLIES TO:** This service bulletin applies to 2011-2017 model year transit bus chassis cabs altered by Spartan Motors, USA Inc. built between June 16, 2011 and December 1, 2016.

**CONDITION:** Air Spring Blistering

**CORRECTION:** Replacement of air springs

**LABOR ALLOCATION:** 1.0 hrs.

**CLASSIFICATION:** V

**PARTS NEEDED:**

<u>QTY</u>	<u>Part Number</u>	<u>Description</u>
1	S-2577-001	Kit-Service, Glaval Air Spring

**Kit # S-2577-001 Contains:**

<u>QTY</u>	<u>Part Number</u>	<u>Description</u>
1	0461-SS2-001	Springs, Air, Glaval IFS
1	TSB17-250-001	Instruction Document
1	TSB17-250-002	Instruction Document

**GENERAL INSTRUCTIONS:**

Thoroughly review entire service bulletin before starting work. If there are questions or concerns with steps defined in this service bulletin, contact Spartan Motors USA, Inc. Customer & Product Support Group.

All applicable industry safety standards must be followed when performing work identified in this procedure.

Service Bulletins are intended for use by Professional Technicians only. They are written to guide Professional Technicians in performing service to vehicles of specific nature in conjunction with industry standards. Professional Technicians should be appropriately trained on industry standards and have the tools and equipment to perform procedures safely and properly.



STEP-BY-STEP INSTRUCTIONS:

AIR SPRING REPLACEMENT MANUAL



# Glaval Titan II LF Bus

Replacement of Air Springs

Link Kit 800M0267

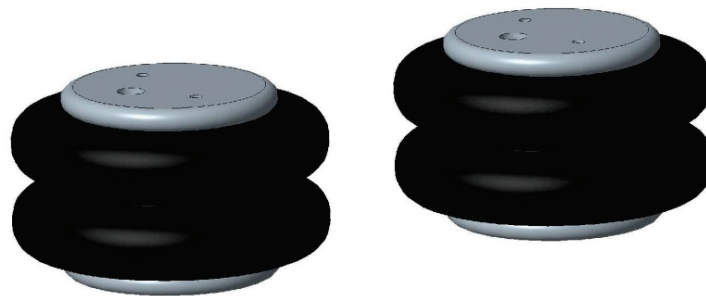

For Replacing Air Springs in Link Suspension 8M000133  
Part of Glaval's Titan II LF Bus

80003360  
JAN 18, 2017

Service Bulletins are intended for use by Professional Technicians only. They are written to guide Professional Technicians in performing service to vehicles of specific nature in conjunction with industry standards. Professional Technicians should be appropriately trained on industry standards and have the tools and equipment to perform procedures safely and properly.



Read this manual before replacing Air Springs in your UltraRide® suspension.



223 15th Street N.E.  
Sioux Center, Iowa 51250

For questions with your UltraRide suspension, please contact us toll free at (800) 222-6283

Visit [www.LinkMfg.com](http://www.LinkMfg.com)





## INTRODUCTION

All information in this manual is based on the latest information available at the time of printing. Link Manufacturing reserves the right to change its products or manuals at any time without notice. Contact Link at (800) 222-6283 for information on recent changes to products.

Damaged components should be returned to Link with a pre-arranged Returned Goods Authorization (RGA) number through the Customer Service Department. The damaged component may then be replaced if in compliance with warranty conditions.

**No alterations of any Link component is permitted without proper authorization from qualified Link personnel.**

## SAFETY SYMBOLS and TORQUE SYMBOL

	This is the safety alert symbol. It is used to alert you to potential personal injury hazards. Obey all safety messages that follow this symbol to avoid possible injury or death.	 CAUTION	CAUTION indicates a potentially hazardous situation which, if not avoided, could result in minor or moderate injury.
 WARNING	WARNING indicates a potentially hazardous situation which, if not avoided, could result in death or serious injury.		The torque symbol alerts you to tighten fasteners to a specified torque value.

Service Bulletins are intended for use by Professional Technicians only. They are written to guide Professional Technicians in performing service to vehicles of specific nature in conjunction with industry standards. Professional Technicians should be appropriately trained on industry standards and have the tools and equipment to perform procedures safely and properly.



# AIR SPRING REPLACEMENT

**IMPORTANT! Save all fasteners unless directed to discard them.  
Most fasteners will be reused.**

This procedure requires torque tools and either a vehicle lift and jack stands or a floor jack (refer to Figure 2 for required torque values).

## 1. Removal of the Air Springs

- Apply the parking brake. Lift the vehicle up to a comfortable working height. Lower the vehicle onto jack stands. If a vehicle lift is not available, jack up the front of the vehicle so the wheels are just touching the ground.

**⚠ CAUTION**

The vehicle lift can damage the body due to the low ground clearance. Use caution when rolling vehicle lifts under wheels.

**⚠ WARNING**

**Serious injury** could occur if components are removed and the vehicle is not well supported. Prior to removing components, make sure the vehicle is secure in the lift and the parking brake is applied.

- To remove air pressure from the springs, first locate the suspension manifold block, located on the driver side frame rail towards the rear of the vehicle.
- Drain the air pressure from the front springs using the Schrader valve at port C of the manifold block.
- After draining air, remove the Schrader valve from port C to relieve any residual pressure. Reinstall the Schrader valve immediately after relieving pressure.

**⚠ WARNING**

**Serious injury** could occur if components are removed while the air system is pressurized. If maintenance or service is to be done on the suspension, be sure to drain **all** air from system.

Refer to vehicle air system instructions for more information regarding air system controls.

- Remove the front wheels.
- On the driver side, remove the height control sensor arm from the linkage.
- Remove the three bolts and lock washers holding the air spring to the lower control arm.
- Remove the airline from the air spring fitting.
- Remove the two bolts connecting the air spring to the spring tower.
- Compress the air spring by hand and remove the air spring from the suspension.
- Repeat procedure for the passenger side.

Service Bulletins are intended for use by Professional Technicians only. They are written to guide Professional Technicians in performing service to vehicles of specific nature in conjunction with industry standards. Professional Technicians should be appropriately trained on industry standards and have the tools and equipment to perform procedures safely and properly.



## AIR SPRING REPLACEMENT

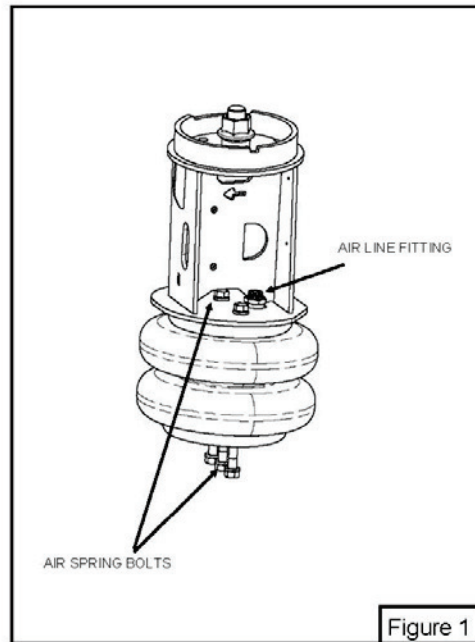

### 2. Installation of Air Springs

- Remove the air fitting from the old air spring. Properly discard the old air spring.
- Apply new thread sealant to the air fitting and install on the new air spring.
- Loosely install the air spring on the tower using the two bolts removed earlier.
- Connect the air line to the air spring fitting.
- Loosely attach the air spring to the lower control arm using the bolts and lock washers removed earlier.
- Attach the height control sensor arm to the linkage using the bolt removed earlier.
- Torque all suspension fasteners to the values specified on Figure 2.
- Install wheel/tire assembly and torque to 140 lb-ft.

### **WARNING**

**Proper fastener torque is vital to prevent component failures which may result in injury or death.**



# AIR SPRING REPLACEMENT

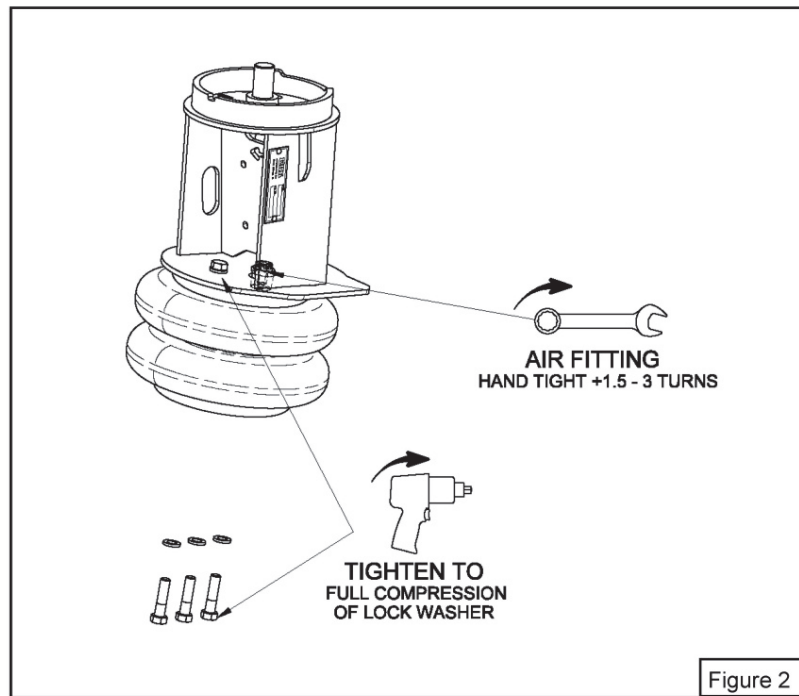

### 3. Verify Proper Installation and Function

- Verify all fasteners have been torqued properly.
- Check ride height is correct using the shock bolts as a reference point (see Figure 3 below).
- Check for leaks at the air spring fitting connection and at the valve block Schrader valve.
- It is recommended the vehicle be cycled to the kneeled (lowered) height once before operation to ensure proper operation.

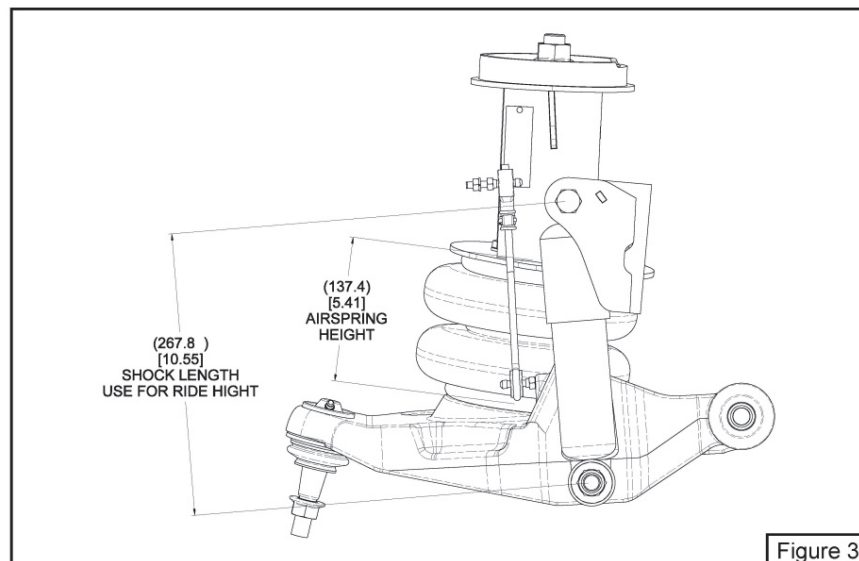

Service Bulletins are intended for use by Professional Technicians only. They are written to guide Professional Technicians in performing service to vehicles of specific nature in conjunction with industry standards. Professional Technicians should be appropriately trained on industry standards and have the tools and equipment to perform procedures safely and properly.



# 800M0267 PARTS LIST

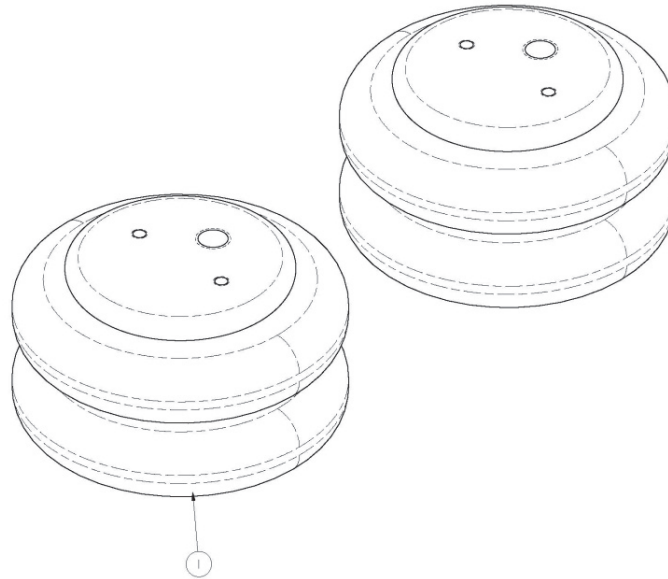

ITEM	PART NUMBER	DESCRIPTION	QTY
1	11030517	SPRING-AIR	2

Service Bulletins are intended for use by Professional Technicians only. They are written to guide Professional Technicians in performing service to vehicles of specific nature in conjunction with industry standards. Professional Technicians should be appropriately trained on industry standards and have the tools and equipment to perform procedures safely and properly.



Link Mfg. Ltd.  
223 15th St. NE  
Sioux Center, IA USA  
51250-2120

(712) 722-4874

<http://www.linkmfg.com/>

7

Service Bulletins are intended for use by Professional Technicians only. They are written to guide Professional Technicians in performing service to vehicles of specific nature in conjunction with industry standards. Professional Technicians should be appropriately trained on industry standards and have the tools and equipment to perform procedures safely and properly.