

Date: 05.01.2017
Model: Evora 400
Number: 2017/02

Copy files should be maintained by:

Service Manager	Service Reception	Lotus Technicians	Parts Manager	
-----------------	-------------------	-------------------	---------------	--

TITLE:

Confirmation of alternator fitted to the Evora 400 by amperage rating.

REASON:

Because of the revised electrical systems and subsequent increased demands placed on the vehicle battery on the Evora 400 as compared to the previous Evora N/A & S models, the 100 Amp rated alternator originally fitted has been replaced with an uprated 150 amp version as a production running change to ensure consistent battery performance.

The uprated alternator is initially being fitted to vehicles destined for 'Hot' market countries where the vehicle battery is subjected to higher electrical loading because of components such as the radiator coolant, HVAC and engine bay fans etc, operating for longer time durations as compared to vehicles located in more temperate climate zones.

Note: At the time of bulletin publication it is intended to fit the 150 amp alternator to all Evora and Exige V6 models as a production running change at a later date, regardless of the market the vehicle is destined for.



ACTION:

If alternator replacement is required on an Evora 400, then the amperage rating of the existing alternator must be identified to ensure that the correct part is ordered.

Alternator identification

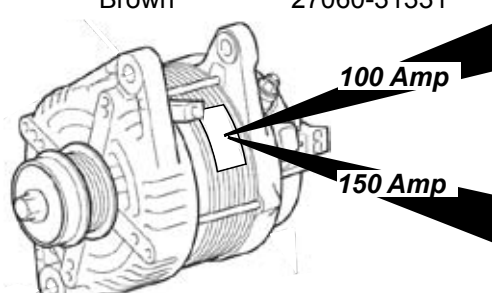
The amperage rating is not displayed on the alternator, but the manufacturers label attached to the exterior of the coil casing will identify the unit by label colour and manufacturers part number.

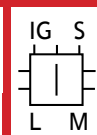
Alternator rating	Label colour	Toyota Part Number	Alternator identification label
100 amp	Red	27060-31082	
150 amp	Brown	27060-31331	

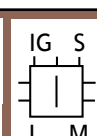
 TOYOTA 27060-31082 DENSO 104210-2074 3 1 0 7 0 12V <small>MADE IN JAPAN</small>	 IG S L M
 TOYOTA 27060-31331 DENSO 104211-8462 2 0 0 9 1 12V <small>MADE IN JAPAN</small>	 IG S L M

The alternator label may be viewed once the bulkhead access panel has been removed from the bulkhead trim panel.

CHARGES:

No warranty charges are associated with the contents of this bulletin.

Ends

LOTUS CARS LIMITED