



N26 ENGINE THERMOSTAT: LIMITED WARRANTY EXTENSION TO 10 YEARS/120,000 MILES FOR “NON-CALIFORNIA EMISSION” STATUTE STATES

What's New:

- Applicable N26 Engine Models added December 2017 in conjunction with the expansion of the existing N20 Engine Thermostat Extended Limited Warranty coverage (SI [01 01 16](#)).

MODEL

F22 (228i) Model Year 2015 produced 10/18/2014 to 1/31/2015	F22 (128i xDrive) Model Year 2015 produced 10/20/2014 to 1/31/2015	F30 (328i) Model Years 2014, 2015 and 2016 produced 3/1/2014 to 1/31/2015	F30 (328i xDrive) Model Years 2014, 2015 and 2016 produced 3/1/2014 to 1/31/2015
F32 (428i) Model Years 2014 and 2015 produced 3/3/2014 to 1/30/2015	F32 (428i xDrive) Model Years 2014 and 2015 produced 3/7/2014 to 1/30/2015	F33 (428i) Model Years 2014 and 2015 produced 3/3/2014 to 1/31/2015	F33 (428i xDrive) Model Years 2014, and 2015 produced 6/11/2014 to 1/30/2015
F34 (328i xDrive) Model Year 2015 produced 6/11/2014 to 1/30/2015	F36 (428i) Model Year 2015 produced 4/22/2014 to 1/30/2015	F36 (428i xDrive) Model Year 2015 produced 4/22/2014 to 1/30/2015	With the N26 PZEV (SULEV) engine

For vehicles **not registered** in the State of California or a State that fully adopted the “State of California PZEV (SULEV) regulation.”



Note: This limited warranty extension only applies to the vehicles listed above that were

produced up to and including 1/30/2015 or 1/31/2015 as applicable.

The “Model” information above is for informational purposes only, it is not the only deciding factor.

To determine vehicle eligibility and that this coverage applies, always perform a VIN-specific DCSnet Warranty Inquiry first

Please refer to the “Eligible Vehicles” section of this bulletin for further details.

INFORMATION

For the eligible vehicles, BMW of North America, LLC (“BMW NA”) is extending the limited warranty for the vehicle’s **engine thermostat** to:

- **10 years/120,000 miles as determined by the vehicle’s original in-service date**

This “component-specific” limited warranty extension applies to:

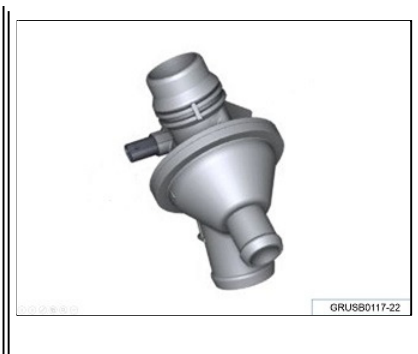

- This “component-specific” limited warranty extension applies to defects in materials or workmanship.
- This coverage is subject to the same vehicle eligibility requirements, limitations, and exclusions that apply to the BMW New Vehicle Limited Warranty for Passenger Cars and Light Trucks.



Note: This bulletin is a notice of a component-specific “limited warranty extension. This is **NOT** a notice of a Recall or Service Action.

There is no immediate repair required unless the BMW vehicle is currently experiencing this problem.

Customer Notification Letter

Even though this is **NOT** a Recall, BMW NA will be sending VIN-specific customer notification letters in a phased release.

ELIGIBLE VEHICLES

To assist you in identifying those vehicles that have this “component-specific” extended limited warranty coverage, the DCSnet Warranty Vehicle Inquiry has been updated with the VIN and Component-specific “Vehicle Comment” shown below:

For this vehicle, the N26 engine thermostat’s limited warranty for defects in materials or workmanship has been extended to 10 year/120,000 mile as determined from the original in-service date. This coverage is subject to the same vehicle eligibility requirements, limitations, and exclusions that apply to the BMW New Vehicle Limited Warranty, see SI [B01 17 17](#) (DC 11 53 90 01 00). If this vehicle is registered in California (CA) or another State that Fully Adopted the CA PZEV (SULEV) Regulation, qualifying thermostat repairs are covered for 15 years/150,000 miles.



Note: Before performing a repair and submitting a claim, first confirm that the vehicle has the above

“Notice of Limited Warranty Extension” in the DCSnet Warranty Inquiry “Vehicle Comments” section.

Please do not use a vehicle’s production date as the sole determinate for this coverage, the vehicle’s “model year” is also an important determinate.

If you have ELW eligibility and/or coverage question, please contact the Warranty department through IDS by selecting “Coverage, Policy and Coding” prior to performing any repairs.

PARTS INFORMATION



Note: Please refer to the Electronic Parts Catalog (ETK/EPC), using the customer’s VIN to

locate the applicable replacement part numbers.

- Only order these parts **in the quantities needed** to address customers' vehicles that have confirmed failures.
- **“Only in conjunction with” parts:** When applicable, if ETK/EPC item identifies additional part(s) that must also be replaced/installed “in-conjunction” with performing a covered repair, these “required” additional items are also covered under the terms of this extended limited warranty.
- Also refer to ETK/EPC and the repair instructions for onetime-use fasteners/screws and other information regarding repair-related gaskets, seals, fluid and/or lubricants that also need to be replaced/used and claimed.

Bulk Materials

Part Number	Description	Quantity
82 14 1 467 704	Antifreeze (One Gallon)	Sublet, see below

WARRANTY INFORMATION

“N26 engine” equipped vehicles listed in this bulletin that are **registered** in California or a State that “fully adopted” the “State of California PZEV/SULEV regulation” (model year dependent), the **engine thermostat** is covered by the terms of the California Emissions Warranty for 15 years/150,000 miles. Please see the “By State” coverage information section below.

“N26 engine” equipped vehicles listed in this bulletin that are **not registered** in the State of California or a State that fully adopted the “State of California PZEV/SULEV regulation,” The **engine thermostat** limited warranty has been extension to 10 years/120,000 miles.

This coverage applies to “eligible US-specification BMW vehicles” that are registered, operated and have their covered repair performed by an authorized BMW center in the United States (including Puerto Rico).

This coverage supersedes the coverage that is provided under the BMW Certified Pre-Owned Program or any BMW Group Vehicle Service Contract that applies to the vehicle.

The existing limited warranty coverage for the whole vehicle and other components has not changed.

Should engine thermostat fail again, this component is covered by the remaining portion of the extended limited warranty coverage period.

Non-Qualifying Repairs

Non-US specification vehicles, ineligible vehicles, eligible vehicles operated and repaired outside the United States and Puerto Rico and/or the diagnosis and repair of other unrelated issues are not covered under the terms of this limited warranty extension.

Qualifying Repairs - Claim Submission

Claim this work with the defect code and labor operations provided below.

Defect Code:	1153900100	
---------------------	-------------------	--

Vehicles with Fault Code Stored/MIL (Check Engine) Light Illuminated

Labor Operation:	Labor Allowance:	Description:
00 00 006	Refer to KSD2	Performing “vehicle test” (with vehicle diagnosis system – checking faults) (Main work)

Or:		
00 00 556	Refer to KSD2	Performing "vehicle test" (with vehicle diagnosis system – checking faults) (Plus work)
And:		
61 21 528	Refer to KSD2	Connect an approved battery charger/power supply (indicated in KSD2 as "Charging battery")
And:		
61 00 006	Work time (WT)	Performing vehicle diagnosis – test module
And:		
11 53 500	Refer to KSD2	Removing and installing/replacing coolant thermostat
Or:		
11 53 700	Refer to KSD2	Removing and installing/replacing coolant thermostat (Coolant already drained to perform another repair)

If you are using a Main labor code for another repair, use the Plus code labor operation 00 00 556 instead of 00 00 0006.

Work time labor operation code 61 00 006 is not considered a Main labor operation; however, it does require an individual punch time and an explanation on the repair order and in the claim comments section.

And, for all vehicles:

Sublet – Bulk Materials

Sublet Code 4	See sublet reimbursement calculation below	Reimbursement for replacing the drained quantity of antifreeze/coolant (Bulk container reference P/N 82 14 1 467 704, one gallon container). Please do not use this part number for claim submission.
---------------	--	---

Sublet calculation: BMW antifreeze/coolant (Bulk container reference P/N 82 14 1 467 704) for replacing the drained quantity (50/50 mixture) at dealer net plus handling.

Enter the material cost in sublet and itemize the amount on the repair order and in the claim comment section.

A. CALIFORNIA (CA 15/150) PZEV (SULEV) REGULATION

N26 engine thermostat 15 year/150,000 mile coverage applies in California as follows:

State	CA 15/150 starts with:	MY 2014	MY 2015
California	MY 2003	F30, F32, F33	F22, F30, F32, F33, F34, F36

B. OTHER STATES THAT FULLY ADOPTED THE CA 15/150 PZEV (SULEV) REGULATION

N26 engine thermostat 15 year/150,000 mile coverage also applies in the following states:

State	CA 15/150 starts with:	MY 2014	MY 2015
Arizona	MY 2012 Only	N/A	N/A
Connecticut	MY 2007	F30, F32, F33	F22, F30, F32, F33, F34, F36
Maine	MY 2004	F30, F32, F33	F22, F30, F32, F33, F34, F36
Maryland	MY 2011	F30, F32, F33	F22, F30, F32, F33, F34, F36
Massachusetts	MY 2004	F30, F32, F33	F22, F30, F32, F33, F34, F36
New Jersey	MY 2009	F30, F32, F33	F22, F30, F32, F33, F34, F36
New Mexico	MY 2011 Only	N/A	N/A
New York	MY 2003	F30, F32, F33	F22, F30, F32, F33, F34, F36
Rhode Island	MY 2008	F30, F32, F33	F22, F30, F32, F33, F34, F36
Vermont	MY 2004	F30, F32, F33	F22, F30, F32, F33, F34, F36



For these vehicles (A and B), claim the qualifying N26 engine thermostat repair using the applicable

defect code and labor operations listed in KSD2/AIR.

C. STATES THAT PARTIALLY ADOPTED THE CA REGULATION

The following States **partially adopted** the “State of California PZEV (SULEV) regulation” by excluding the 15/150 coverage.

For vehicles registered in these four states, the N26 engine thermostat coverage that applies is the following:

States	CA 3/50 starts with:	New Vehicle Ltd Wty	Extended Ltd Wty
Delaware	MY 2014	Apr-50	10/120
Oregon	MY 2008	Apr-50	10/120
Pennsylvania	MY 2009	Apr-50	10/120
Washington	MY 2008	Apr-50	10/120

Overlapping Labor Procedure – Other Repairs

If invoicing the KSD2 flat rate labor operation codes for other repair work results in overlapping labor, for those flat rate labor operations that are affected, you can now:

- Replace the stated KSD2 “FRU allowance” with a “reduced FRU value” to eliminate the overlapping labor.

For help in identifying the overlapping labor, please refer to the AIR FRU Plausibility Check (Overlapping Labor Tool) that is located in the AIR Client.

Eligible other repair work being claimed under a different defect code will require separate punch times.

On the repair order and in the claim comment section, please identify and itemize those labor operations being claimed with a “reduced FRU value.”

Previous Customer-pay Repairs – Limited Warranty Extension Reimbursement

For the “Models” listed above and under this extended limited warranty, BMW of North America, LLC (“BMW NA”) will provide reimbursement for “qualifying customer-pay repairs” that were performed on an eligible vehicle **prior** to the release of this component-specific limited warranty extension.

Customer-pay repairs are subject to the same vehicle eligibility requirements, limitations, and exclusions that apply to the BMW New Vehicle Limited Warranty for Passenger Cars and Light Trucks.

Repairs that do not Qualify for Reimbursement

Repairs performed on ineligible vehicles, eligible vehicles operated and repaired outside the United States and Puerto Rico and/or the diagnosis and repair of other unrelated issues. This exclusion applies to repairs, including consequential, that were performed using non-genuine BMW parts and/or used passenger car or light truck parts.

Requesting Reimbursement for a Previous Repair that Qualifies

For a customer to request reimbursement for a “qualifying customer-pay repair” performed either by an authorized BMW center or independent repair shop located in the United States (including Puerto Rico), please have him/her submit his/her reimbursement request “online” at www.BMW-RP.com under the following reference:

- **B-ELWR 2016 N26 Engine Thermostat 10Y120M**

Reimbursement Request Procedure

The online process is initiated by attaching/sending “PDF files” of the supporting documentation for the “prior repair.”

The website and attached sample customer letter provides information as to “what” documentation is needed to be supplied to support a prior repair.

The letter also includes alternative methods to request reimbursement, either through the mail or by fax as described below:

BMW Customer Reimbursement Center
Attention: B-ELWR 2016 N26 Engine Thermostat 10Y120M
P.O. Box 561089
Dallas, Texas 75356

Fax number: 877-434-2992

Please allow 4-6 weeks for processing your request.

Should you have any questions concerning this reimbursement process, please call 1-844-857-0341.

BMW Owner/Operator Inquiries and Assistance

For all other questions, please contact the BMW’s Customer Relations and Services via email at Customerrelations@bmwusa.com or via telephone at 1-800-831-1117.

Please have your 17-character Vehicle Identification Number (VIN) available and include the VIN with all communications.

Wednesday, January 10, 2018

ATTACHMENTS

View PDF attachment [B011717 N26 Thermostat Sample Customer Letter](#).

[Copyright ©2017 BMW of North America, Inc.]

Month YYYY

This **“Important Limited Warranty Information”** applies to the BMW vehicle with the Vehicle Identification Number (VIN) of **WBANB535X01234567**.

Dear BMW Owner/Lessee:

BMW is committed to delivering the ultimate in product satisfaction to our customers.

Towards that end, BMW is extending the limited warranty for the:

- **“Engine Thermostat”**

On the above-referenced vehicle to:

- **10 years/120,000 miles as determined by your vehicle’s original in-service date.**

This “component-specific” limited warranty extensions apply to defects in materials or workmanship. This coverage is subject to the same vehicle eligibility requirements, limitations, and exclusions that apply to the BMW New Vehicle Limited Warranty for Passenger Cars and Light Trucks.

This is notice of a “limited warranty extension.” This is not a notice of a Recall or Service Action.

If a repair to this component is required, please contact your nearest authorized BMW center in the United States or Puerto Rico to schedule an appointment. Your authorized BMW center will determine the vehicle’s eligibility and review the scope of repairs that are covered by this component-specific limited warranty extension(s).

After vehicle inspection and diagnosis, eligible repair work will be performed by the authorized BMW center in the United States (including Puerto Rico) free of charge.

Repairs performed on ineligible vehicles, eligible vehicles operated and repaired outside the United States and Puerto Rico and/or the diagnosis and repair of other unrelated issues are not covered by this limited warranty extension. This exclusion applies to repairs, including consequential, that were performed using non-genuine BMW parts and/or used passenger car or light truck parts.

The integrity of our products is essential to BMW’s success and our customers’ trust. We are determined to exceed your expectations and hope this warranty extension further enhances your ownership experience.

Sincerely,

BMW of North America, LLC

Previous Customer-pay Repairs – Limited Warranty Extension Reimbursement

BMW of North America, LLC

Month YYYY

VIN WBANB535X01234567

Under these extended limited warranties, BMW of North America, LLC (“BMW NA”) will provide reimbursement for “qualifying customer-pay repairs” that were performed on an eligible vehicle **prior** to the release of these component-specific limited warranty extensions.

Customer-pay repairs are subject to the applicable vehicle and coverage eligibility requirements, exclusions and limitations that apply to the BMW New Vehicle Limited Warranty for Passenger Cars and Light Trucks.

Repairs that do not Qualify for Reimbursement

Repairs performed on ineligible vehicles, eligible vehicles operated and repaired outside the United States and Puerto Rico and/or the diagnosis and repair of other unrelated issues. This exclusion applies to repairs, including consequential, that were performed using non-genuine BMW parts and/or used passenger car or light truck parts.

Requesting Reimbursement for a Previous Repair that Qualifies

If you previously had a “qualifying customer-pay repair” performed either by an authorized BMW center or independent repair shop located in the United States (including Puerto Rico), please submit your reimbursement request “online” at www.BMW-RP.com under the following reference:

Covered Component Code

B-ELWR 2017 N26 Engine Thermostat 10Y120M

To initiate the online process, you will be asked to attach PDF files of the required documentation as outlined in the reimbursement checklist on the next page.

Alternative Method to Request Reimbursement

Alternatively, you may mail or fax your request and documentation to:

BMW Customer Reimbursement Center
Attention: B-ELWR 2017 N26 Engine Thermostat 10Y120M
P.O. Box 561089
Dallas, TX 75356
Fax number: 877-434-2992

Please allow 4-6 weeks for processing your request.

Should you have any questions concerning this reimbursement process, please call 1-844-857-0341.

For all other questions, please contact BMW’s Customer Relations and Services via email at Customerrelations@bmwusa.com or via telephone at 1-800-831-1117.

Please have your 17-character Vehicle Identification Number (VIN) available and include the VIN with all communications.

N26 Thermostat: Limited Warranty Extension to 10 Years/120,000 Miles

Previous Customer-pay Repair Reimbursement – Documentation Checklist

BMW of North America, LLC

Reimbursement is available to the BMW Owner/Lessee who incurred the expense.

When submitting a reimbursement for a previous repair, please provide **legible copies** of the following documentation and include your VIN, name, address and your preferred contact telephone number(s):

Repair Order (RO) or Invoice

This document should include the following information:

- Customer name and address
- Vehicle Identification Number (“VIN”)
- The date of repair
- The mileage when the repair was performed
- Itemized breakdown of the labor charges for all repairs* including diagnosis
- Itemized breakdown of the parts, including any miscellaneous items, billed for all repairs*

*For repair orders containing multiple repair line items, only the specific line item expenses that relate to the component that is covered by this extended limited warranty will be considered for reimbursement.

Proof of Payment

Please provide a copy of at least **one** of the following items as valid proof of payment:

- Repair order (RO)/invoice stamped and dated as “PAID”
- Copy of a cancelled check
- Copy of a signed credit/debit card receipt
- Copy of a credit/debit card statement

Determining if an eligible vehicle’s repair qualifies for reimbursement:

Please use the following questions to review your repair order documentation prior to submitting a reimbursement request:

1. Why was the vehicle brought into the repair facility?
2. What was the repair facility's diagnosis?
3. What did the repair facility do to correct the concern and does it qualify?