

November 2017
FL731A-G
NHTSA #17V-043
Transport Canada #17-031
SECOND REVISED NOTICE

Subject: ICU3S Dual Cluster Displays

Models Affected: Specific Freightliner 108SD, 114SD, and Business Class M2 vehicles manufactured March 5, 2015, through August 15, 2016.

General Information

Daimler Trucks North America LLC (DTNA), on behalf of its Freightliner Trucks Division, has decided that a defect that relates to motor vehicle safety exists on the vehicles mentioned above.

There are approximately 855 vehicles involved in this campaign.

On certain vehicles, hardware and software incompatibilities between the right and left hand dash cluster displays may result in the left hand ICU3S becoming completely unresponsive until all power is removed. If the ICU3S becomes unresponsive, the turn signals may not function which could lead to a vehicle crash.

The ICU3S dash clusters will be replaced with new dash clusters.

REVISIONS:The work instructions now specify the suspect ICU3 cluster to be the driver side cluster. The part numbers for groups FL731-E and FL731-F were inadvertently swapped in the Replacement Parts Table and have been corrected. The SRTs have been updated to the new format with an "R" in the fifth position.

NOTE: The Time Allowed for both the Inspect and Replacement procedures were incorrectly entered into the original Labor Allowance table. These times were changed to reflect the correct allowance.

Additional Repairs

Dealers must complete all outstanding Recall and Field Service campaigns prior to the sale or delivery of a vehicle. A Dealer will be liable for any progressive damage that results from its failure to complete campaigns before sale or delivery of a vehicle.

Owners may be liable for any progressive damage that results from failure to complete campaigns within a reasonable time after receiving notification.

Work Instructions

Please refer to the attached work instructions. Prior to performing the campaign, check the vehicle for a completion sticker (Form WAR260).

Replacement Parts

Replacement parts are now available and can be obtained by ordering the kit or part number(s) listed below from your facing Parts Distribution Center.

If our records show your dealership has ordered any vehicles involved in campaign number FL731, a list of the customers and vehicle identification numbers will be available in OWL. Please refer to this list when ordering parts for this recall.

November 2017
FL731A-G
NHTSA #17V-043
Transport Canada #17-031
SECOND REVISED NOTICE

Table 1 - Replacement Parts for FL731

Campaign Number	Part Description	Part Number	Qty. Per Vehicle
FL731A (665 VINs)	CLUSTER-SERVICE,ICU3S-M2,US,TRANS,2A	VDO A2C1144170096	1 ea
FL731B (71 VINs)	SERVICE CLUSTER-ICU3S-M2,US,2 AIR	VDO A2C1144160096	1 ea
FL731C (68 VINs)	CLUSTER-SERVICE,ICU3S-M2,NFT,TRAN,2A	VDO A2C1246190096	1 ea
FL731D (19 VINs)	CLST ASSY -ICU3S,M2,US,TR,2A,NG	VDO A2C1246370096	1 ea
FL731E (16 VINs)	CLUSTER-SERVICE,ICU3S-M2,NAFTA,2 AIR	VDO A2C1246390096	1 ea
FL731F (5 VINs)	CLUSTER-SERVICE,ICU3S-M2,NF,TR,2A,NG	VDO A2C1246180096	1 ea
FL731G (1 VIN)	CLUSTER-ASSY,ICU3S-M2,US,2A,NG-SERVICE	VDO A2C1246360096	1 ea
FL731A-G	COMPLETION STICKER	WAR260	1 ea

Table 1

Removed Parts

U.S. and Canadian Dealers, please follow Warranty Failed Parts Tracking shipping instructions for the disposition of all removed parts. Export distributors, please destroy removed parts unless otherwise advised.

Labor Allowance

Table 2 - Labor Allowance

Campaign Number	Procedure	Time Allowed (hours)	SRT Code	Corrective Action
FL731A-G	Inspect instrument cluster; no replacement needed	0.1	996-R001A	06-Inspect
	Inspect and replace instrument cluster	0.3	996-R001B	12-Repair Recall/Campaign

Table 2

IMPORTANT: When the Recall has been completed, locate the base completion label in the appropriate location on the vehicle, and attach the red completion sticker provided in the recall kit (Form WAR260). If the vehicle does not have a base completion label, clean a spot on the appropriate location of the vehicle and first attach the base completion label (Form WAR259). If a recall kit is not required or there is no completion sticker in the kit, write the recall number on a blank sticker and attach it to the base completion label.

Claims for Credit

You will be reimbursed for your parts, labor, and handling (landed cost for Export Distributors) by submitting your claim through the Warranty system within 30 days of completing this campaign. Please reference the following information in OWL:

REVISIONS:The work instructions now specify the suspect ICU3 cluster to be the driver side cluster. The part numbers for groups FL731-E and FL731-F were inadvertently swapped in the Replacement Parts Table, and have been corrected. The SRTs have been updated to the new format with an "R" in the fifth position.

NOTE: The Time Allowed for both the Inspect and Replacement procedures were incorrectly entered into the original Labor Allowance table. These times were changed to reflect the correct allowance.

November 2017
FL731A-G
NHTSA #17V-043
Transport Canada #17-031
SECOND REVISED NOTICE

- Claim type is **Recall**.
- In the FTL Authorization field, enter the campaign number and appropriate condition code (e.g. **FL731-A, FL731-B, etc.**).
- In the Primary Failed Part Number field, enter **25-FL731-000**.
- In the Parts field, enter the appropriate kit or part number(s) as shown in the Replacement Parts Table.
- In the Labor field, first enter the appropriate SRT from the Labor Allowance Table. Administrative time will be included automatically as SRT 939-0010A for 0.3 hours.
- The VMRS Component Code is **003-002-024** and the Cause Code is **A1 - Campaign**.
- **U.S. and Canada -- Reimbursement for Prior Repairs.** When a customer asks about reimbursement, please do the following:
 - Accept the documentation of the previous repair.
 - Make a brief check of the customer's paperwork to see if the repair may be eligible for reimbursement. (See the "Copy of Owner Letter" section of this bulletin for reimbursement guidelines.)
 - Submit an OWL Recall Pre-Approval Request for a decision.
 - Include the approved amount on your claim in the Other Charges section.
 - Attach the documentation to the pre-approval request.
 - If approved, submit a based on claim for the pre-approval.
 - Reimburse the customer the appropriate amount.

IMPORTANT: OWL must be viewed prior to performing the recall to ensure the vehicle is involved and the campaign has not been previously completed. Also, check for a completion sticker prior to beginning work.

U.S. and Canadian dealers, contact the Warranty Campaigns Department from 7:00 a.m. to 4:00 p.m. Pacific Time, Monday through Friday, via Web inquiry at DTNAConnect.com / WSC, or the Customer Assistance Center at (800) 385-4357, after normal business hours, if you have any questions or need additional information. Export distributors, submit a Web inquiry or contact your International Service Manager.

U.S. and Canadian Dealers: To return excess kit inventory related to this campaign, U.S. dealers must submit a Parts Authorization Return (PAR) to the Memphis PDC. Canadian dealers must submit a PAR to their facing PDC. All kits must be in resalable condition. PAR requests must include the original purchase invoice number. Export Distributors: Excess inventory is not returnable.

The letter notifying U.S. and Canadian vehicle owners is included for your reference.

Please note that the National Traffic and Motor Vehicle Safety Act, as amended (Title 49, United States Code, Chapter 301), requires the owner's vehicle(s) be corrected within a reasonable time after parts are available to you. The Act states that failure to repair a vehicle within 60 days after tender for repair shall be prima facie evidence of an unreasonable time. However, circumstances of a particular situation may reduce the 60 day period. Failure to repair a vehicle within a reasonable time can result in either the obligation to (a) replace the vehicle with an identical or reasonably equivalent vehicle, without charge, or (b) refund the purchase price in full, less a reasonable allowance for depreciation. The Act further prohibits dealers from selling a vehicle unless all outstanding recalls are performed. Any lessor is required to send a copy of the recall notification to the lessee within 10 days. Any subsequent stage manufacturer is required to forward this notice to its distributors and retail outlets within five working days.

November 2017
FL731A-G
NHTSA #17V-043
Transport Canada #17-031
SECOND REVISED NOTICE

Copy of Notice to Owners

Subject: ICU3S Dual Cluster Displays

For the Notice to U.S. Customers: This notice is sent to you in accordance with the National Traffic and Motor Vehicle Safety Act. **For the Notice to Canadian Customers:** This notice is sent to you in accordance with the Canadian Motor Vehicle Safety Act.

Daimler Trucks North America LLC (DTNA), on behalf of its Freightliner Trucks Division, has decided that a defect that relates to motor vehicle safety exists on specific Freightliner 108SD, 114SD, and Business Class M2 vehicles manufactured March 5, 2015, through August 15, 2016.

On certain vehicles, hardware and software incompatibilities between the right and left hand dash cluster displays may result in the left hand ICU3S becoming completely unresponsive until all power is removed. If the ICU3S becomes unresponsive, the turn signals may not function which could lead to a vehicle crash.

The ICU3S dash clusters will be replaced with new dash clusters.

This is the third of three notices mailed regarding this subject. **The final repair is ready and parts have been secured.** Please contact an authorized Daimler Trucks North America dealer to arrange to have the Recall performed and to ensure that parts are available at the dealership. To locate an authorized dealer, search online at www.Daimler-TrucksNorthAmerica.com / Contact Us / Find a Dealer. The Recall will take approximately half an hour and will be performed at no charge to you.

You may be liable for any progressive damage that results from your failure to complete the Recall within a reasonable time after receiving notification.

If you do not own the vehicle that corresponds to the identification number(s) which appears on the Recall Notification, please return the notification to the Warranty Campaigns Department with any information you can furnish that will assist us in locating the present owner. If you have leased this vehicle, Federal law requires that you forward this notice to the lessee within 10 days. If you are a subsequent stage manufacturer, Federal law requires that you forward this notice to your distributors and retail outlets within five working days. If you have paid to have this recall condition corrected prior to this notice, you may be eligible to receive reimbursement. Please see the reverse side of this notice for details.

For the Notice to U.S. Customers: If you have questions about this Recall, please contact the Warranty Campaigns Department at (800) 547-0712, 7:00 a.m. to 4:00 p.m. Pacific Time, Monday through Friday, e-mail address DTNA.Warranty.Campaigns@Daimler.com, or the Customer Assistance Center at (800) 385-4357 after normal business hours. If you are not able to have the defect remedied without charge and within a reasonable time, you may wish to submit a complaint to the Administrator, National Highway Traffic Safety Administration, 1200 New Jersey Avenue, SE., Washington, DC 20590; or call the Vehicle Safety Hotline at (888) 327-4236 (TTY: 800-424-9153); or to <http://www.safercar.gov>. **For the Notice to Canadian Customers:** If you have questions about this Recall, please contact the Warranty Campaigns Department at (800) 547-0712, 7:00 a.m. to 4:00 p.m. Pacific Time, Monday through Friday, e-mail address DTNA.Warranty.Campaigns@Daimler.com, or the Customer Assistance Center at (800) 385-4357 after normal business hours.

We regret any inconvenience this action may cause but feel certain you understand our interest in motor vehicle safety.

WARRANTY CAMPAIGNS DEPARTMENT

Enclosure

**November 2017
FL731A-G
NHTSA #17V-043
Transport Canada #17-031
SECOND REVISED NOTICE**

Reimbursement to Customers for Repairs Performed Prior to Recall

If you have already **paid** to have this recall condition corrected you may be eligible to receive reimbursement.

Requests for reimbursement may include parts and labor. Reimbursement may be limited to the amount the repair would have cost if completed by an authorized Daimler Trucks North America LLC dealer. The following documentation must be presented to your dealer for consideration for reimbursement.

Please provide original or clear copies of all receipts, invoices, and repair orders that show:

- The name and address of the person who paid for the repair
- The Vehicle Identification Number (VIN) of the vehicle that was repaired
- What problem occurred, what repair was done, when the repair was done
- Who repaired the vehicle
- The total cost of the repair expense that is being claimed
- Proof of payment for the repair (such as the front and back of a cancelled check or a credit card receipt)

Reimbursement will be made by check from your Daimler Trucks North America LLC dealer.

Please speak with your Daimler Trucks North America LLC authorized dealer concerning this matter.

November 2017
FL731A-G
NHTSA #17V-043
Transport Canada #17-031
SECOND REVISED NOTICE

Work Instructions

Subject: ICU3S Dual Cluster Displays

Models Affected: Specific Freightliner 108SD, 114SD, and Business Class M2 vehicles manufactured March 5, 2015, through August 15, 2016.

REVISIONS:The work instructions now specify the suspect ICU3 cluster to be the driver side cluster. The part numbers for groups FL731-E and FL731-F were inadvertently swapped in the Replacement Parts Table, and have been corrected. The SRTs have been updated to the new format with an "R" in the fifth position.

NOTE: The Time Allowed for both the Inspect and Replacement procedures were incorrectly entered into the original Labor Allowance table. These times were changed to reflect the correct allowance.

Work Instructions

1. Check the base label (Form WAR259) for a completion sticker for FL731 (Form WAR260) indicating this work has been completed. The base label is usually located on the passenger-side door, about 12 inches (30 cm) below the door latch. If a completion sticker is present, no work is needed. If a completion sticker is not present, proceed to the next step.
2. Park the vehicle, shut down the engine, and apply the parking brakes. Chock tires.
3. On the driver side ICU, press the ICU3S mode button until the software/hardware versions display on screen. Verify the software level of the ICU3S. See [Fig. 1](#) .

If the software level of the ICU3S is 1.3, or higher, no further action is necessary. Continue with step 19.

If the software level is below 1.3, continue with the next step.



Fig. 1, ICU3S Screen Showing Software Version 1.3 (correct)

4. Attach a sticker to the driver side door frame indicating the mileage from the driver display, and the date that the ICU3S is being replaced.
5. Disconnect all negative leads from the batteries.

WARNING

Air lines under pressure can whip dangerously if disconnected. Drain all air from the air tanks before disconnecting air lines. Disconnecting pressurized air lines can cause personal injury and/or property damage.

6. Discharge the air pressure from the primary and secondary air tanks.

November 2017
FL731A-G
NHTSA #17V-043
Transport Canada #17-031
SECOND REVISED NOTICE

- Remove the dash trim piece by removing the eleven screws that secure it to the dash. All fasteners for this procedure are 10–16 Torx® capscrews. See [Fig. 2](#).

NOTICE

Do not forcibly pull the ICU3S from the dash. This may dislodge electrical connections or air lines from the back of the ICU3S, causing damage to connections, lines, or the dash.

- Remove the four screws that secure the driver side ICU.
- Disconnect the two electrical connectors from the back of the ICU3S. See [Fig. 3](#).

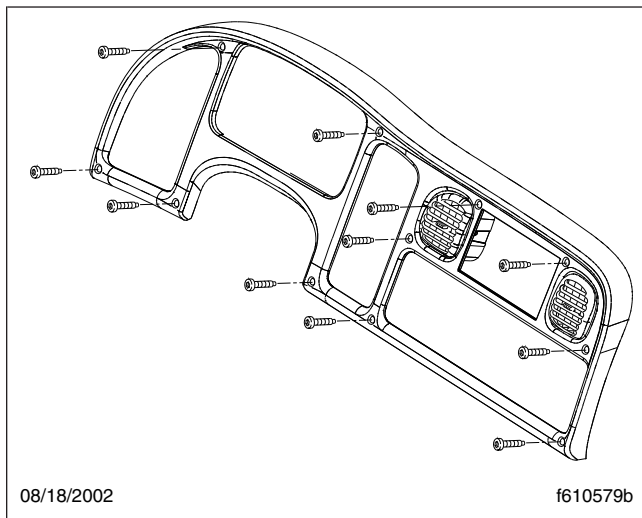

Fig. 2, Dash Trim Piece

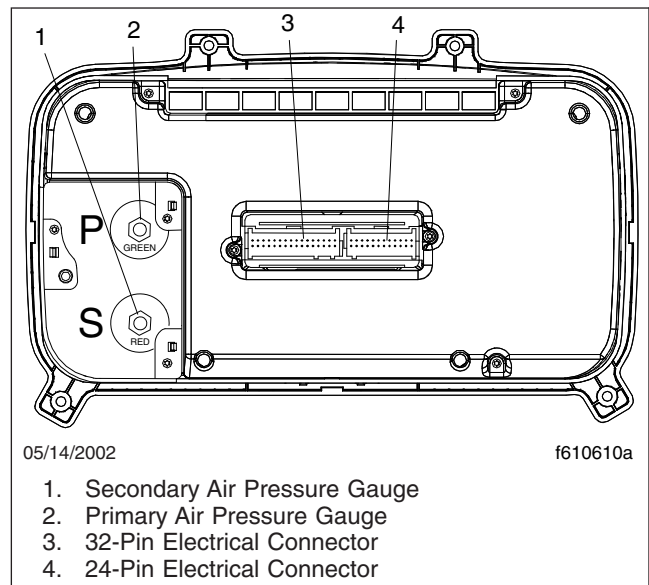

Fig. 3, ICU3S, Rear View

- Remove the air lines by pressing the push-lock connectors, then pulling the air lines away from the gauges. The lines are color-coded for ease of installation. The primary air line is green and is connected to the upper gauge. The secondary air line is red and is connected to the lower gauge.
 - Connect the air lines to the air gauges to the new ICU3S by pressing them firmly into the push-lock connector on the back of the gauge. The green air line connects to the primary (upper) gauge. The red air line connects to the secondary (lower) gauge.
 - Connect the electrical connectors to the back of the ICU3S.
 - Place the ICU3S in the dash opening and secure it with the four capscrews. Tighten the capscrews 30 lbf-in (340 N-cm).
 - Install the dash trim piece and secure it with eleven capscrews. Tighten the capscrews 30 lbf-in (340 N-cm).
 - Connect the batteries.
- NOTE: Mechanical (air) gauges do not make a sweep.
- Turn on the ignition and test the operation of the cluster. All electronic gauges should make one complete sweep and return to their normal indicating positions. The warning and indicator lights should turn on, then off.

**November 2017
FL731A-G
NHTSA #17V-043
Transport Canada #17-031
SECOND REVISED NOTICE**

17. Start the engine and verify proper operation of the air gauge module as the air pressure builds.
18. Verify the ICU3S software version. Press the mode button on the ICU until the software/hardware versions display on screen, and make sure that the software level of the ICU3S is 1.3, or higher.
19. Clean a spot on the base label (Form WAR259). Write the campaign number, FL731, on a blank red completion sticker (Form WAR260) to indicate the work has been completed and attach it to the base label.