

April 2017
FL724A-Q
NHTSA #16V-666 (Non-School Buses)
NHTSA #16V-664 (School Buses)
SECOND REVISED NOTICE

Subject: ICU3S Instrument Cluster Hydraulic Brake Telltale

Models Affected: Specific Freightliner Business Class M2 vehicles and Freightliner Custom Chassis S2 bus and B2 (Thomas Built Buses C2 Saf-T-Liner) school bus chassis manufactured March 3, 2015, through September 8, 2016.

General Information

Daimler Trucks North America LLC (DTNA), on behalf of its Freightliner Trucks Division and its wholly owned subsidiary, Freightliner Custom Chassis Corporation, has decided that a non-compliance with Federal Motor Vehicle Safety Standards (FMVSS) exists on the vehicles mentioned above.

There are approximately 4,500 vehicles involved in this campaign.

On certain hydraulic braked vehicles with ICU3s instrument clusters, the telltale for a brake malfunction says "PARK" instead of "BRAKE," as required by FMVSS 101 (Controls and Displays) and FMVSS 105 (Hydraulic and Electric Brake Systems). If "PARK" is illuminated instead of "BRAKE," the driver may not be aware there is a brake malfunction that could lead to a reduction or loss of braking, resulting in a possible vehicle crash.

The instrument clusters will be inspected and replaced with clusters displaying the correct warning as needed.

IMPORTANT: Advance arrangements are required for buses, as the new instrument clusters are individually programmed for each vehicle. Advance arrangements are recommended for the trucks to be sure that the appropriate new instrument cluster is available when the customer arrives.

REVISIONS: The replacement part number for some groups in Table 1 below were incorrect. The table has been updated. Step 12 (applies to trucks only) has been expanded to emphasize that telltale carriers/cartridges stay on the same side as they are moved from the old to the new instrument cluster.

Additional Repairs

Dealers must complete all outstanding Recall and Field Service campaigns prior to the sale or delivery of a vehicle. A Dealer will be liable for any progressive damage that results from its failure to complete campaigns before sale or delivery of a vehicle.

Owners may be liable for any progressive damage that results from failure to complete campaigns within a reasonable time after receiving notification.

Work Instructions

Please refer to the attached work instructions. Prior to performing the campaign, check the vehicle for a completion sticker (Form WAR260).

Replacement Parts

Replacement parts are now available and can be obtained by ordering the kit or part number(s) listed below from your facing Parts Distribution Center.

If our records show your dealership has ordered any vehicles involved in campaign number FL724, a list of the customers and vehicle identification numbers will be available in OWL. Please refer to this list when ordering parts for this recall.

NOTE: Order new instrument clusters for Freightliner Business Class M2 vehicles in groups FL724-A through FL724-H as noted in Table 1 below. The telltale cartridges will be moved from the existing cluster to the new ICU3s cluster. New instrument clusters for the Freightliner Custom Chassis bus chassis in groups FL724-I through FL724-Q will be completely pre-programmed and must be ordered by vehicle serial, part numbers are also in **Table 1**

April 2017
FL724A-Q
NHTSA #16V-666 (Non-School Buses)
NHTSA #16V-664 (School Buses)
SECOND REVISED NOTICE

Table 1 - Replacement Parts for FL724

Campaign Number	Part Number	Part Description	Qty. per Vehicle
FL724-A	VDO A2C1144200096	CLUSTER-ASSY,ICU3S-M2,HB,US,SERVICE	1 ea
FL724-B	VDO A2C1246280096	CLUSTER-ASSY,ICU3S-M2,HB,US,SERVICE	1 ea
FL724-C	VDO A2C1144210096	CLUSTER-ASSY,ICU3S-M2,HB,US,TRANS, SRVCE	1 ea
FL724-D	VDO A2C1144230096	CLUSTER-ASSY,ICU3S-M2,HB,US,TRN,A,SERVIC	1 ea
FL724-E	VDO A2C1246290096	CLUSTER-ASSY,ICU3S-M2,HB,US,TRAN,SERVICE	1 ea
FL724-F	VDO A2C1144220096	CLUSTER-ASSY,ICU3S-M2,HB,US,AIR,SERVICE	1 ea
FL724-G	VDO A2C1246310096	CLUSTER-ASSY,ICU3S-M2,HB,US,TRN,A,SRVCE	1 ea
FL724-H	VDO A2C1246300096	CLUSTER-ASSY,ICU3S-M2,HB,US,AIR,SERVICE	1 ea
FL724-I	A22-74544-003	CLUSTER-ICU3S,US,TRAN,HYD	1 ea
FL724-J and O	A22-74544-000	CLUSTER-ICU3S,US,HYD	1 ea
FL724-K and P	A22-74544-004	CLUSTER-ICU3S,US,TRAN,HYD/AIR	1 ea
FL724-L and Q	A22-74544-001	CLUSTER-ICU3S,US,HYD/AIR	1 ea
FL724-M	A22-74613-003	CLUSTER-ICU3S,CNG,US,TRAN,HYD	1 ea
FL724-N	A22-74801-204	CLUSTER-ASSY,ICU3S-M2,HB,US,TRN,A	1 ea
FL724-A through Q	WAR260	COMPLETION STICKER	1 ea

Table 1

Removed Parts

U.S. and Canadian Dealers, please follow Warranty Failed Parts Tracking shipping instructions for the disposition of all removed parts. Export distributors, please destroy removed parts unless otherwise advised.

Labor Allowance

Table 2 - Labor Allowance

Campaign Number	Procedure	Time Allowed (hours)	SRT Code	Corrective Action
FL724-A through Q	Inspect instrument cluster	0.1	996-0990A	06-Inspect
FL724-A through Q	Inspect and replace ICU3S instrument cluster	0.3	996-0990B	12-Repair Recall/Campaign

Table 2

IMPORTANT: When the Recall has been completed, locate the base completion label in the appropriate location on the vehicle, and attach the red completion sticker provided in the recall kit (Form WAR260). If the vehicle does not have a base completion label, clean a spot on the appropriate location of the vehicle and first attach the base completion label (Form WAR259). If a recall kit is not required or there is no completion sticker in the kit, write the recall number on a blank sticker and attach it to the base completion label.

Claims for Credit

You will be reimbursed for your parts, labor, and handling (landed cost for Export Distributors) by submitting your claim through the Warranty system within 30 days of completing this campaign. Please reference the following information in OWL:

REVISIONS: The replacement part number for some groups in Table 1 below were incorrect. The table has been updated. Step 12 (applies to trucks only) has been expanded to emphasize that telltale carriers/cartridges stay on the same side as they are moved from the old to the new instrument cluster.

April 2017
FL724A-Q
NHTSA #16V-666 (Non-School Buses)
NHTSA #16V-664 (School Buses)
SECOND REVISED NOTICE

- Claim type is **Recall**.
- In the FTL Authorization field, enter the campaign number and appropriate condition code (e.g. **FL724-A, FL724-B, FL724-C, etc.**) .
- In the Primary Failed Part Number field, enter **25-FL724-000**.
- In the Parts field, enter the appropriate kit or part number(s) as shown in the Replacement Parts Table.
- In the Labor field, first enter the appropriate SRT from the Labor Allowance Table. Administrative time will be included automatically as SRT 939-0010A for 0.3 hours.
- The VMRS Component Code is **003-002-024** and the Cause Code is **A1 - Campaign**.
- **U.S. and Canada -- Reimbursement for Prior Repairs.** When a customer asks about reimbursement, please do the following:
 - Accept the documentation of the previous repair.
 - Make a brief check of the customer's paperwork to see if the repair may be eligible for reimbursement. (See the "Copy of Owner Letter" section of this bulletin for reimbursement guidelines.)
 - Submit an OWL Recall Pre-Approval Request for a decision.
 - Include the approved amount on your claim in the Other Charges section.
 - Attach the documentation to the pre-approval request.
 - If approved, submit a based on claim for the pre-approval.
 - Reimburse the customer the appropriate amount.

IMPORTANT: OWL must be viewed prior to performing the recall to ensure the vehicle is involved and the campaign has not been previously completed. Also, check for a completion sticker prior to beginning work.

U.S. and Canadian dealers, contact the Warranty Campaigns Department from 7:00 a.m. to 4:00 p.m. Pacific Time, Monday through Friday, via Web inquiry at DTNAConnect.com / WSC, or the Customer Assistance Center at (800) 385-4357, after normal business hours, if you have any questions or need additional information. Export distributors, submit a Web inquiry or contact your International Service Manager.

U.S. and Canadian Dealers: To return excess kit inventory related to this campaign, U.S. dealers must submit a Parts Authorization Return (PAR) to the Memphis PDC. Canadian dealers must submit a PAR to their facing PDC. All kits must be in resalable condition. PAR requests must include the original purchase invoice number. Export Distributors: Excess inventory is not returnable.

The letter notifying U.S. and Canadian vehicle owners is included for your reference.

Please note that the National Traffic and Motor Vehicle Safety Act, as amended (Title 49, United States Code, Chapter 301), requires the owner's vehicle(s) be corrected within a reasonable time after parts are available to you. The Act states that failure to repair a vehicle within 60 days after tender for repair shall be prima facie evidence of an unreasonable time. However, circumstances of a particular situation may reduce the 60 day period. Failure to repair a vehicle within a reasonable time can result in either the obligation to (a) replace the vehicle with an identical or reasonably equivalent vehicle, without charge, or (b) refund the purchase price in full, less a reasonable allowance for depreciation. The Act further prohibits dealers from selling a vehicle unless all outstanding recalls are performed. Any lessor is required to send a copy of the recall notification to the lessee within 10 days. Any subsequent stage manufacturer is required to forward this notice to its distributors and retail outlets within five working days.

April 2017
FL724A-Q
NHTSA #16V-666 (Non-School Buses)
NHTSA #16V-664 (School Buses)
SECOND REVISED NOTICE

Copy of Notice to Owners

Subject: ICU3S Instrument Cluster Hydraulic Brake Telltale

For the Notice to U.S. Customers: This notice is sent to you in accordance with the National Traffic and Motor Vehicle Safety Act. **For the Notice to Canadian Customers:** This notice is sent to you in accordance with the Canadian Motor Vehicle Safety Act.

Daimler Trucks North America LLC (DTNA), on behalf of its Freightliner Trucks Division and its wholly owned subsidiary, Freightliner Custom Chassis Corporation, has decided that a non-compliance with Federal Motor Vehicle Safety Standards (FMVSS) exists on specific Freightliner Business Class M2 vehicles and Freightliner Custom Chassis S2 bus and B2 (Thomas Built Buses C2 Saf-T-Liner) school bus chassis manufactured March 3, 2015, through September 8, 2016.

On certain hydraulic braked vehicles with ICU3s instrument clusters, the telltale for a brake malfunction says "PARK" instead of "BRAKE," as required by FMVSS 101 (Controls and Displays) and FMVSS 105 (Hydraulic and Electric Brake Systems). If "PARK" is illuminated instead of "BRAKE," the driver may not be aware there is a brake malfunction that could lead to a reduction or loss of braking, resulting in a possible vehicle crash.

The instrument clusters will be inspected and replaced with clusters displaying the correct warning as needed. **IMPORTANT:** Advance arrangements are required for buses, as the new instrument clusters are individually programmed for each vehicle. Advance arrangements are recommended for the trucks to be sure that the appropriate new instrument cluster is available when the customer arrives.

This is the second notice regarding this issue. The repair is now available. Please contact an authorized Daimler Trucks North America dealer to arrange to have the Recall performed and to ensure that parts are available at the dealership. To locate an authorized dealer, search online at www.Daimler-TrucksNorthAmerica.com / Contact Us / Find a Dealer. The Recall will take up to an hour and will be performed at no charge to you.

You may be liable for any progressive damage that results from your failure to complete the Recall within a reasonable time after receiving notification.

If you do not own the vehicle that corresponds to the identification number(s) which appears on the Recall Notification, please return the notification to the Warranty Campaigns Department with any information you can furnish that will assist us in locating the present owner. If you have leased this vehicle, Federal law requires that you forward this notice to the lessee within 10 days. If you are a subsequent stage manufacturer, Federal law requires that you forward this notice to your distributors and retail outlets within five working days. If you have paid to have this recall condition corrected prior to this notice, you may be eligible to receive reimbursement. Please see the reverse side of this notice for details.

For the Notice to U.S. Customers: If you have questions about this Recall, please contact the Warranty Campaigns Department at (800) 547-0712, 7:00 a.m. to 4:00 p.m. Pacific Time, Monday through Friday, e-mail address DTNA.Warranty.Campaigns@Daimler.com, or the Customer Assistance Center at (800) 385-4357 after normal business hours. If you are not able to have the defect remedied without charge and within a reasonable time, you may wish to submit a complaint to the Administrator, National Highway Traffic Safety Administration, 1200 New Jersey Avenue, SE., Washington, DC 20590; or call the Vehicle Safety Hotline at (888) 327-4236 (TTY: 800-424-9153); or to <http://www.safercar.gov>. **For the Notice to Canadian Customers:** If you have questions about this Recall, please contact the Warranty Campaigns Department at (800) 547-0712, 7:00 a.m. to 4:00 p.m. Pacific Time, Monday through Friday, e-mail address DTNA.Warranty.Campaigns@Daimler.com, or the Customer Assistance Center at (800) 385-4357 after normal business hours.

We regret any inconvenience this action may cause but feel certain you understand our interest in motor vehicle safety.

WARRANTY CAMPAIGNS DEPARTMENT

Enclosure

Page 4

April 2017
FL724A-Q
NHTSA #16V-666 (Non-School Buses)
NHTSA #16V-664 (School Buses)
SECOND REVISED NOTICE

**Reimbursement to Customers for Repairs
Performed Prior to Recall**

If you have already **paid** to have this recall condition corrected you may be eligible to receive reimbursement.

Requests for reimbursement may include parts and labor. Reimbursement may be limited to the amount the repair would have cost if completed by an authorized Daimler Trucks North America LLC dealer. The following documentation must be presented to your dealer for consideration for reimbursement.

Please provide original or clear copies of all receipts, invoices, and repair orders that show:

- The name and address of the person who paid for the repair
- The Vehicle Identification Number (VIN) of the vehicle that was repaired
- What problem occurred, what repair was done, when the repair was done
- Who repaired the vehicle
- The total cost of the repair expense that is being claimed
- Proof of payment for the repair (such as the front and back of a cancelled check or a credit card receipt)

Reimbursement will be made by check from your Daimler Trucks North America LLC dealer.

Please speak with your Daimler Trucks North America LLC authorized dealer concerning this matter.

April 2017
FL724A-Q
NHTSA #16V-666 (Non-School Buses)
NHTSA #16V-664 (School Buses)
SECOND REVISED NOTICE

Work Instructions

Subject: ICU3S Instrument Cluster Hydraulic Brake Telltale

Models Affected: Specific Freightliner Business Class M2 vehicles and Freightliner Custom Chassis S2 bus and B2 (Thomas Built Buses C2 Saf-T-Liner) school bus chassis manufactured March 3, 2015, through September 8, 2016.

REVISIONS: The replacement part number for some groups in Table 1 below were incorrect. The table has been updated. Step 12 (applies to trucks only) has been expanded to emphasize that telltale carriers/cartridges stay on the same side as they are moved from the old to the new instrument cluster.

NOTE: Order new instrument clusters for Freightliner Business Class M2 vehicles in groups FL724-A through FL724-H as noted in **Table 1** on page 2. The telltale cartridges will be moved from the existing cluster to the new ICU3s cluster. New instrument clusters for the Freightliner Custom Chassis bus chassis in groups FL724-I through FL724-Q will be completely pre-programmed and must be ordered by vehicle serial, part numbers are also in **Table 1**

ICU3S Instrument Cluster Inspection and Replacement

1. Check the base label (Form WAR259) for a completion sticker for FL724 (Form WAR260) indicating this work has been completed. The base label is usually located on the passenger-side door, about 12 inches (30 cm) below the door latch (trucks) or over the driver's window (buses). If a completion sticker is present, no work is needed. If a completion sticker is not present, proceed to the next step.
2. Park the vehicle, shut down the engine, and apply the parking brakes. Chock tires.
3. During the bulb check at key-on, inspect the telltales on the ICU3S (affected telltales will be illuminated for three seconds). See **Fig. 1** and **Fig. 2**

If the ICU3S has a "Park" telltale, continue with the next step.

If the ICU3S has a "Brake" telltale, no further work is needed. Clean a spot on the base label (Form WAR259), write the recall number, FL724, on a red completion sticker (Form WAR260), and attach it to the base label.

4. Attach a sticker to the driver side door frame (trucks) or the A-pillar next to the vehicle data sticker (buses) indicating the mileage from the driver display and the date that the ICU is being replaced.
5. Disconnect all negative leads from the batteries.



Air lines under pressure can whip dangerously if disconnected. Drain all air from the air tanks before disconnecting air lines. Disconnecting pressurized air lines can cause personal injury and/or property damage.

6. Discharge the air pressure from the primary and secondary air tanks.
7. Remove the dash trim piece by removing the eleven screws that secure it. All fasteners for this procedure are 10–16 Torx® capscrews. See **Fig. 3**.

April 2017
FL724A-Q
NHTSA #16V-666 (Non-School Buses)
NHTSA #16V-664 (School Buses)
SECOND REVISED NOTICE

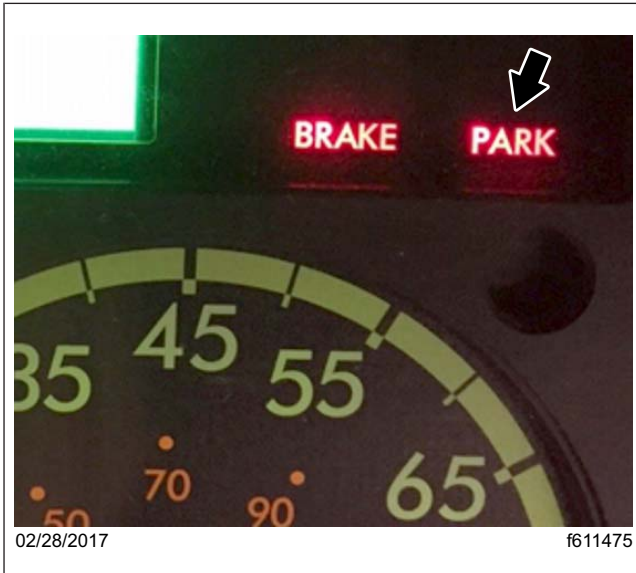

Fig. 1, "Park" Telltale - Replace ICU3S

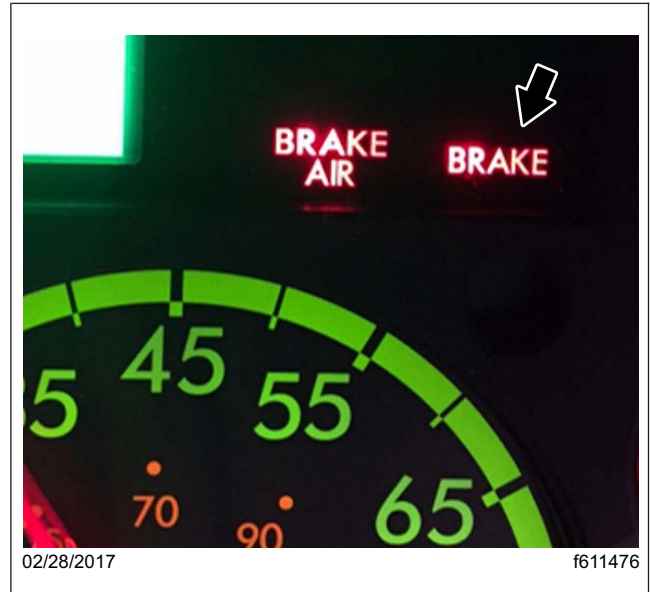

Fig. 2, "Brake" Telltale is OK - No Replacement

NOTICE

Do not forcibly pull the ICU3S from the dash. This may dislodge electrical connections or air lines from the back of the ICU3S, causing damage to connections, lines, or the dash.

8. Remove the four screws that secure the ICU.
9. Disconnect the two electrical connectors from the back of the ICU. See [Fig. 4](#).

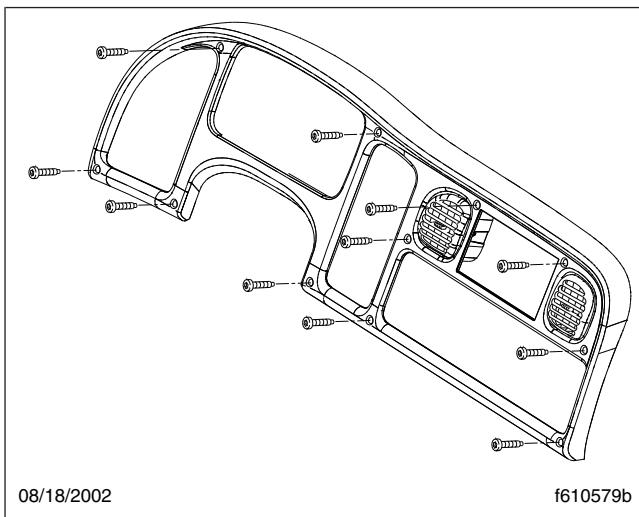

Fig. 3, Dash Trim Piece

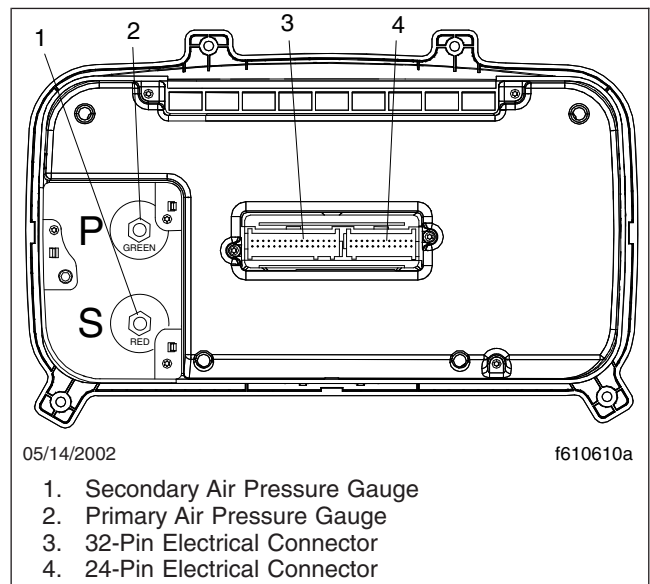

Fig. 4, ICU3, Rear View

April 2017

FL724A-Q

NHTSA #16V-666 (Non-School Buses)

NHTSA #16V-664 (School Buses)

SECOND REVISED NOTICE

10. Remove the air lines by pressing the push-lock connectors, then pulling the air lines away from the gauges. The lines are color-coded for ease of installation. The primary air line is green and is connected to the upper gauge. The secondary air line is red and is connected to the lower gauge.
 11. For M2 vehicles go to step 12, for buses go to step 13.
 12. Remove the two telltale carriers (cartridges) from the old ICU, making sure to pay attention to their orientation. Install the carriers on the new ICU, and make sure that the left and right carriers remain on the same sides as they were removed and that the arrow on the top is facing the same side as the display.
 13. Connect the air lines to the air gauges to the new ICU3S by pressing them firmly into the push-lock connector on the back of the gauge. The green air line connects to the primary (upper) gauge. The red air line connects to the secondary (lower) gauge.
 14. Connect the electrical connectors to the back of the ICU3S.
 15. Place the ICU3S in the dash opening and secure it with the four capscrews. Tighten the capscrews 30 lbf-in (340 N·cm).
 16. Install the dash trim piece and secure it with eleven capscrews. Tighten the capscrews 30 lbf-in (340 N·cm).
 17. Connect the batteries.
- NOTE: Mechanical (air) gauges do not make a sweep.
18. Turn on the ignition and test the operation of the cluster. All electronic gauges should make one complete sweep and return to their normal indicating positions. The warning and indicator lights should turn on, then off.
 19. Start the engine and verify proper operation of the air gauge module as the air pressure builds.
 20. Clean a spot on the base label (Form WAR259), write the recall number, FL724, on a red completion sticker (Form WAR260), and attach it to the base label.