



Service Bulletin

PRELIMINARY INFORMATION

Subject: Vibration Felt in Drive at Idle

Models: 2014-2018 Chevrolet Impala (VIN 1)

Attention: This PI also applies to any of the above models that may be Middle East or Israel Export from North America vehicles.

This PI has been revised to add the 2016-2018 Model Years. Please discard PI1420.

Condition/Concern

Some customers may comment that there is a vibration at idle while in Drive that can be felt through the steering wheel, driver's and passenger's seats or floor.

This condition may be caused by either or both the radiator upper mounts being misaligned or the powertrain mounts being unbalanced.

Recommendation/Instructions

Note: There are two different realignment procedures for the upper radiator mounts based on the engine RPO.

Follow the appropriate procedure below:

Engine RPO LFX and LFR

1. Inspect both upper radiator mounts for misalignment.

Note: Both upper radiator mounts are visible without removing any parts.



2. If the mounts are misaligned as illustrated above, skip the next step.

Note: If the mount is misaligned, the honeycomb of the mount will most likely be collapsed.

3. If the radiator mounts are aligned properly, perform the powertrain mount balance procedure. Refer to the Powertrain Mount Balancing in S After balancing the mounts, verify the concern has been corrected. If so the repair is complete. If vibration is still present, refer to Service

Information (SI) for further diagnoses.

4. Raise and support the vehicle. Refer to the Lifting and Jacking the Vehicle in SI.

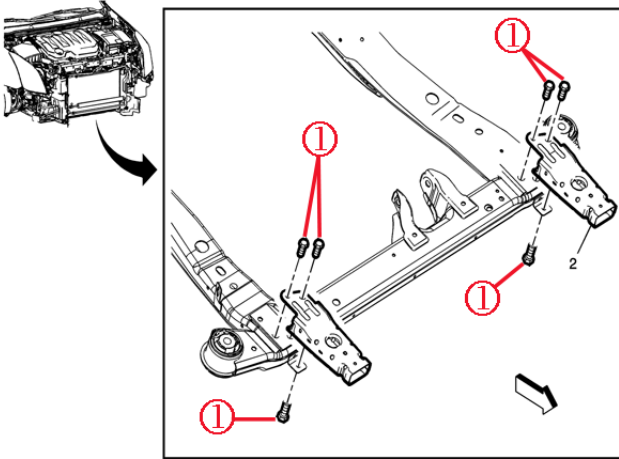

5. Loosen the radiator lower mount bolts (1).
 - To access the lower bolts, the front bumper fascia must be partially removed. Remove the lower push-in retainers and the four most inward wheelhouse liner screws.
6. Realign the upper radiator mounts.
7. If any damage to the mounts is noticed, replaced the damaged mount. Refer to the Radiator Upper Mount Replacement in SI.
8. Tighten the radiator lower mount bolts.

Tighten: Tighten the bolts to 22 Y (16 lb ft).

 - Re-intall any push-retainers and screws that where previously removed from the fascia.
9. Verify the concern is corrected. If so the repair is complete. If the vibration is still present, refer to Service Information (SI) for further diagnoses.

Engine RPO LKW and LUK

1. Inspect both upper radiator mounts for misalignment.

Note: Both upper radiator mounts are visible without removing any parts.



2. If the mounts are misaligned as illustrated above, skip the next step.

Note: If the mount is misaligned, the honeycomb of the mount will most likely be collapsed.
3. If the radiator mounts are aligned properly, perform the powertrain mount balance procedure. Refer to the Powertrain Mount Balancing in S. After balancing the mounts, verify the concern has been corrected. If vibration is still present, refer to Service Information (SI) for further diagnoses.

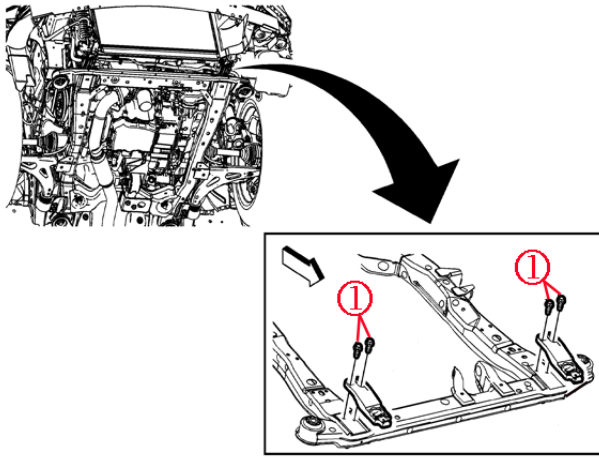

4. Loosen the radiator lower mount bolts (1).
5. Realign the upper radiator mounts.
6. If any damage of the mounts is noticed, replaced the mount. Refer to the Radiator Upper Mount Replacement in SI.
7. Tighten the radiator lower mount bolts.

Tighten: Tighten the bolts to 22 Y (16 lb ft).

8. Verify the concern is corrected. If so the repair is complete. If the vibration is still present, refer to Service Information (SI) for further diagnoses.

Parts Information

Part Number	Description	Qty
13306606	Insulator, Radiator Upper	1 or 2

Warranty Information

For vehicles repaired under the Powertrain coverage, use the following labor operation. Reference the Applicable Warranties section of Investigate Vehicle History (IVH) for coverage information.

Labor Operation	Description	Labor Time
4080868*	Inspect Radiator Upper Mounts	0.2 hr
Add	To Realignment of Radiator Upper Mounts	0.3 hr
Add	To Replace Radiator Upper Mounts (one or both)	1.3 hrs
Add	Balance Procedure – Powertrain Mounts	0.5 hr

*This is a unique Labor Operation for Bulletin use only.

GM bulletins are intended for use by professional technicians, NOT a "do-it-yourselfer". They are written to inform these technicians of conditions that may occur on some vehicles, or to provide information that could assist in the proper service of a vehicle. Properly trained technicians have the equipment, tools, safety instructions, and know-how to do a job properly and safely. If a condition is described, DO NOT assume that the bulletin applies to your vehicle, or that your vehicle will have that condition. See your GM dealer for information on whether your vehicle may benefit from this information.



WE SUPPORT VOLUNTARY TECHNICIAN CERTIFICATION