



# Service Bulletin

File in Section: -

Bulletin No.: 17-NA-227

Date: August, 2017

## INFORMATION

**Subject:** Tips to Prevent Unnecessary HV Battery Pack Replacement

Brand:	Model:	Model Year:		VIN:		Hybrid/ EV RPO	Transmission
		From:	To:	From:	To:		
Buick	LaCrosse (China Only) LaCrosse	2017	2017	All	All	HP4	—
		2018	2018	All	All	HP5	—
Chevrolet	Malibu Silverado	2016	2018	All	All	HP4	—
		2016	2018	All	All	HP5	—
GMC	Sierra	2016	2018	All	All	HP5	—

Involved Countries	North America, China and South Korea
--------------------	--------------------------------------

### Information

#### Bulletin Purpose

The General Motors Warranty Parts Center (WPC) has experienced some cases where the Hybrid/EV High Voltage (HV) Battery Pack has been unnecessarily replaced when a Service Technician was diagnosing a No Start Condition. This Condition may be accompanied by one or more DTCs. The following information may help to prevent misdiagnosis of an HV Battery Pack.

### Service Tips

#### Diagnostic Instructions

When starting to diagnose a vehicle, **always perform the following actions first:**

- Perform the Diagnostic System Check. This procedure **must** be performed prior to performing other diagnostic procedures, as this prevents misdiagnosis where there are integrated system dependencies. Refer to Diagnostic System Check - Vehicle in SI
- Review the content of Strategy Based Diagnosis. It provides an overview on how a technician should properly diagnose a vehicle. Refer to Strategy Based Diagnosis in SI.
- Review the content of Diagnostic Procedure Instructions. It is an instructional overview of all categories which may be included in a diagnostic procedure. Refer to Diagnostic Procedure Instructions in SI.

## Diagnostic Trouble Codes

**Notice:** Any diagnostic step that asks if a DTC is “set” refers to a Set, Current, Present or Active DTC status. This does not include any other DTC status. For example History, Not Run, Passed and Failed.

Depending on the model year, the vehicle and the Hybrid/EV System, one or more of the following DTCs may be set when encountering a vehicle with a No Start Condition: P1E00, P0AFA, P1E0C, P0AA9 or P0ABC (this list is not all inclusive).

- For example, DTC P0AFA is a type A DTC. When this DTC is Set, Current, Present or Active the following occurs:

**Action Taken When the DTC Sets** Once the vehicle has been turned OFF, the contactors will be prevented from closing until the fault is cleared.

- The vehicle will not start until the Condition is corrected and the following is performed:

**Conditions for Clearing the DTC** The Clear Secured High Voltage DTCs reset function must be performed with a scan tool before clear codes.

## Clear Secured High Voltage DTCs

The hybrid powertrain control modules 1 and 2 independently monitor for high voltage safety conditions such as airbag deploy events and certain high voltage system faults. When either module identifies one of these conditions, a DTC may set and the vehicle is placed into a ‘high voltage lockout’ state. While in the lockout state, the high voltage contactor relays are prevented from closing. The purpose of the high voltage lockout state is to allow for High Voltage System Inspection prior to re-enabling. A complete inspection of the high voltage system and components must be performed if the vehicle has been involved in a collision. Perform the High Voltage System Inspection procedure, if necessary, prior to clearing a Secured High Voltage DTCs/lockout state.

## HV Lockout State Without a Corresponding DTC

- The following conditions may result in a HV lockout state without a corresponding DTC:
  - High voltage component replacement.
  - Low 12 V battery event.
  - SPS programming event.
  - Airbag deployment/crash event detected: The Inflatable Restraint Sensing and Diagnostic Module may or may not set a DTC but will continue to broadcast a crash event status until reset.
- Performing a scan tool DTC Clear may clear the diagnostic that set the HV lockout state, but will not reset the lockout.
- Clearing powertrain DTCs will set the Inspection/Maintenance (I/M) system status indicators to NO.
- The Clear Secured High Voltage DTCs procedure must be completed when the following components, as applicable, are replaced:
  - K16 Hybrid/EV Battery Energy Control Module
  - K112A – K112H Hybrid/EV Battery Interface Control Module
  - A4 Hybrid/EV Battery Pack

- K114A Hybrid/EV Powertrain Control Module 1
- K114B Hybrid/EV Powertrain Control Module 2

## Contactors Open Reasons Reset

The hybrid/EV powertrain control module 2, Hybrid/EV Battery Contactor Open Reasons scan tool parameter list identifies all past events that commanded contactors open. The parameters can only be reset by either reprogramming the hybrid/EV powertrain control module 2 or by performing the scan tool Hybrid/EV Battery Contactor Open Reasons Reset function. To aid in possible future intermittent diagnosis, the parameters should be reset to NO once all diagnostic procedures are successfully completed.

## Drive Motor Battery High Voltage Manual Disconnect Lever — Purpose and Inspection

### High Voltage Manual Disconnect Lever — Purpose

Hybrid/EV vehicles are equipped with a High Voltage Manual Disconnect Lever also known as a Manual Service Disconnect (MSD). The MSD is a shut-off switch to the high voltage battery designed to **manually shut off** high voltage power **before** servicing the vehicle. If an MSD is not installed properly, **whether from the factory or when the vehicle is being serviced**, it could become loose and may disconnect while the vehicle is being driven, which would then cut off all high-voltage power to the vehicle. The loss of high-voltage power to these vehicles would cut propulsion energy and effectively stall the vehicle, which could affect the driver’s ability to control the vehicle and could increase the risk of a crash.

### High Voltage Manual Disconnect Lever — Inspection

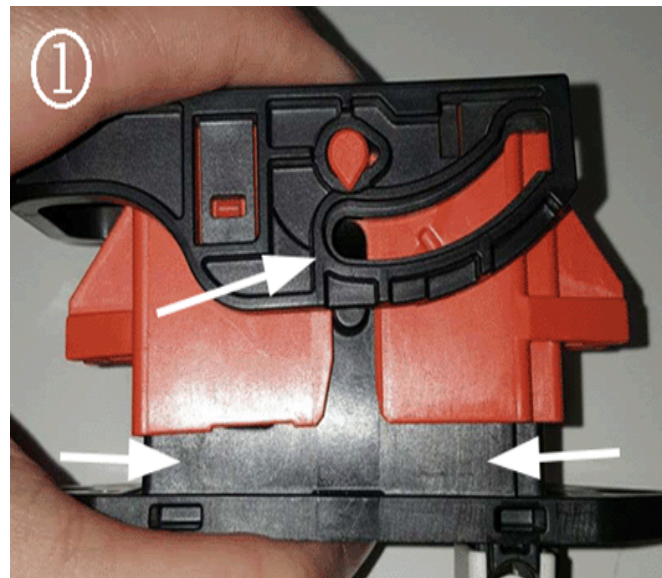

4829192

Shown is an example of an **improperly installed** Drive Motor Battery High Voltage Manual Disconnect Lever (1).

Gain access to the Drive Motor Battery High Voltage Manual Disconnect Lever (1) and inspect it to ensure that it is properly seated and retained. Refer to Drive Motor Battery High Voltage Manual Disconnect Lever in SI.

⇒ If the Drive Motor Battery High Voltage Manual Disconnect Lever is not properly seated and retained, refer to Drive Motor Battery High Voltage Manual Disconnect Lever — Installation Procedure in this Bulletin.

## Drive Motor Battery High Voltage Manual Disconnect Lever — Installation Procedure

Use this procedure to properly install the Drive Motor Battery High Voltage Manual Disconnect Lever.

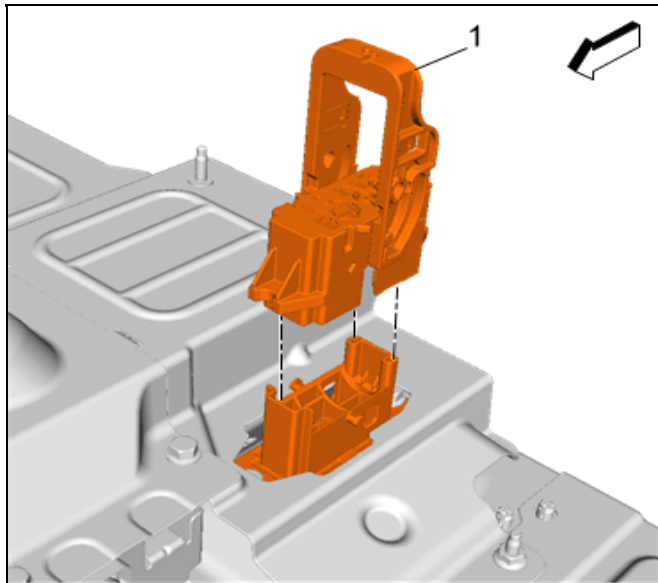

4290941

1. Install the Drive Motor Battery High Voltage Manual Disconnect Lever (1).

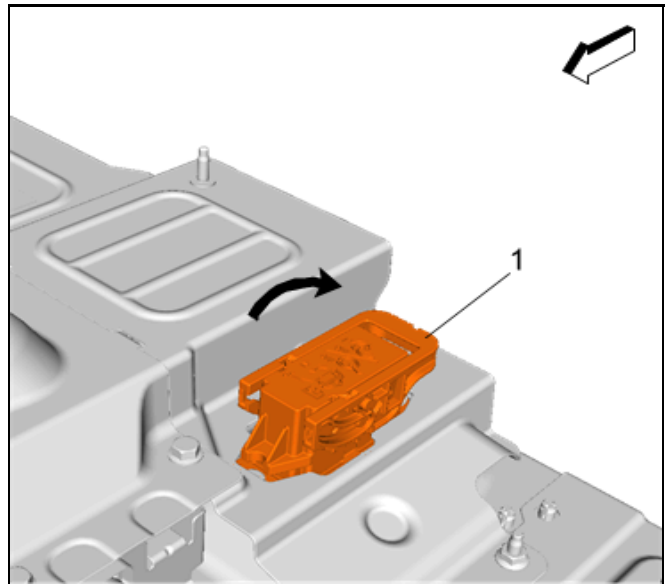

4290945

**Notice:** It is imperative that the MSD is fully inserted into the base and the locking pins are engaged BEFORE rotating the cam lever down. When properly installed, the MSD should be flush with the base and the locking pins will be inside the retaining lever ramps.

2. Rotate downwards the Drive Motor Battery High Voltage Manual Disconnect Lever Handle (1).

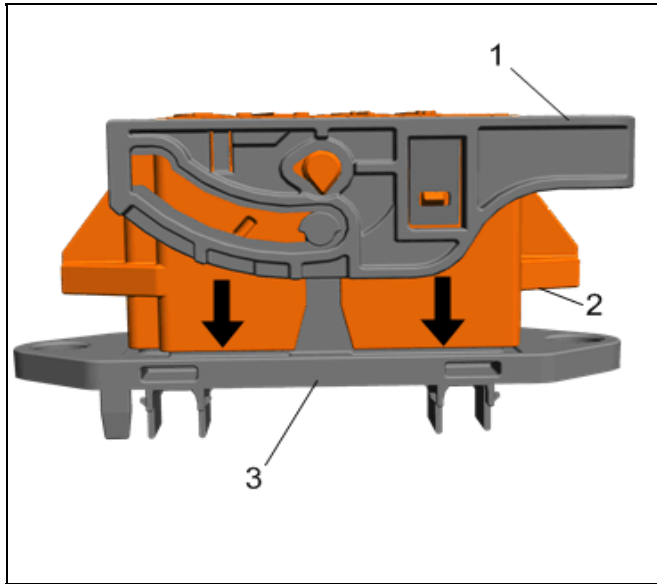

4541459

**Notice:** Ensure that the drive motor battery high voltage manual disconnect lever (MSD) is fully inserted into the base (flush with its mating surface) and the locking pins are inside the retaining lever ramps. Failure to properly insert and lock the MSD may cause the MSD to disconnect, resulting in loss of vehicle propulsion without warning.

3. When rotating the Drive Motor Battery High Voltage Manual Disconnect lever (1) into the locked position, make sure the Drive Motor Battery High Voltage Manual Disconnect Lever (2) is flush with the connector base (3).

### Warranty Information

For vehicles repaired under the U.S. Bumper-to-Bumper Warranty Coverage (Canadian Base Warranty Coverage) use the following Labor Operation. Reference the Applicable Warranties section of Investigate Vehicle History (IVH) for coverage information.

Labor Operation	Description	Labor Time
5480488*	Ensure Drive Motor Battery High Voltage Manual Disconnect Lever is Fully Connected	0.2 hr
*This is a unique Labor Operation for Bulletin use only.		

### Version Information

Version	2
Modified	August 11, 2017 – Added a Warranty Information section.

