



Service Bulletin

File in Section: -

Bulletin No.: 16-NA-061

Date: December, 2017

TECHNICAL

Subject: Service Tire Monitor System/ Tire Pressures Display Dashes/ RKE Short Range/ No Fob Detected Message

Attention: This Bulletin also applies to any of the models that may be Export from North America vehicles.

Brand:	Model:	Model Year:		VIN:		Engine:	Transmission:
		from	to	from	to		
Cadillac	ATS, CTS, XTS	2014	2018				
Cadillac	Escalade Models	2015	2018				
Chevrolet	Suburban, Tahoe	2015	2018				
GMC	Yukon Models	2015	2018				

Condition	<p>Some customers may comment on any of the following issues:</p> <ul style="list-style-type: none"> • One or more tire pressures display dashes • Service Tire Monitor System Message • Key fob poor range or inoperative (lock, unlock, remote start, etc.) • "No Fob Detected" message or Passive entry system inoperative (if equipped)
------------------	---

Cause	<p>The technician may find any of the following DTCs set in the BCM associated with the vehicle tire pressure sensors: C0750, C0755, C0760 and/or C0765.</p> <p>These concerns could be caused by a poor OR disconnected antenna connection for the Remote Control Door Lock Receiver (RCDLR). The RCDLR antenna system consists of the following four components:</p>
--------------	--

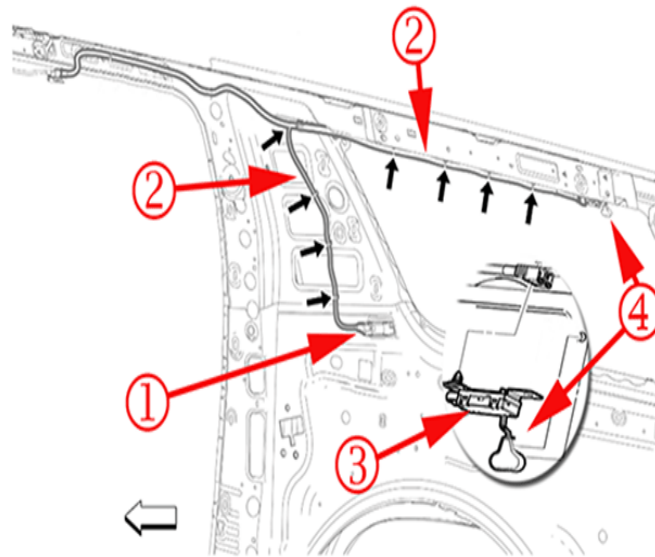

4233435

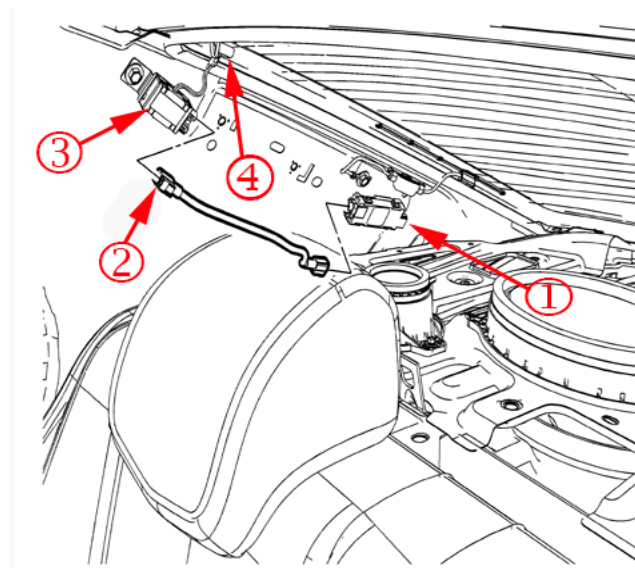

4421592

1. RCDLR
2. Coax cable
3. Antenna Amplifier Module
4. Antenna (located in right rear glass)

Correction

Before any components are replaced for the conditions listed above, please review the following information and reconnect any disconnects and re-evaluate the vehicle.

There are 3 locations that the RCDLR antenna system can become disconnected:

1. Antenna Amplifier Module (3) disconnected from antenna at the right rear glass (4)
2. Coax cable (2) disconnected at the Antenna Amplifier Module (3)
3. Coax cable (2) disconnected at the RCDLR (1)

The closer the disconnect is to the RCDLR, the greater number of symptoms will be noticed.

Examples:

1. Antenna Amplifier Module disconnected from the Antenna at right rear glass (4) - There may be little to no noticeable issues, may receive a complaint the RKE range is a little shorter than a like vehicle.
2. Coax cable disconnected at the Antenna Amplifier Module - The RCDLR may have intermittent issues receiving signals from the TPM sensors that are farthest from the RCDLR (LF, LR, RF tires). The DIC may display Service Tire Monitor System message and dashes for these tire pressures. In most cases, the signal from the right rear tire sensor, which is the closest to the RCDLR, will not have any issues. The RKE will have a shorter range.
3. Coax Cable disconnected at the RCDLR - The RCDLR may not receive any TPM sensor signals. The Service Tire Monitor System message and the tire pressures will show dashes in the DIC. The RKE may work when the fob is inside the vehicle or immediately outside the vehicle. May have Passive entry/start issues like No Fob Detected message or Passive entry inoperative. If the fob is put into the fob pocket the vehicle will start.

After any repair, perform a Tire Pressure Learn.

Warranty Information

For wiring repairs covered under warranty, please refer to latest version of Bulletin 10-00-89-005 for warranty information on wire/connector repairs.

Version	2
Modified	December 19, 2017 – Added the 2017-2018 Model Years.

