



# Service Bulletin

File in Section: -

Bulletin No.: 17-NA-367

Date: November, 2017

## TECHNICAL

**Subject: High Efforts Required to Press Steering Wheel Pad to Sound Horn**

Brand:	Model:	Model Year:		VIN:		Engine:	Transmission:
		from	to	from	to		
GMC	Acadia Denali (VIN N)	2017	2017			All	All

<b>Involved Region or Country</b>	North America and Middle East
<b>Additional Options (RPOs)</b>	Equipped with STEERING WHEEL-DELUXE (N30) and STEERING WHEEL HEAT-MANUAL (UVD)
<b>Condition</b>	Some customers may comment on the high effort required to sound the horn.
<b>Cause</b>	The cause of the condition may be that the wiring branches in the original heated steering wheel harness may produce enough interference to cause higher efforts necessary to sound the horn.
<b>Correction</b>	Replace the original 2 pin steering wheel horn switch wiring harness with the new design 3 pin harness listed in the Parts table, following the Service Procedure below.

## Service Procedure

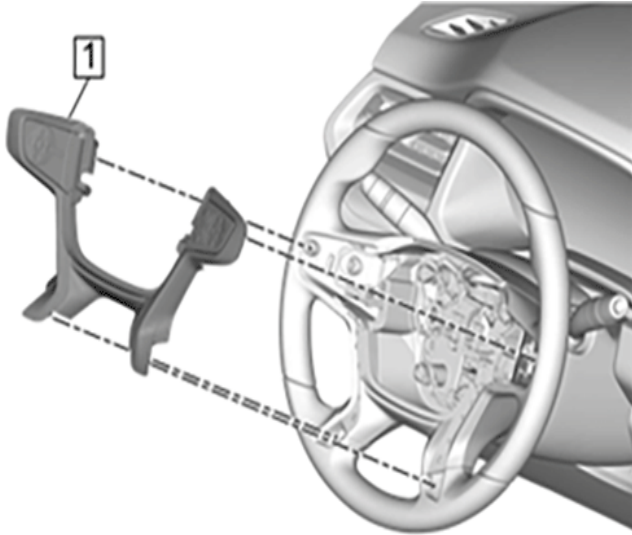

4868200

1. Remove the steering wheel airbag and steering wheel spoke cover (1). Refer to *Steering Wheel Spoke Cover Replacement* in SI.

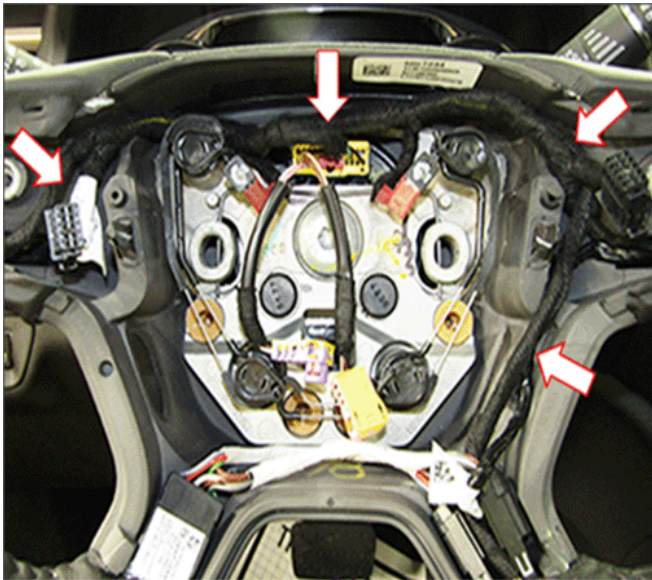

4868201

2. Before removing, note the routing and connector locations of the original steering wheel horn switch harness.

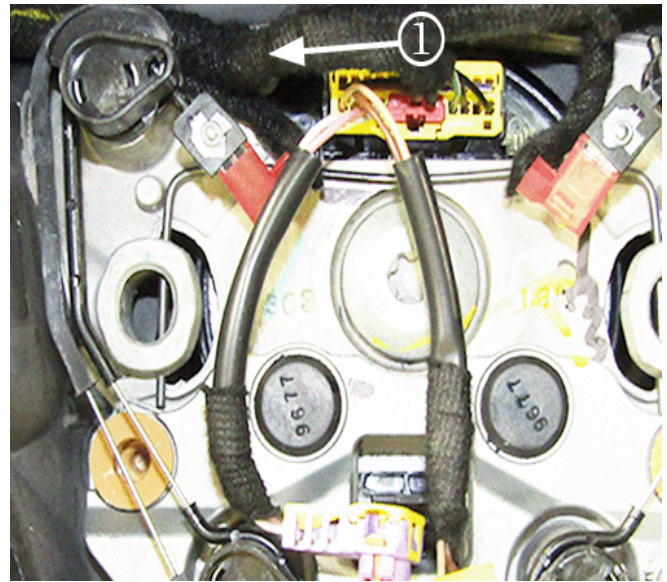

4868203

3. Disconnect the connectors, cut the single tie strap (1) near the left, red connector and remove the original harness from the steering wheel.



4868204

4. Position the new replacement harness to the

steering wheel:

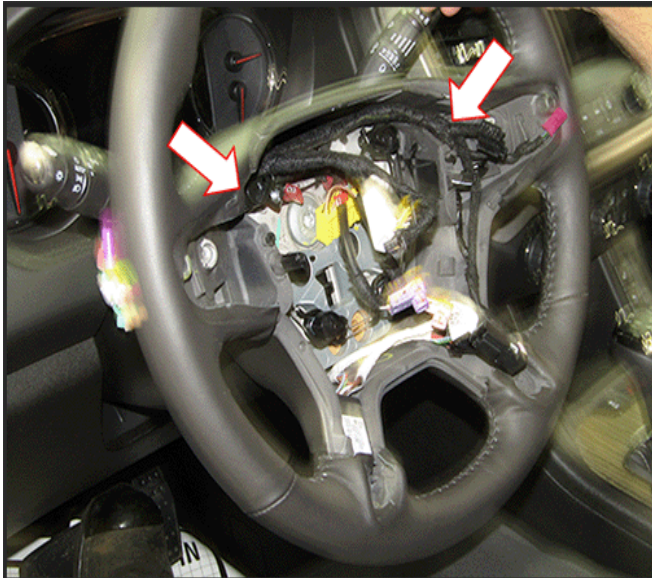

4868205

- 4.1. Route the harness across the top of the steering wheel, tucking the harness downward around the upper corners.

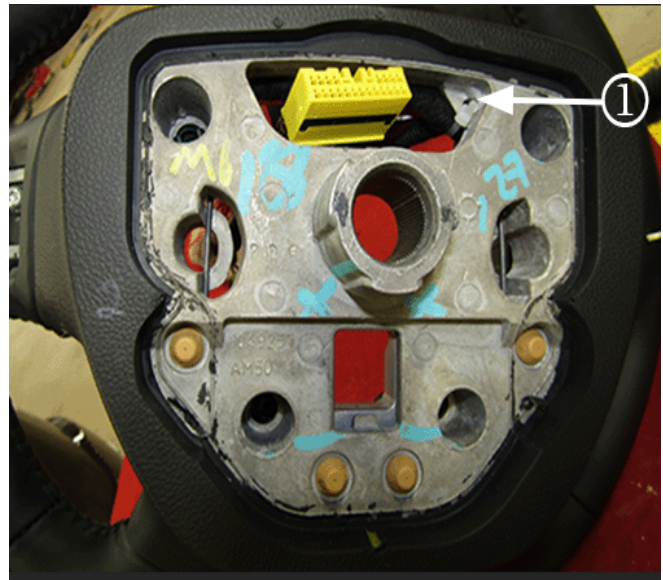

4868211

**Tip:** For illustration purposes only, the graphic above shows the location of the tie strap hole (1), from the backside of the steering wheel.

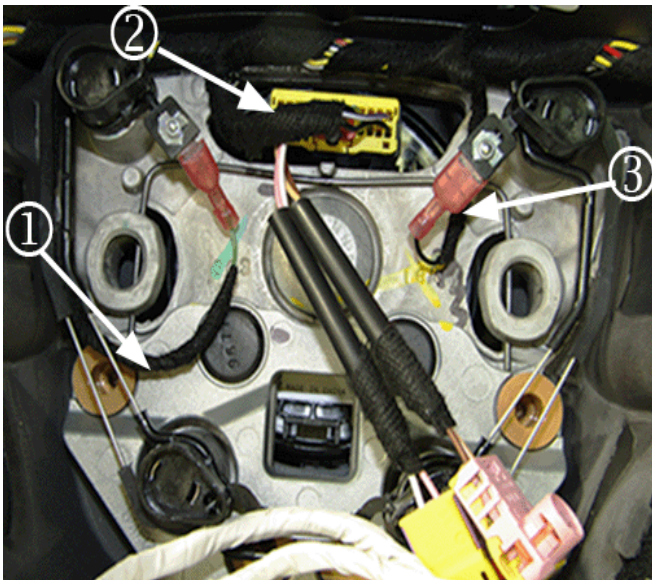

4868207

- 4.2. Route the left leg (1) of the red connector under the spring mechanism and back up to the connector.
- 4.3. Connect the larger yellow connector (2) and the right leg of the harness (3) to the red connector.

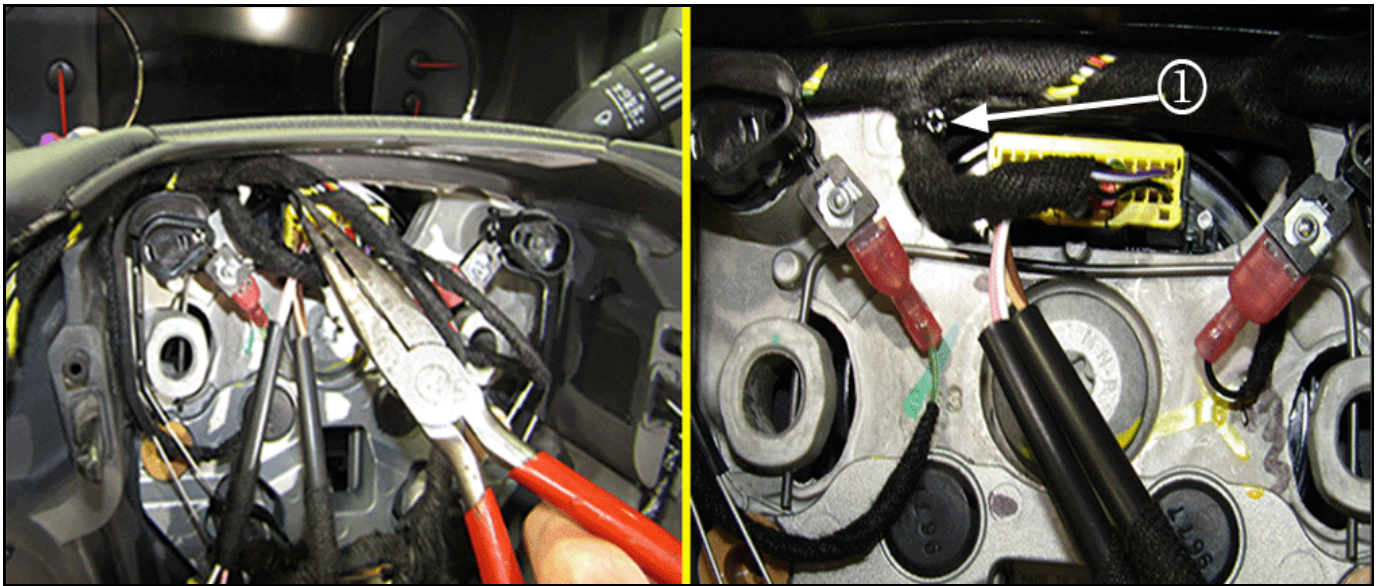

4868213

4.4. To help secure the harness across the top, install a tie strap (1) to the downward leg running to the yellow connector. This will help minimize interference of the harness bundle running along the top of the steering wheel.

**Tip:**

Leave a slight amount of slack in the right side radio control switch to enable plugging the connector to the switch, after installation of the wheel spoke cover fastener.

4.5. Complete the harness routing and wiring connectors down both sides of the steering wheel.

**Parts Information**

Causal Part	Description	Part Number	Qty
X	HARNESS ASM-STRG WHL HORN SW WRG	84360985	1

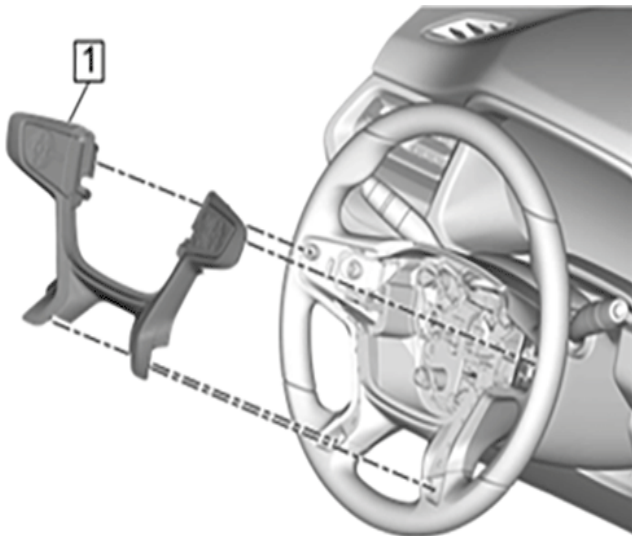

4868200

5. Reinstall the steering wheel spoke cover (1) and airbag. Refer to *Steering Wheel Spoke Cover Replacement* in SI.
6. Verify improved efforts for sounding horn.

## Warranty Information

For vehicles repaired under the Bumper-to-Bumper coverage (Canada Base Warranty coverage), use the following labor operation. Reference the Applicable Warranties section of Investigate Vehicle History (IVH) for coverage information.

Labor Operation	Description	Labor Time
2080928*	New Design Steering Wheel Horn Switch Wiring Harness Replacement	0.6 hr
*This is a unique Labor Operation for Bulletin use only.		

Version	1
Modified	Released November 20, 2017

