



# Service Bulletin

File in Section: -

Bulletin No.: 17-NA-258

Date: December, 2017

## TECHNICAL

**Subject:** Excessive Wind Noise from Front Side Door Glass Area

This Bulletin replaces PI1221. Please discard PI1221.

Brand:	Model:	Model Year:		VIN:		Engine:	Transmission:
		from	to	from	to		
Chevrolet GMC	Silverado 1500 Sierra 1500	2014	2014			All	All
Chevrolet GMC	Silverado Sierra	2015	2018				

<b>Involved Region or Country</b>	North America and N.A. Export Regions
<b>Condition</b>	Some customers may comment on hearing excessive wind noise coming from the front side door glass area.
<b>Cause</b>	The cause of the condition may be any of the following three primary factors:



3806381

- Improper front side door fit to roof.

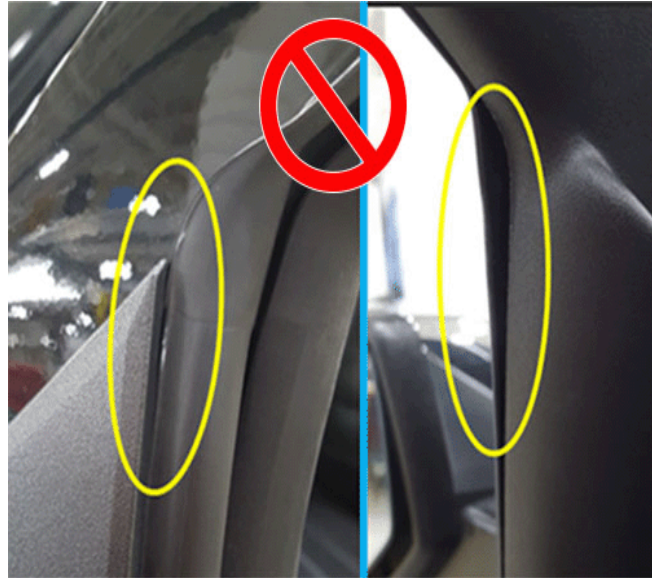

4846275

	 <p style="text-align: right;">4846276</p> <ul style="list-style-type: none"> <li>• Incorrectly installed front side door window weatherstrip.</li> <li>• Wind noise generated from sheet metal openings in the upper door frame.</li> </ul>
<p><b>Correction</b></p>	<p><b>Note:</b> In cases where the noise can't be verified coming from the door, and may be coming from the rear cab area, see Bulletin #17-NA-151.</p> <p>Verify the condition and repair following the steps outlined in the Service Procedure below.</p>

**Service Procedure**



**Note:** These vehicle models use an inlay door construction, with the door fitting sub-flush to the body header by 1-2 mm (0.040–0.080 in).

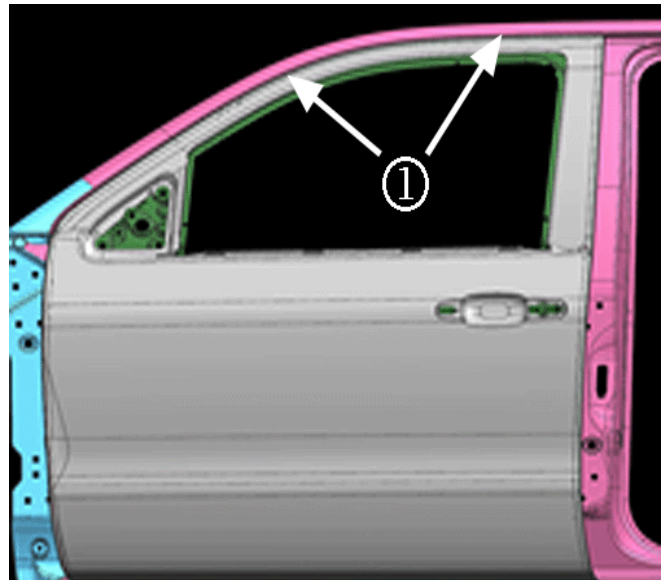

1. At the two locations (1) shown in the illustration above, inspect the front door fit as to meeting the suggested 1-2 mm (0.40–0.80 in) sub-flush dimension.
  - If the door fit meets the sub-flush specification, no door adjustment is necessary and you can jump ahead to step #4.
  - If the door fit DOES NOT meet the sub-flush specification, continue to step #2 to start the door adjustment.

**Important:** The door header bending procedure is only suggested for technicians experienced in finessing sheet metal fits.

2. In conditions where the door header is outboard the design intent, a 1-2 mm (0.040–0.080 in) change may be accomplished by bending the door header inboard.

- 2.1. Lower the front side door glass.
- 2.2. Placing one hand at the belt and the other at the door header, carefully attempt to bend the door about the belt.
- 2.3. Recheck the door fit to the body header.

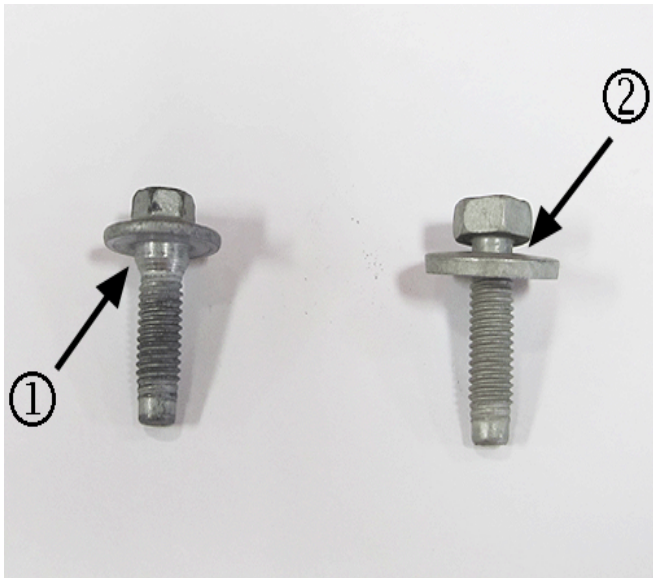

3806388

**Note:** The referenced hinge service bolt (2) is non-shouldered and will allow more adjustment than the original shouldered bolt (1).

3. If bending the door header does not resolve the condition, the door fit must be adjusted by adding two hinge service bolts, P/N 11561763.

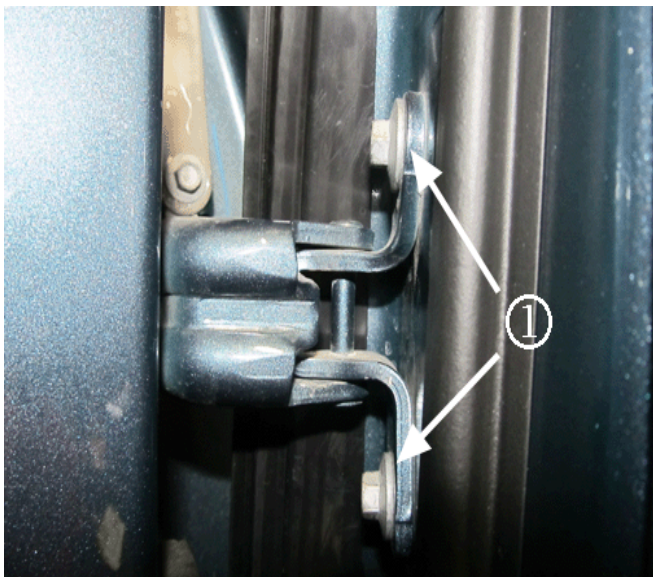

3806391

**Important:** Do NOT touch the body side hinge bolts or the door side lower hinge, lower bolt.

- 3.1. Remove both **door side** upper hinge bolts (1).



3806392

- 3.2. On the lower hinge, loosen the **door side** upper bolt (1).
- 3.3. Replace both door side upper hinge bolts with service bolt P/N 11561763.
- 3.4. Tighten the new bolts while applying inboard pressure to the door.

#### **Tighten**

Tighten the bolts to 25 N•m (18 lb ft).

- 3.5. Verify the door fit and tighten the remaining bolt. Verify proper torque on all four door side hinge bolts.

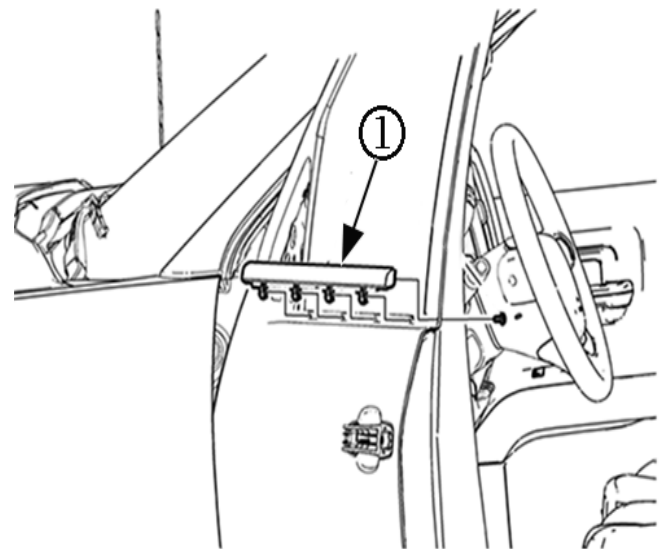

4846278

4. Remove the front door trim panel, garnish molding, outside rearview mirror and belt reveal molding. Refer to *Front Side Door Window Belt Reveal Molding Replacement* in SI.

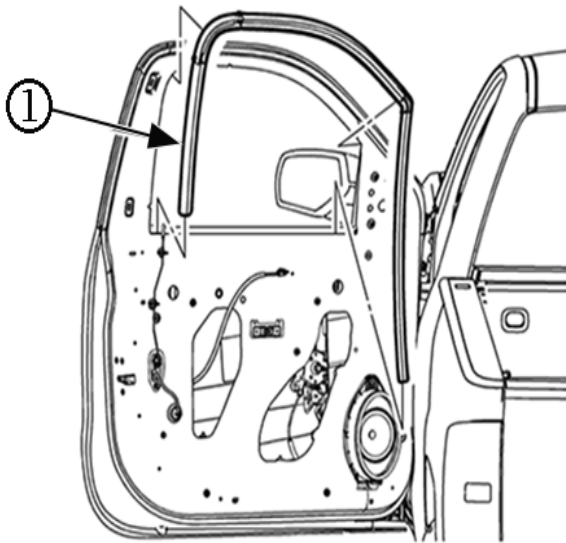

4846279

5. Remove the front window inner sealing strip, front window, and the front window weatherstrip. Refer to *Front Side Door Window Weatherstrip Replacement* in SI.

Deadener # P10630, or an equivalent from the Parts Table below, into the metal glass run channel of the upper door frame by following the steps below:

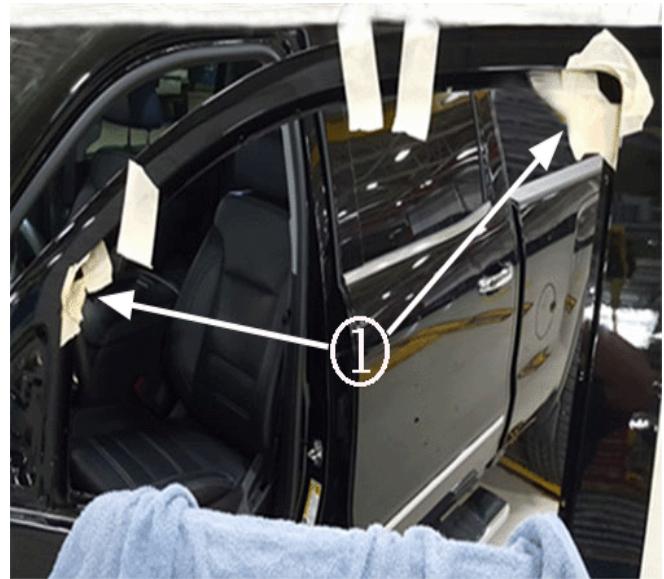

4846283

6.1. To help contain where the foam sealer will be injected, tape off two areas (1) around the top of the metal door glass run channel openings. One near the top of the mirror shark fin, and the other at the top of the B-pillar.



4846281

6. Inject Kent® Ure-Foam Expandible Foam Sound



4846284

6.2. Inject the foam sealer into both metal glass run channel openings and quickly tape glass over the injected holes to help contain the sealer.  
 6.3. Wait approximately 10 minutes to allow the foam to dry then remove all of the tape.

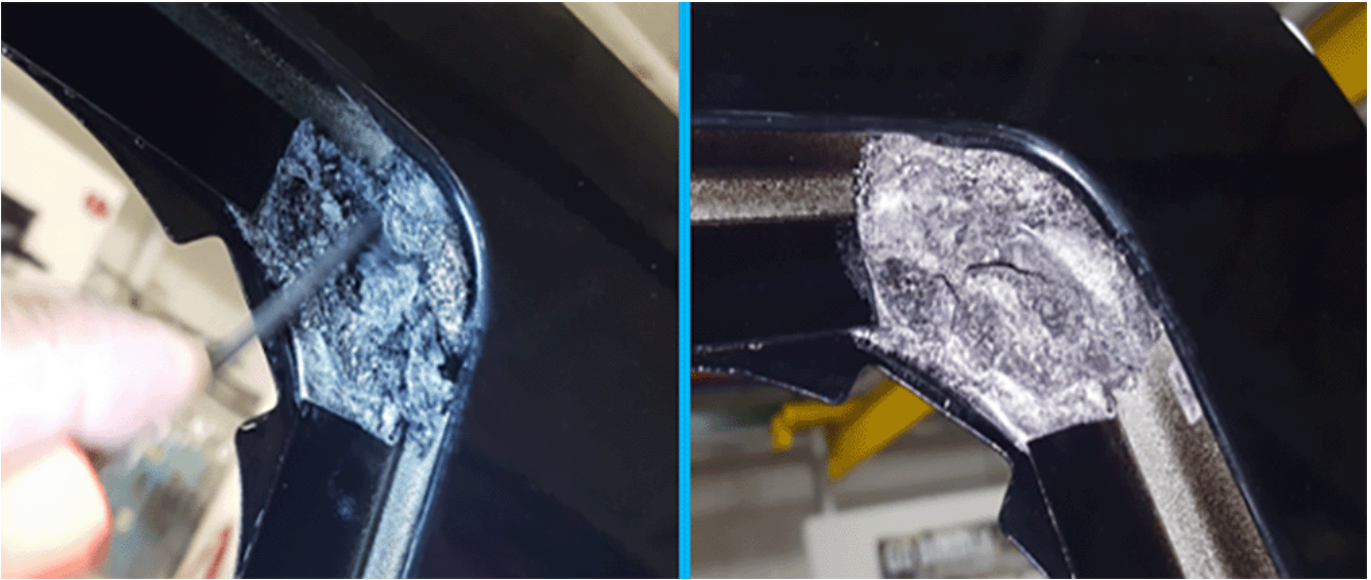

4846285

- 6.4. Scrape/cut out all excess foam to enable the rubber glass run channel to be reinstalled with no interferences.

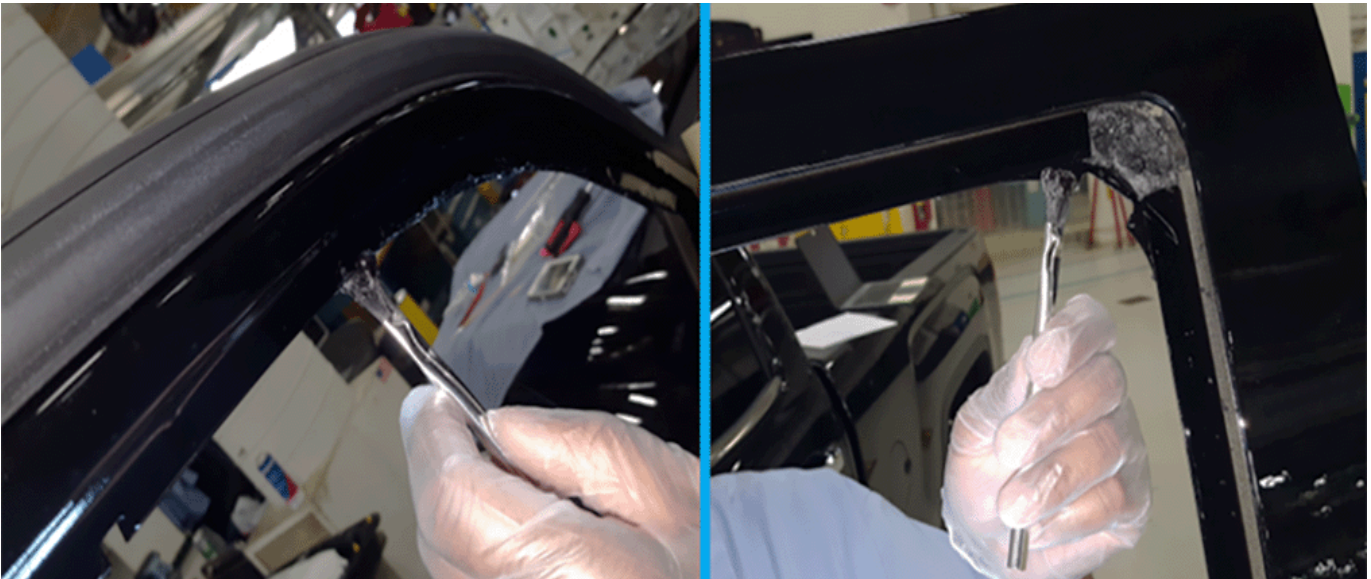

4846287

- 6.5. Using Kent® High Tech Clear Seam Sealer P 10200, or an equivalent from the Parts Table below, add/brush seam sealer to the door pinch weld flange to totally seal the door outer and inner sheet metal at the top of the door header.



4846288

- 6.6. Let the seam sealer dry for approximately 10 minutes, then clean with \*3M Adhesive Remover, or equivalent, to remove any excess residue.

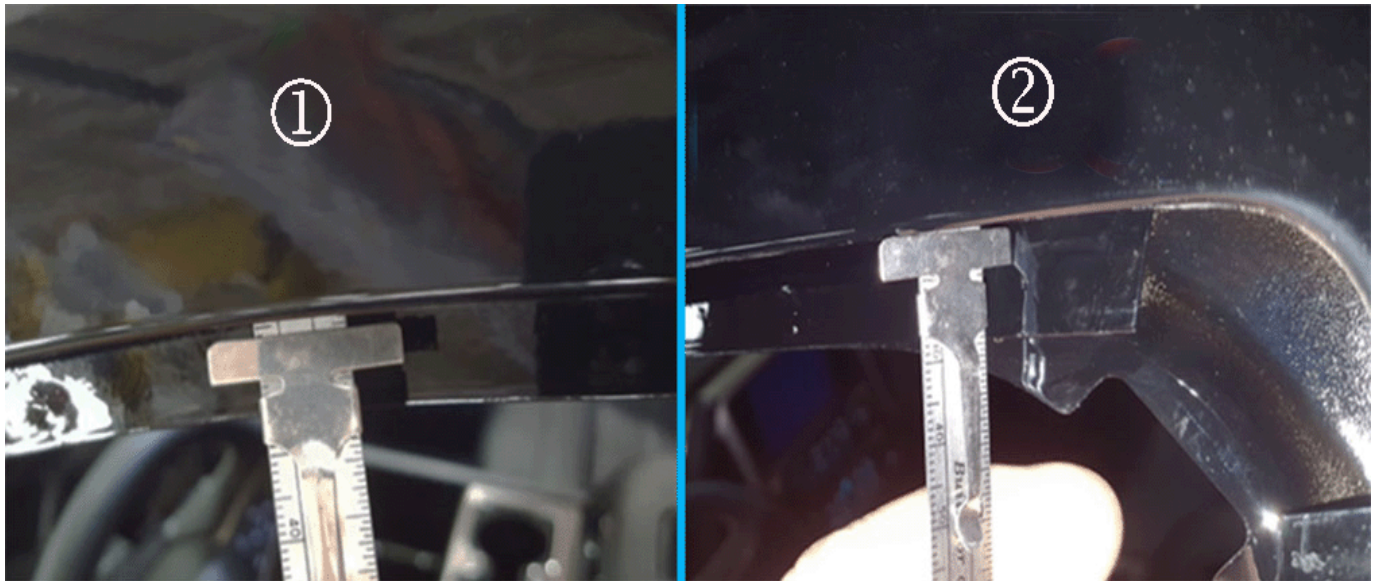

4846289

- 6.7. Inspect the upper door frame metal glass run channel, just forward of the B pillar, for possibly being out of design location.
- If the metal run channel is approximately the same depth across the top (1), no additional repair in this area is needed, and you can move ahead to step # 8.
  - If the metal run channel is approximately 1.5 mm higher (up/down) (2), continue to step # 7 to add foam tape.

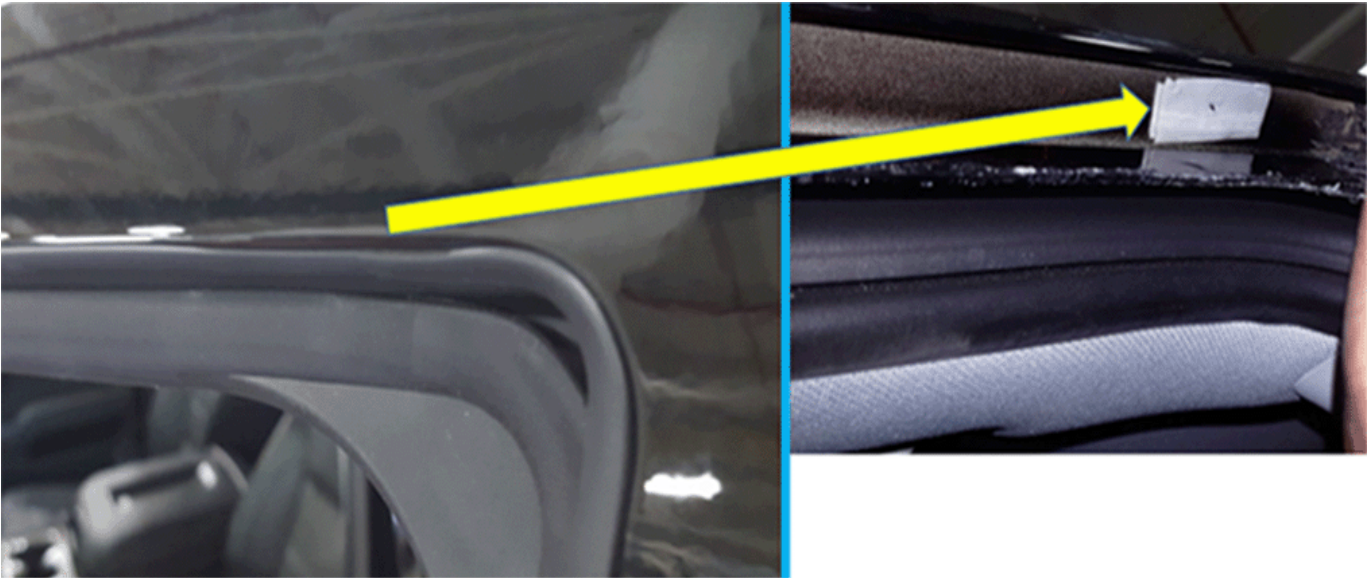

4846290

- 7. Obtained locally, add a 2 mm thick foam shim to prevent the rubber glass run channel from getting installed too deep. The approximate location is shown in the graphic above.

**Note: The graphics below are “before and after” examples which help show the proper positioning of the front door window weatherstrip.**



4846291



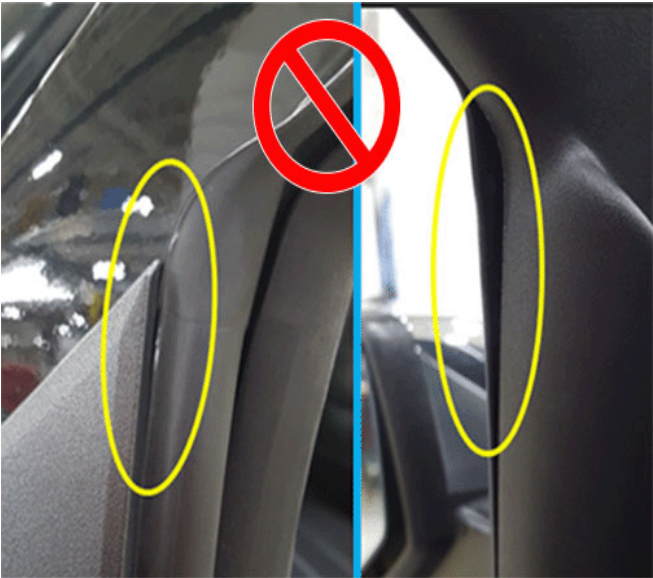

4846293



4846294

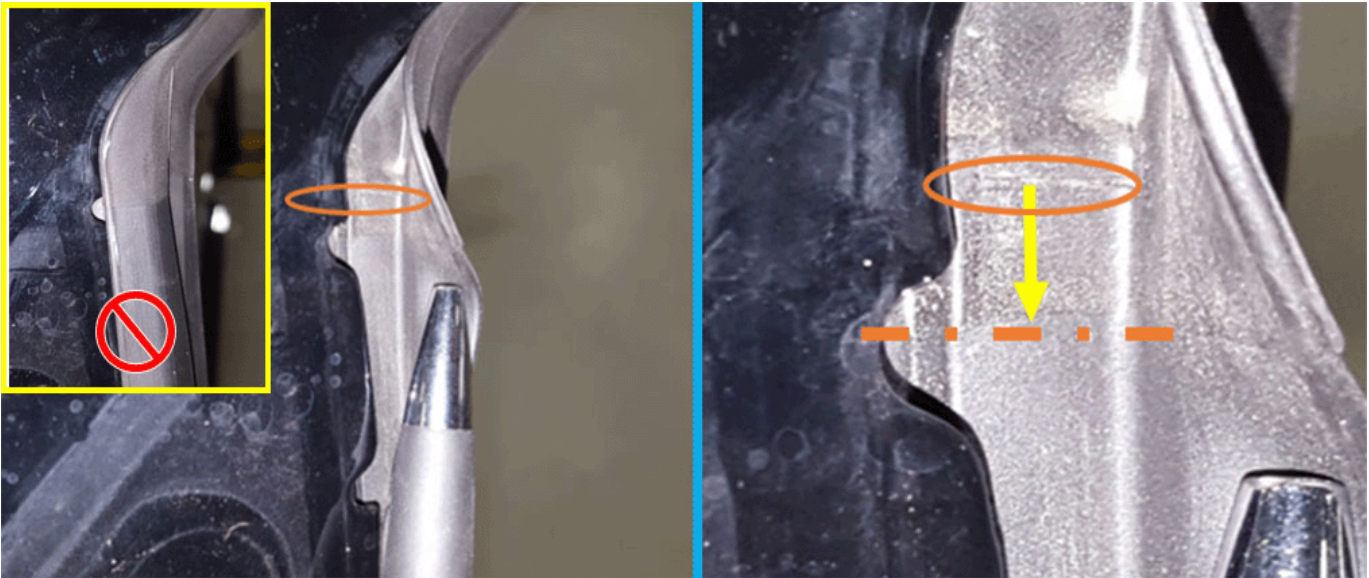

4846295

**Important:** The last example above shows the front, upper corner of the weatherstrip installed too high and well out of position. The feature line (shown circled) should be located down at the center-line of the metal notch.



4846296

**Note:** Applying GM Glass Cleaner, P/N 19287404 (Canada P/N 8865156), or even plain water, to the weatherstrip will allow the part to slide and be re-positioned more easily during installation.

8. Reinstall the front window inner sealing strip, front window, and the front window weatherstrip. Refer to *Front Side Door Window Weatherstrip Replacement* in SI. AND ALSO utilize the additional detailed steps below.
  - 8.1. Position the weatherstrip to the door frame and insert the front A-pillar leg down into the window opening of the sheet metal.

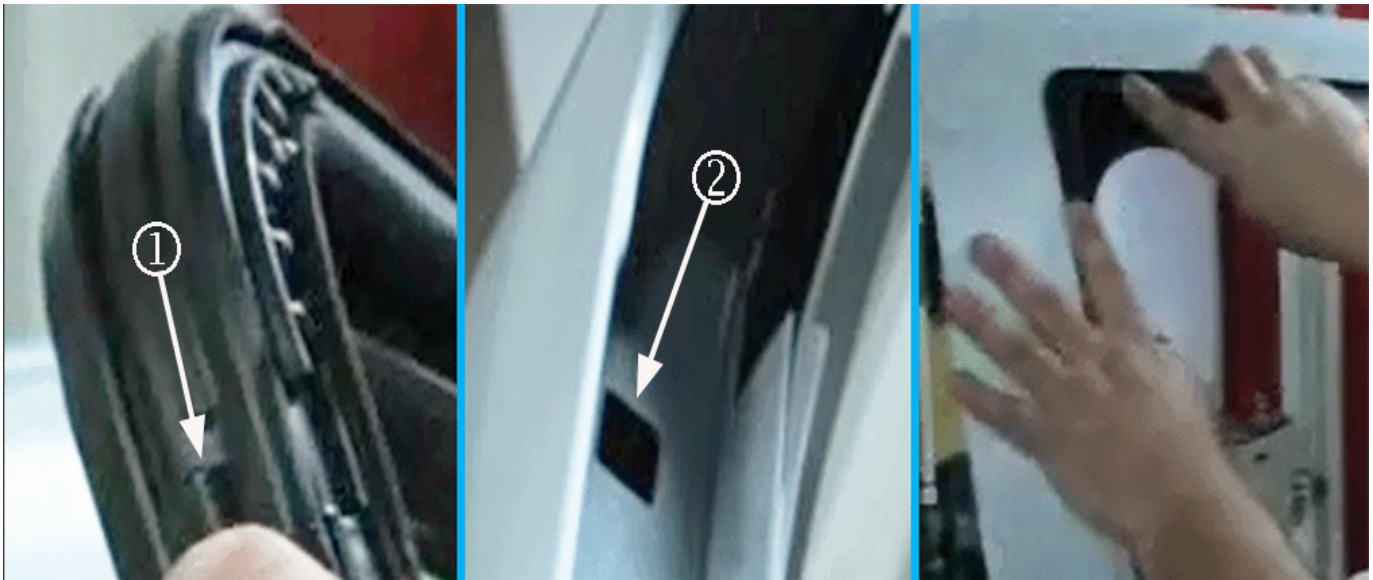

4846299

- 8.2. Starting at the B-pillar upper corner, position the corner locator (1) on the weatherstrip to the hole in the sheet metal (2) and push until locator snaps into place. An audible click should be heard when the locator engages.

**Tip:** Check to verify the weatherstrip is securely in place by lightly pulling down on the rear leg, and looking for any movement at the upper corner.

- 8.3. Fully seat the weatherstrip into the door frame at least a hand-width forward AND downward from the B-pillar corner.



4846303

- 8.5. With front and rear corners in place, starting at the front, fully seat the weatherstrip into position in the door frame header.

**Tip:**

With the weatherstrip legs still loose, any gapping at the header can be adjusted by slightly pulling down on the legs.

- 8.6. Once the header is in proper position, fully seat the weatherstrip at the rear of the door frame.

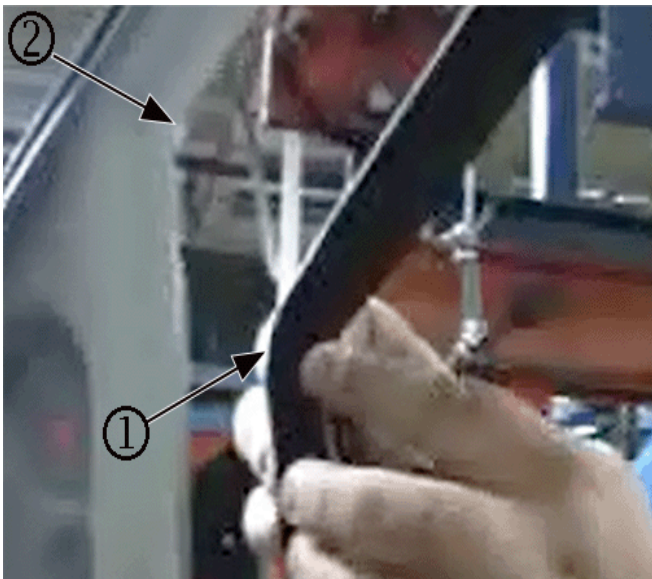

4846302

- 8.4. Moving to the A-pillar, match the corner radius of the weatherstrip (1) to the door frame radius (2), and push into position.



4846306

8.7. Return to the A-pillar and fully seat the front of the weatherstrip down into the window opening. Ensure that the larger front lip is positioned outside the sheet metal.



4846308

8.8. As a final position check from inside the door, ensure the B-pillar upper corner tab of the weatherstrip is centered to the corner of the upper door frame. The weatherstrip should also display a uniform, one to one fit along the complete perimeter of the door frame.

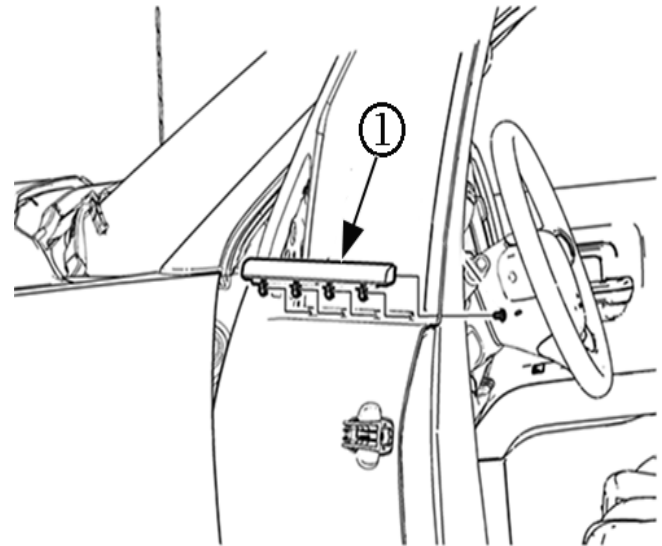

4846278

9. Reinstall the front door trim panel, garnish molding, outside rearview mirror and belt reveal molding. Refer to *Front Side Door Window Belt Reveal Molding Replacement* in SI.

### Parts Information

Description	Part Number	Qty	Contact Information
Kent® Ure-Foam Expandible Foam Sound Deadener*	P 10630	1	Contact Kent Automotive at 1-888-937-5368 or
3M™ Flexible Foam*	08463		
Crest® Flexi Foam (Two Part Flexible Urethane)*	CF-F		
SEM Dual-Mix™ Flexible Urethane Foam*	39357		
Kent® High Tech Clear Seam Sealer*	P 10200	1	Contact Kent Automotive at 1-888-937-5368 or

Description	Part Number	Qty	Contact Information
3M™ Heavy Drip-Chek™ Sealer*	08531		
Crest Clear Drip Seal*	TJ-C		
Würth Euroseal Gel*	08920104		

\*We believe this source and their products to be reliable. There may be additional manufacturers of such products/materials. General Motors does not endorse, indicate any preference for or assume any responsibility for the products or material from this firm or for any such items that may be available from other sources.

## Warranty Information

For vehicles repaired under the Bumper-to-Bumper coverage (Canada Base Warranty coverage), use the following labor operation. Reference the Applicable Warranties section of Investigate Vehicle History (IVH) for coverage information.

Labor Operation	Description	Labor Time	Material Allowance
1411232	Front Side Door Adjustment	Use Published Labor Operation Time	N/A
1480858*	R & R Weatherstrip, Install Foam Sound Deadener and Sealer to Front Door Header	1.2 hrs	Submit actual cost

\*This is a unique Labor Operation for Bulletin use only. It will not be published in the Labor Time Guide.

<b>Version</b>	2
<b>Modified</b>	November 29,2017 — added 2018 Model Year and Updated the Parts Information.

GM bulletins are intended for use by professional technicians, NOT a "do-it-yourselfer". They are written to inform these technicians of conditions that may occur on some vehicles, or to provide information that could assist in the proper service of a vehicle. Properly trained technicians have the equipment, tools, safety instructions, and know-how to do a job properly and safely. If a condition is described, DO NOT assume that the bulletin applies to your vehicle, or that your vehicle will have that condition. See your GM dealer for information on whether your vehicle may benefit from the information.



WE SUPPORT VOLUNTARY  
TECHNICIAN  
CERTIFICATION