



Service Bulletin

File in Section: -

Bulletin No.: 16-NA-051

Date: November, 2017

TECHNICAL

Subject: Active Shutters Inoperative, Malfunction Indicator Lamp (MIL) Illuminated - DTCs P059F, P0071, P0072, P0073, P0074, P3056, U1345, U1501, U1510, U1511 Set

Brand:	Model:	Model Year:		VIN:		Engine:	Transmission:
				from	to		
Buick	LaCrosse	2017	2017				
Chevrolet	Malibu (VIN Z)	2016	2017				

Involved Region or Country	North America and Israel
Additional Options (RPO)	VRI
Condition	<p>Some customers may comment on the Malfunction Indicator Lamp (MIL) being illuminated.</p> <p>The technician may find one or more of the following DTCs set:</p> <ul style="list-style-type: none">• P059F• P0071• P0072• P0073• P0074• P3056• U1345• U1501• U1510• U1511
Cause	This condition may be caused by the following conditions:

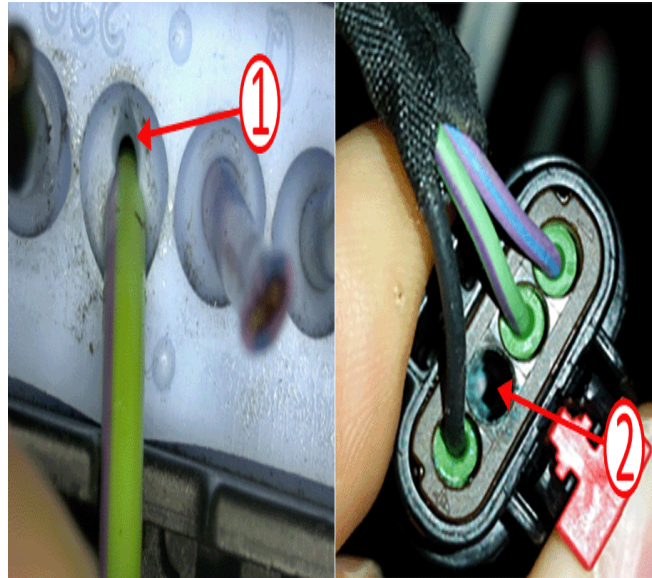

4787001

- Moisture intrusion past damaged (1) and/or missing (2) seals located in the B9, M60B and/or X119 connectors for the ambient air temperature sensor wiring harness.
- Snow and/or ice buildup in the front lower grille area of the vehicle, which could prevent the active aero shutters from opening or closing.

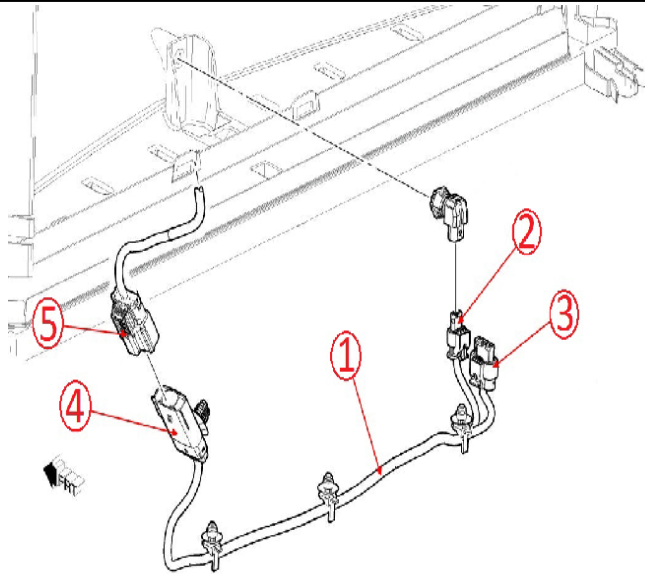

4527562

Correction

Inspect the ambient air temperature sensor wiring harness connectors B9 (2), M60B (3) and the X119 (4, 5) for any signs of corrosion.

Notice: The Ambient Air Temperature Sensor Wiring Harness must be replaced and dielectric grease must be applied to all of the connectors for any of the following repairs.

- If any signs of water and/or corrosion was found on the Ambient Air Temperature Sensor Wiring Harness (1), it must be replaced.
- If water and/or corrosion was found at the X119 connector (5), the main body wiring harness connector must be replaced.
- If water and/or corrosion was found at the B9 connector (2), the ambient air temperature sensor must be replaced.
- If water and/or corrosion was found at the M60B connector (3), the active shutter must be replaced.

If the above inspection did not find any corrosion or damaged seals, and there are signs of previous snow or ice in the active shutter system, explain to the customer that this can occur during certain weather conditions and the MIL will clear when the shutters are in proper working order. It will not impact the designed performance or reliability of the vehicle. Please share this information with the customer, including a copy of this bulletin.

Parts Information

Description	Part Number	Qty
CONNECTOR KIT, WRG HARN	13504371	1
HARNESS, AMB AIR TEMP SEN WRG	23258243	1

Warranty Information

For vehicles repaired under the Bumper-to-Bumper coverage (Canada Base Warranty coverage), use the following labor operation. Reference the Applicable Warranties section of Investigate Vehicle History (IVH) for coverage information.

Labor Operation	Description	Labor Time
5430860	Connector Kit Replacement	Use Published Labor Operation Time
5480328*	Ambient Air Temperature Sensor Wiring Harness - Replacement	0.5 hr
*This is a unique Labor Operation for Bulletin use only.		

Version	5
Modified	August 11, 2016 - Added DTCs and added Ambient Harness and repair. February 7, 2017 - Added the 2017 Model Year for Malibu and LaCrosse model. May 15, 2017 - Updated the Cause and Correction sections. November 17, 2017 - Added additional DTCs to the Condition section.

