



Service Bulletin

INFORMATION

Subject: Information on Availability of Tri-fold Tonneau Cover New Spring Latch Kit

Brand:	Model:	Model Year:		VIN:		Engine:	Transmission:
		from	to	from	to		
Chevrolet	Colorado Silverado	2016	2018			All	All
GMC	Canyon Sierra						

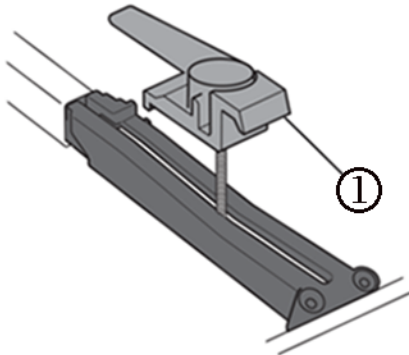
Involved Region or Country	North America, Middle East, Israel, Thailand, Chile
Condition	 <p>Some customers may comment that the tri-fold tonneau cover original quarter turn latch (1) will not turn nor stay latched.</p>
Cause	The cause of the condition may be a broken quarter turn latch.

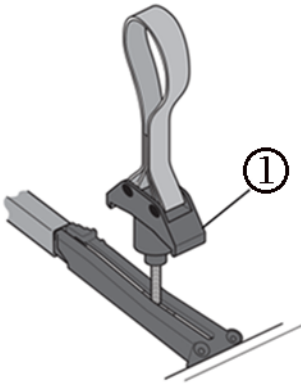
<p>Correction</p>	<div style="text-align: center;">  </div> <p>Replace both original quarter turn tonneau latches with new design spring latches (1) from the appropriate parts kit listed in the Parts table.</p>
--------------------------	--

Parts Information

Note: One kit services full size trucks, the other services mid-size. Each kit includes an individual instruction sheet for installation.

Description	Part Number	Qty
HANDLE, PUBX CVR LAT REL (Full size)	84082763	1 kit
CLAMP KIT-PUBX CVR S/RL (Mid-size)	84203271	1 kit

Warranty Information

For vehicles repaired under the Bumper-to-Bumper coverage (Canada Base Warranty coverage), use the following labor operation. Reference the Applicable Warranties section of Investigate Vehicle History (IVH) for coverage information.

Labor Operation	Description	Labor Time
0580258*	Install Tonneau Cover Latch Handle/Clamp	0.1 hr
*This is a unique Labor Operation for Bulletin use only.		

Version	1
Modified	

GM bulletins are intended for use by professional technicians, NOT a "do-it-yourselfer". They are written to inform these technicians of conditions that may occur on some vehicles, or to provide information that could assist in the proper service of a vehicle. Properly trained technicians have the equipment, tools, safety instructions, and know-how to do a job properly and safely. If a condition is described, DO NOT assume that the bulletin applies to your vehicle, or that your vehicle will have that condition. See your GM dealer for information on whether your vehicle may benefit from this information.

