



Service Bulletin

TECHNICAL

Subject: Clicking Noise from Front While Turning at Low Speeds

Brand:	Model:	Model Year:		VIN:		Engine:	Transmission:
		from	to	from	to		
Cadillac	XT5	2017	2018				
	XTS						
GMC	Acadia (VIN N)						

Involved Region or Country	North America and N.A. Export Regions
Condition	Some customers may comment on a clicking noise from front while turning at slow speed turns.
Cause	This condition may be caused by a loss of torque on the drive axle nut.
Correction	If the above condition has been confirmed, the axle nut and anti-click washer must be replaced.

Parts Information

Description	Part Number	Qty
Washer, FRT WHL DRV SHF	11611965	2
NUT, FRT WHL DRV SHF	11612295	2

Warranty Information

For vehicles repaired under the Bumper-to-Bumper coverage (Canada Base Warranty coverage), use the following labor operation. Reference the Applicable Warranties section of Investigate Vehicle History (IVH) for coverage information.

Labor Operation	Description	Labor Time
3080208*	Install Front Axle Shaft Nut and Washer	1.0 hr

*This is a unique Labor Operation for Bulletin use only.

Service Procedure

Warning: To prevent personal injury and/or component damage, do not allow the weight of the vehicle to load the front wheels, or attempt to operate the vehicle, when the wheel drive shaft(s) or wheel drive shaft nut(s) are removed. To do so may cause the inner bearing race to separate, resulting in damage to brake and suspension components and loss of vehicle control.

1. Remove the front tire and wheel assembly. Refer to *Tire and Wheel Removal and Installation* in SI.

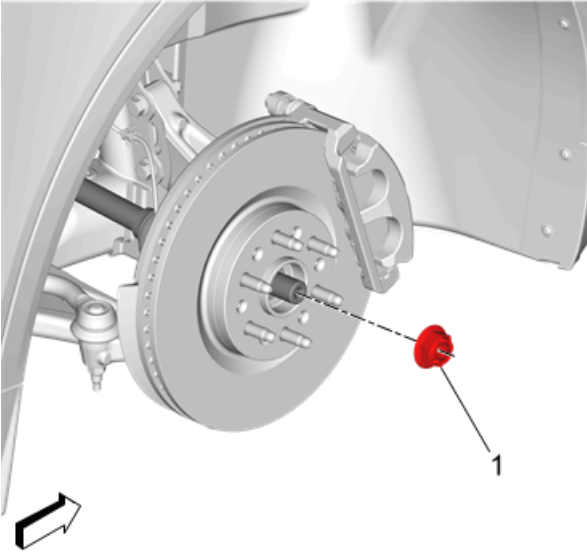

Caution: **DO NOT** use air tools to remove the wheel drive shaft nut. Damage to the wheel drive shaft threads could occur. Use hand tools only.

2. Remove the wheel drive shaft nut (1) and **DISCARD** the nut.
3. Separate the steering linkage outer tie rod from the steering knuckle.

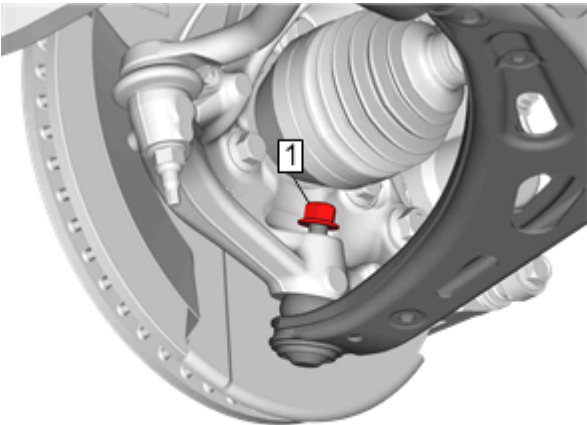

4. Remove the lower ball joint nut (1).
5. Separate the lower control arm from the steering knuckle.

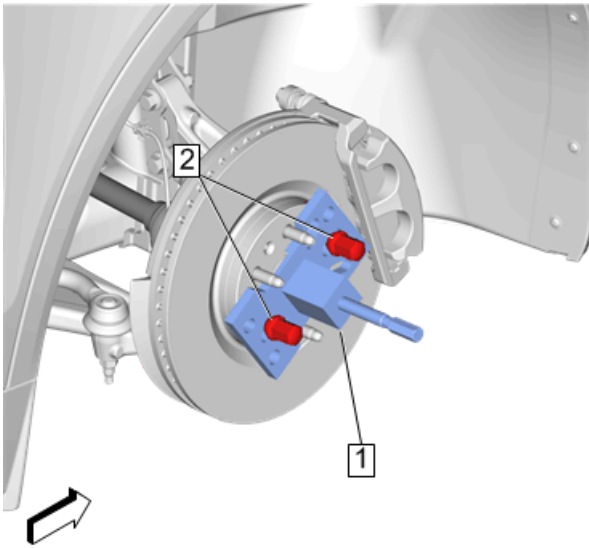

6. Attach the J-45859 remover (1) to the wheel hub using the wheel lug nuts (2).
7. Using the J-45859 remover, separate the wheel drive shaft from the wheel bearing/hub.

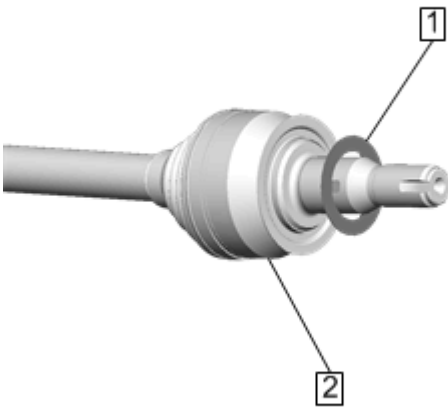

8. Remove the washer (1) from the wheel drive shaft (2) and **DISCARD** the washer.
9. Position the new washer onto the wheel drive shaft.
10. Using care, install the drive shaft into the hub.
11. Install the steering knuckle onto the lower control arm.
 - Tighten the fastener to specifications. Refer to Fastener Specifications in SI.
12. Install the outer tie rod to the steering knuckle.
 - Tighten the fastener to specifications. Refer to Fastener Specifications in SI.

Note: **DO NOT** use air tools to tighten the wheel drive shaft nut. Tighten the **NEW** wheel drive shaft nut slowly to draw the wheel drive shaft into the hub assembly prior to tightening to specifications.

13. Install new axle nut to drive shaft.
14. With the aid of an assistant holding the brake pedal down, tighten the NEW wheel drive shaft nut.
 - 14.1. First Pass: **150 Y (111 lb ft)**
 - 14.2. Second Pass: **Loosen 45 degrees**
 - 14.3. Final Pass: **270 Y (199 lb ft)**
15. Install the front tire and wheel assembly. Refer to *Tire and Wheel Removal and Installation* in SI.

Version	2
Modified	May 30, 2017 - Added the 2018 Model Year and XTS model.

GM bulletins are intended for use by professional technicians, NOT a "do-it-yourselfer". They are written to inform these technicians of conditions that may occur on some vehicles, or to provide information that could assist in the proper service of a vehicle. Properly trained technicians have the equipment, tools, safety instructions, and know-how to do a job properly and safely. If a condition is described, DO NOT assume that the bulletin applies to your vehicle, or that your vehicle will have that condition. See your GM dealer for information on whether your vehicle may benefit from this information.



WE SUPPORT VOLUNTARY TECHNICIAN CERTIFICATION