



Service Bulletin

TECHNICAL

Subject: Poor Engine Performance in Extremely Cold Weather Conditions, PCV Bypass Hose and Charge Air Cooler Icing, Malfunction Indicator Lamp (MIL) Illuminated - DTC P0299, P0236, P2227, P00C7 Set

Brand:	Model:	Model Year:		VIN:		Engine:	Transmission:
		from	to	from	to		
Buick	Encore	2013	2017			1.4L (LUV)	
Chevrolet	Trax						

Involved Region or Country	North America
Condition	<p>Some customers may comment that when driving short distances and/or slow speed driving cycles, their vehicle experiences one or several of the following conditions within the first 10 to 15 minutes of vehicle operation in extremely cold weather conditions (-18°C or less / 0°F or less):</p> <ul style="list-style-type: none"> • Loss of power. • Smoke out the tail pipe. • Hesitation on acceleration. • Stalling condition. • Burning oil odor possibly caused by oil leak. • May also notice a Malfunction Indicator Lamp illuminated. • After driving for a period of time, the driveability issues seem to diminish. • Malfunction Indicator Light Illuminated. <p>This condition may also cause an increase in crankcase pressure, creating oil leaks at seals and gaskets.</p> <p>The technician may find one or more of the following DTCs set:</p> <ul style="list-style-type: none"> • P0299 • P0236 • P2227 • P00C7

Cause

This condition may be caused by one or more of the following:

- Plugged Crank Case Vent tube from ice forming in the tube during very cold weather conditions.
- Ice accumulation in the charge air cooler restricting air flow to the throttle body.

Correction

Important: The PCV heater parts are only to be used in northern states or provinces that temperatures are -18°C or less / 0°F or less and for critical customers only.

An oil change is necessary to remove any moisture from the engine.

PCV Heater Service Procedure

1. Remove the battery. Refer to *Battery Replacement* in SI.
2. Remove engine cover.

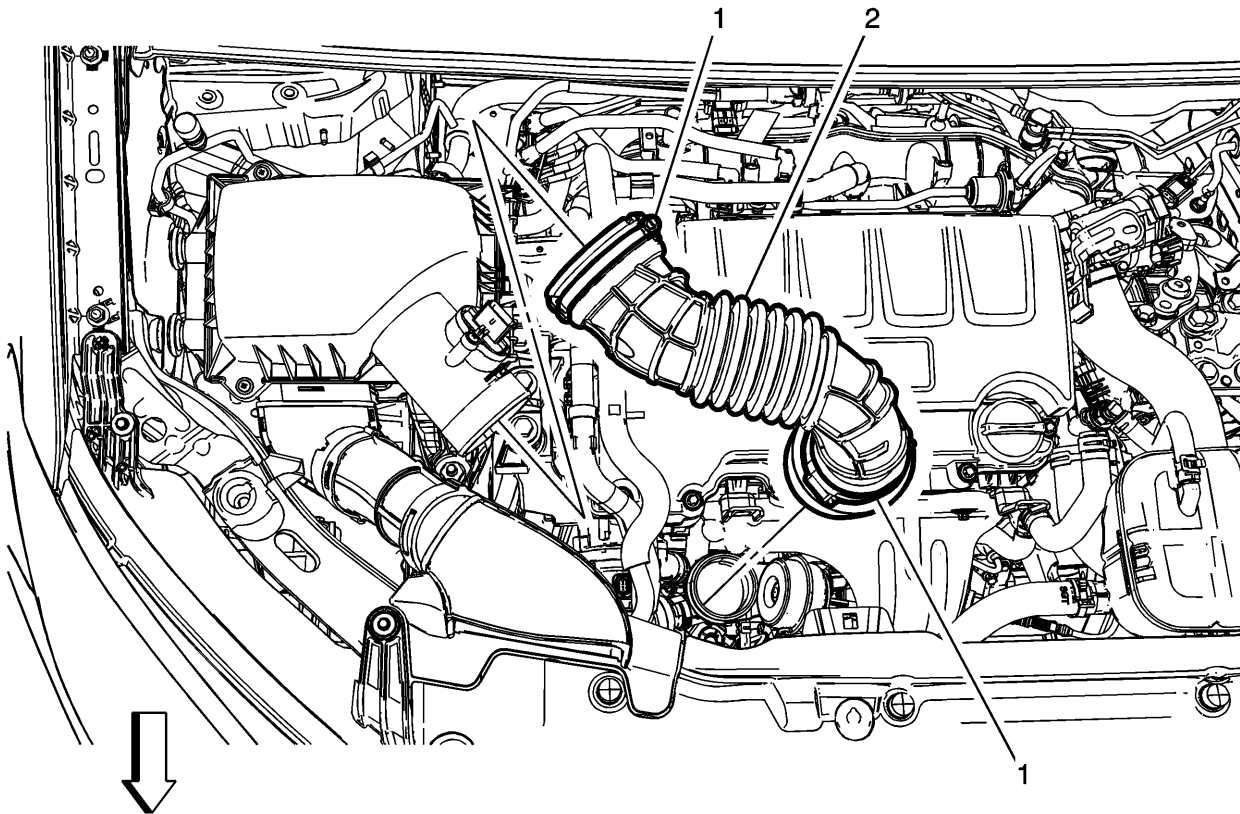

3. Remove and discard the air cleaner outlet duct (2) and resonator.

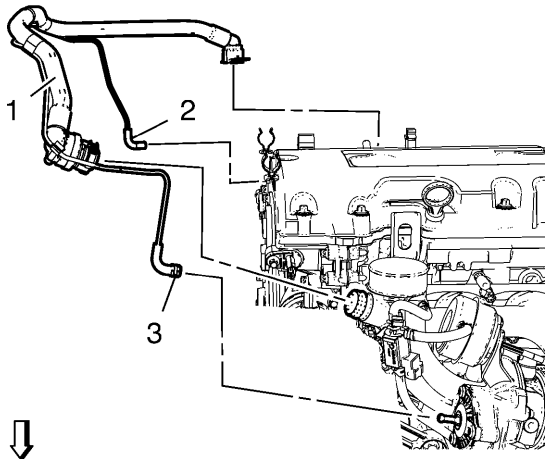

4. Remove and discard the Positive Crankcase Ventilation Hose/Pipe/Tube (1) and vacuum line. Refer to *Positive Crankcase Ventilation Hose/Pipe/Tube Replacement* in SI.

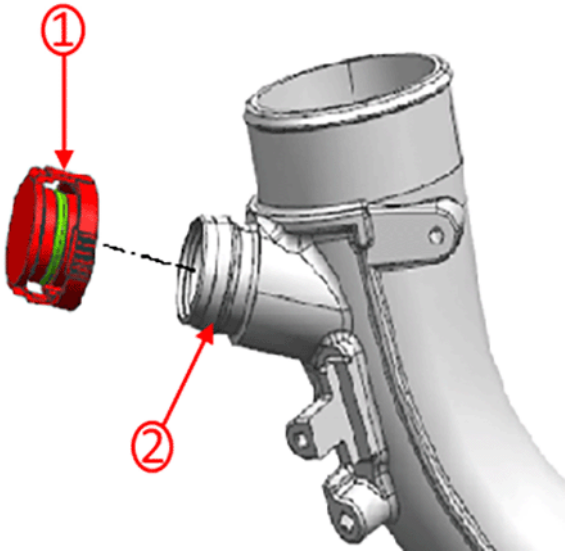

5. Install the block off plug (1) onto the turbocharger bypass port (2).

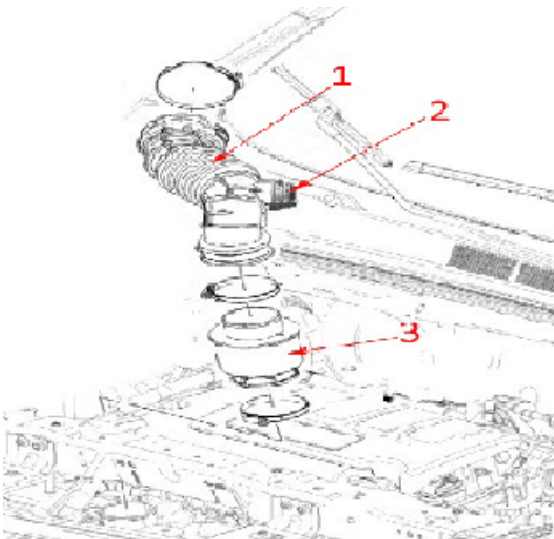

6. Install the new air resonator (3).

7. Install the new air cleaner outlet duct (1).
8. Install the new PCV pipe assembly.
9. Install the PCV heater into air cleaner outlet duct (2).

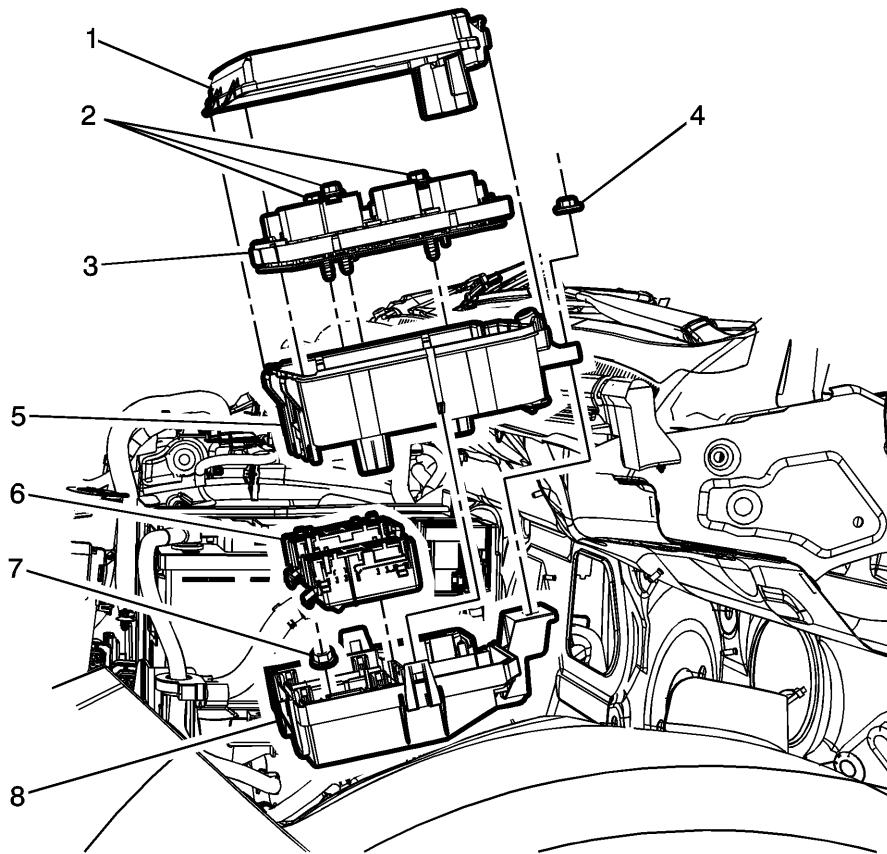

10. Remove the fuse block cover (1).
11. Remove the nut (4) that secures the upper fuse block to the body.
12. Loosen the three upper connector bolts (2).
13. Separate the upper (5) fuse block assembly from the fuse block base (8) by releasing the snap locks. Refer to *Front Compartment Fuse Block Replacement* in SI.
14. Route the PCV wiring harness under the battery tray.

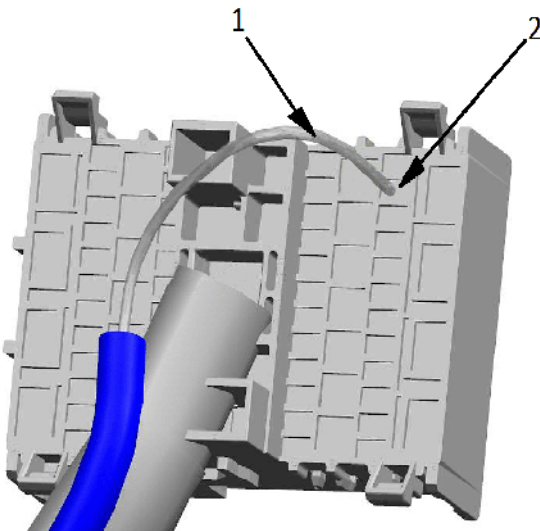

15. For 2013-2016 model vehicles:

- 15.1. Remove UEX_X2 connector from the fuse block base.
- 15.2. Install PCV heater wiring harness terminal (1) into the J11 cavity (2).
- 15.3. Route the wiring harness between the battery and fuse block.

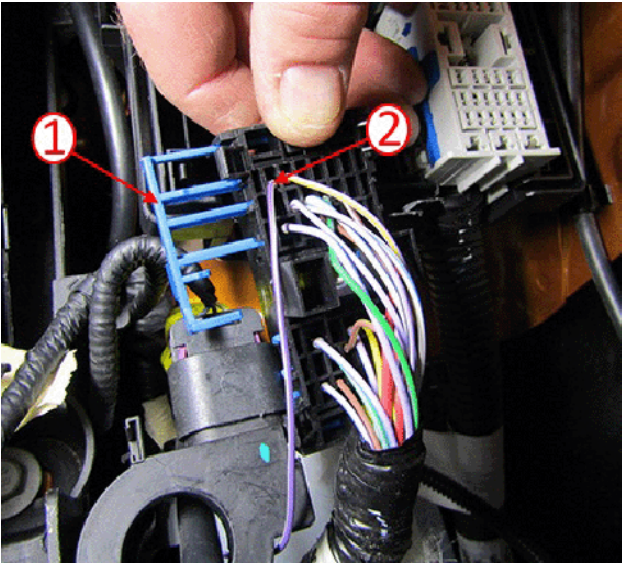

16. For 2017 model vehicles:

- 16.1. Remove the UEX_X3 connector from the fuse block base.
- 16.2. Remove the X3 connector cover.
- 16.3. Remove connector lock (1).
- 16.4. Install PCV heater wiring harness terminal into the H6 cavity (2).

- 17. Using tie straps, fasten the PCV wiring harness to the connectors wiring harness at the white tape indicators.
- 18. Install the connector back onto the fuse block base.

Important: Only replace the fuse and install the labels on vehicles that have a 5 amp fuse. Some vehicles have the 10 amp fuse already installed and do not require replacement or the label.

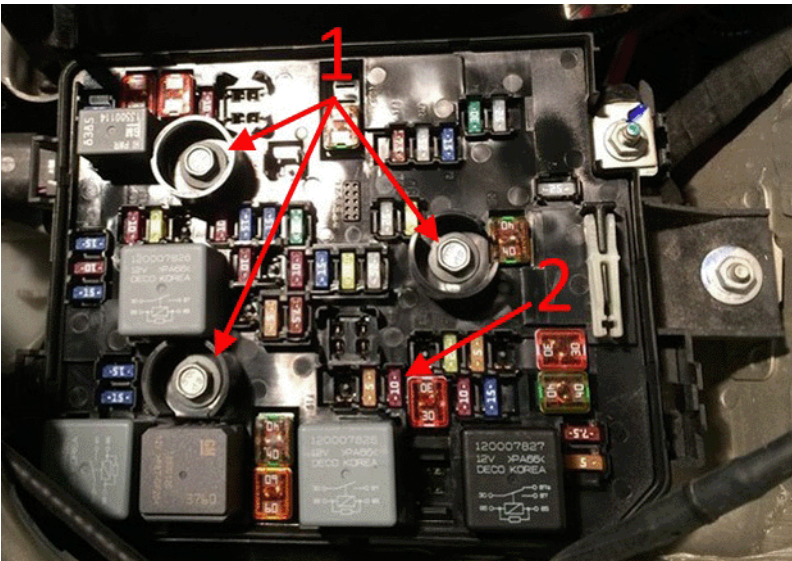

- 19. Position and snap the upper fuse block onto the base.
Tighten: Torque the bolts (1) to specifications. Refer to *Fastener Specifications* in SI.
- 20. If necessary, replace the 5 amp fuse with a 10 amp fuse into cavity F17 (2).

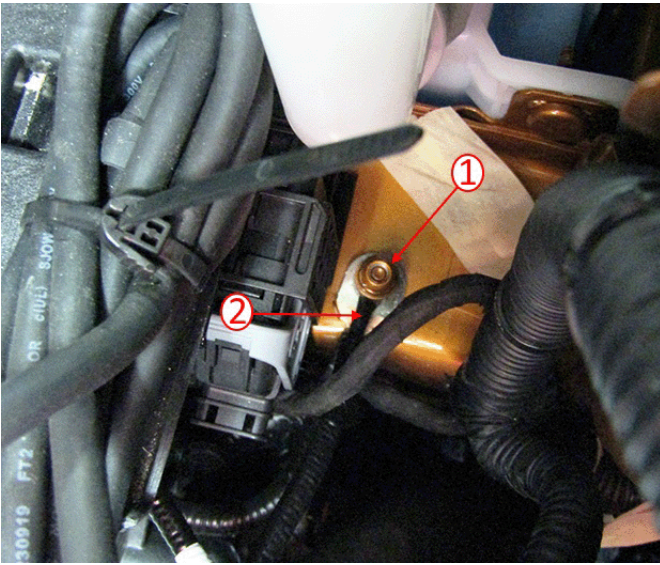

21. Install the PCV heater wiring harness ground (2) to an existing ground located at the frame stud (1).

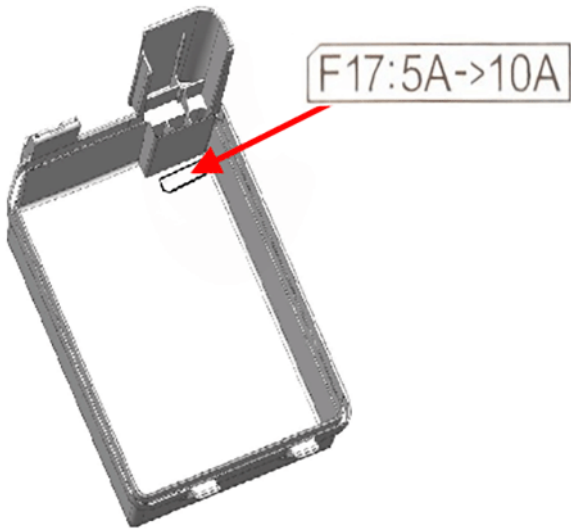

22. Install the UEC sticker onto the backside of the fuse block cover and in the owners manual under Engine Compartment Fuse Block.

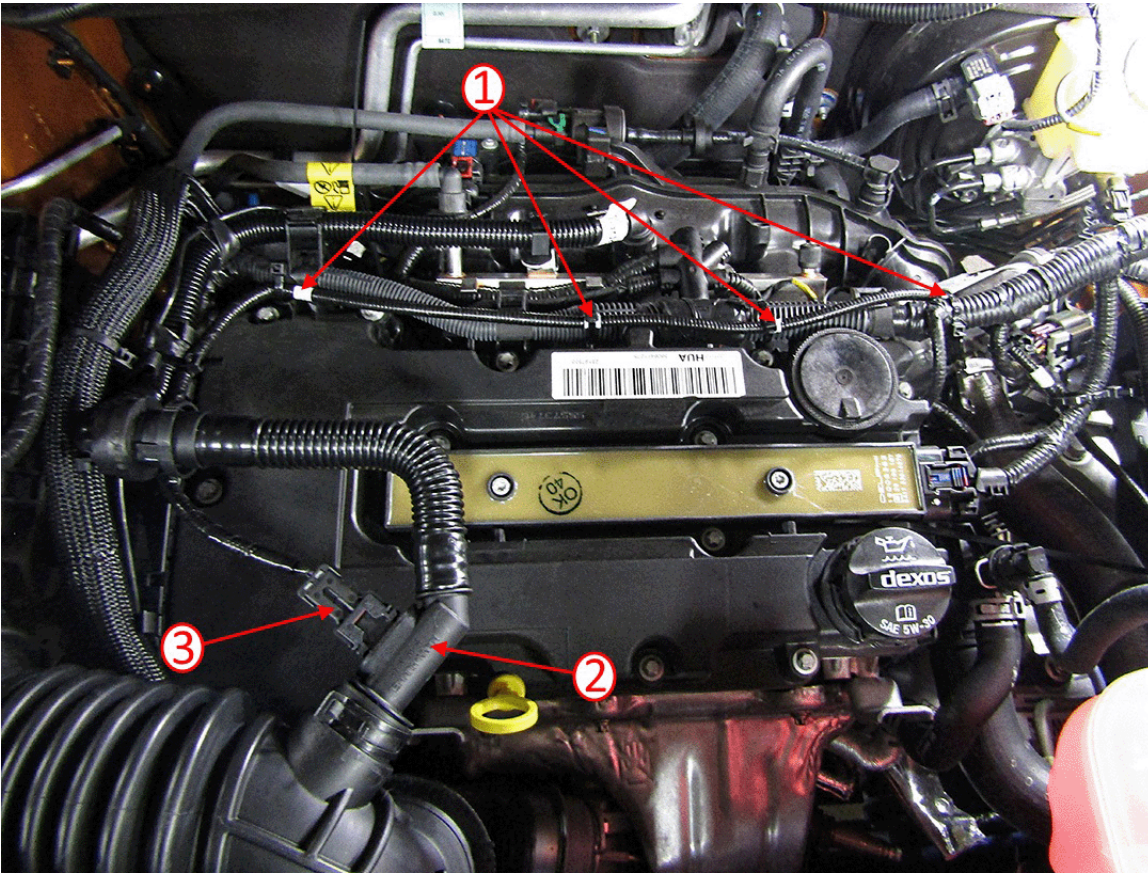

23. Route the PCV heater wiring harness across the engine wiring harness.
24. Using the tie straps, fasten the wiring harness at the white marking points (1).
25. Connect the electrical connector (3) to the PCV heater (2).
26. Perform an oil change. Refer to *Engine Oil and Oil Filter Replacement* in SI.

Note: Allow the Charge Air Cooler to warm up to room temperature so that any moisture can be drained.

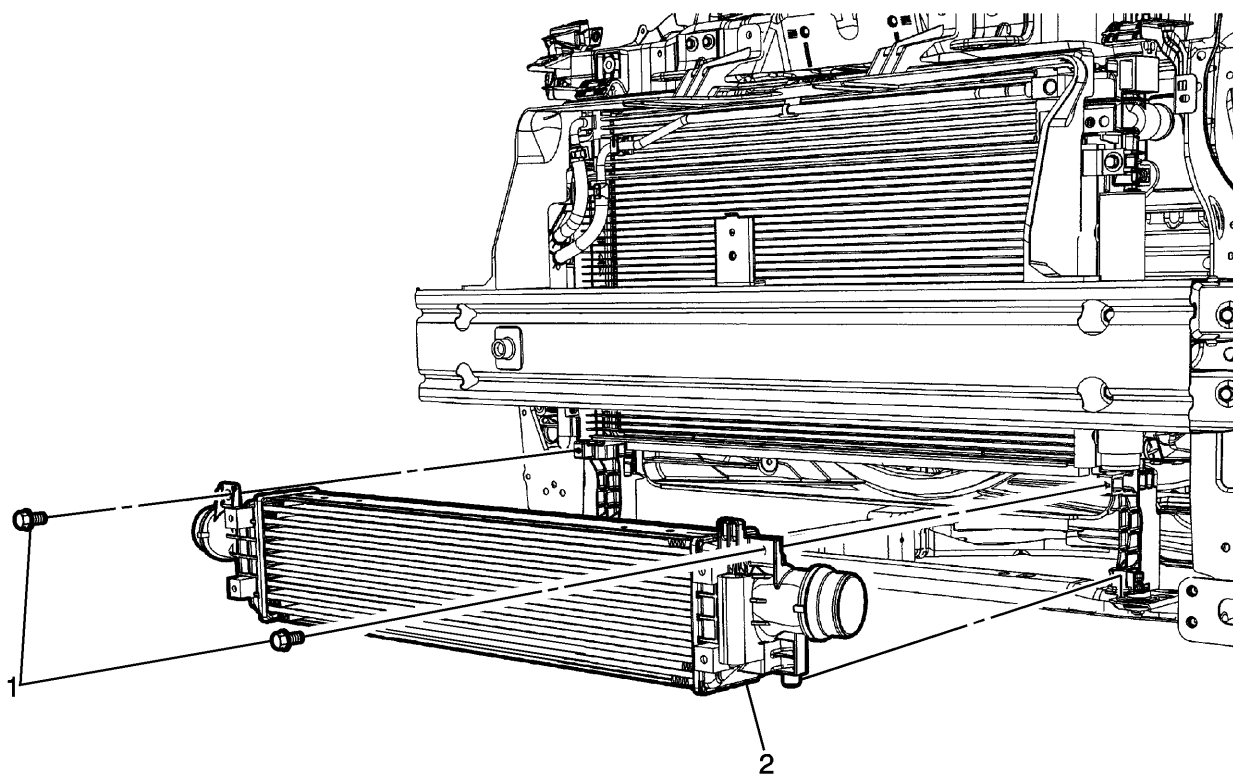

27. Remove the CAC (2). Refer to *Charge Air Cooler Replacement* in SI.

28. Drain water moisture from the CAC.

29. Install the CAC.

Parts Information

Description	Model Year	Part Number	Qty
Kit, PCV Heater	2013-2016	25198125	1
Kit, PCV Heater	2017	25198126	1
Filter, Oil	2013-2017	Refer to the Electronic Parts Catalog (EPC).	
Oil			

Warranty Information

For vehicles repaired under warranty, use:

Labor Operation	Description	Labor Time
4081358*	PCV Heater and Wiring Harness Installation	1.0 hr
Add	Charge Air Cooler Removal, Drain and install	1.0 hr
Add	Oil Change	0.3 hr

*This is a unique Labor Operation for Bulletin use only.

Version	4
Modified	<p>Dec. 23, 2016 - Added DTCs to the Condition and a Note to the Parts Information.</p> <p>Jan. 5, 2017 - Removed Fascia Blocker information.</p> <p>Jan. 23, 2017 - Added steps to end of Service Procedure for draining the CAC and updated Warranty Information.</p>

GM bulletins are intended for use by professional technicians, NOT a "do-it-yourselfer". They are written to inform these technicians of conditions that may occur on some vehicles, or to provide information that could assist in the proper service of a vehicle. Properly trained technicians have the equipment, tools, safety instructions, and know-how to do a job properly and safely. If a condition is described, DO NOT assume that the bulletin applies to your vehicle, or that your vehicle will have that condition. See your GM dealer for information on whether your vehicle may benefit from this information.



WE SUPPORT VOLUNTARY TECHNICIAN CERTIFICATION