

Mirai Hydrogen Supply Regulator Noise

Service Category Engine/Hybrid System

Section Fuel System

Market USA

Toyota Supports
 ASE Certification 

Applicability

YEAR(S)	MODEL(S)	ADDITIONAL INFORMATION
2016 - 2017	Mirai	

Introduction

Some 2016 – 2017 model year Mirai vehicles may exhibit a chirp noise coming from the rear of the vehicle during the following conditions:

- Low/parking lot speeds
- Cruising speeds
- Varying angles of accelerator pedal application

[Chirp Noise Example](#)

This chirp noise may come from the hydrogen supply regulator. Follow the Repair Procedure in this bulletin to address this condition.

Warranty Information

OP CODE	DESCRIPTION	TIME	OFF	T1	T2
EG1658	Silencer Pad Installation and Hydrogen Pressure Release Operation	2.0	77AC0-62020	91	43

APPLICABLE WARRANTY

- This repair is covered under the Toyota Basic Warranty. This warranty is in effect for 36 months or 36,000 miles, whichever occurs first, from the vehicle's in-service date.
- Warranty application is limited to occurrence of the specified condition described in this bulletin.

Mirai Hydrogen Supply Regulator Noise

Parts Information

PART NUMBER	PART NAME	QTY
67811-AA040	Pad, FR Door Silence	17
90301-11036	Ring, O	1
90301-09037		1
08887-02909	Toyota Genuine FC Grease	As Needed

Required Tools & Equipment

SPECIAL SERVICE TOOLS (SST)	PART NUMBER	QTY
Digital Hydrogen Gas Detector*	01215-00101	1
Hydrogen Gas Detector Adapter*	09401-62010	1

* Essential SST.

NOTE

Additional SSTs may be ordered by calling 1-800-933-8335.

Repair Procedure

NOTICE

BEFORE performing this procedure, ensure that the code compliant facility for hydrogen repair has been approved with the local Authority Having Jurisdiction (AHJ). It is a requirement for this procedure to be performed in a code compliant facility.

1. Confirm that the chirp noise is coming from the hydrogen supply regulator.
Is the chirp noise coming from the hydrogen supply regulator?
 - **YES** — Continue to step 2.
 - **NO** — This bulletin does NOT apply. Continue diagnosis using the applicable Repair Manual.
2. Disconnect the negative (–) terminal of the auxiliary battery.
Refer to the Technical Information System (TIS), applicable model and model year Repair Manual:
 - 2016 – 2017 Mirai:
General – Maintenance – [“Maintenance: Auxiliary Battery: Removal”](#)

Mirai Hydrogen Supply Regulator Noise

Repair Procedure (Continued)

3. Install the silence pads under the rear seat.
 - A. Remove the rear seat assembly.

NOTE

If an under seat clip is needed, use P/N 72693-12080, Rear Seat Cushion Lock Hook.

Refer to TIS, applicable model and model year Repair Manual:

- 2016 – 2017 Mirai:
 Vehicle Interior – Seat – [“Seat: Rear Seat Assembly: Removal”](#)

- B. Wipe the seat area clean BEFORE installing the pads.
- C. Install the silence pads under the rear seats in the locations shown.

Figure 1. Passenger Side

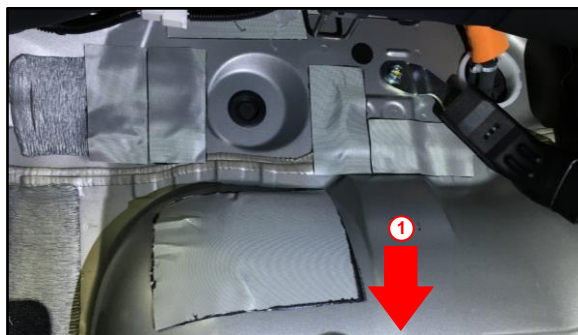
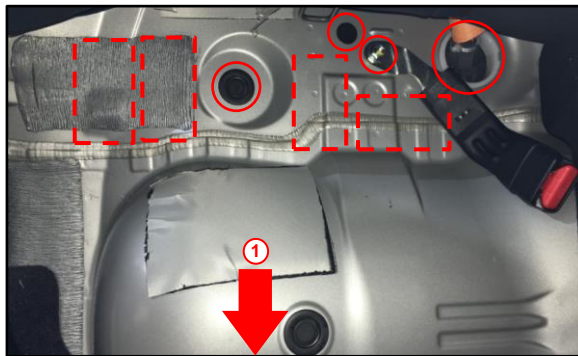

1	Front
---	-------

Figure 2. Driver Side

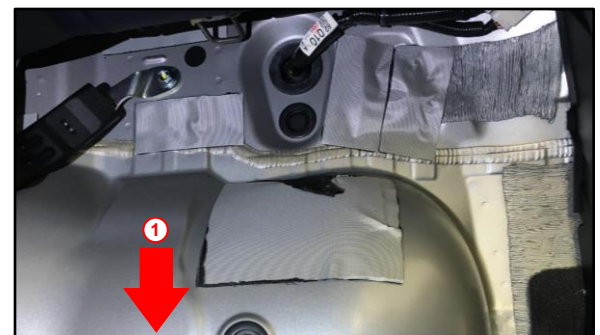
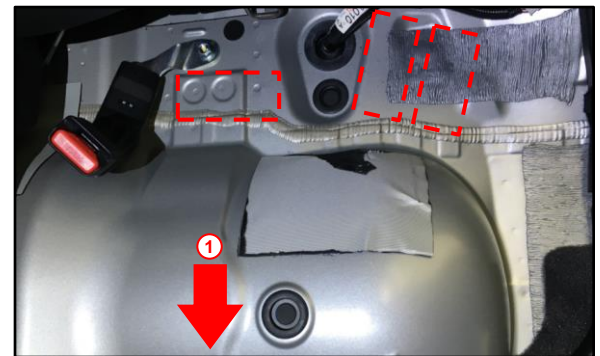

1	Front
---	-------

NOTE

- Keep the silence pads AT LEAST 5 mm away from the edge of the seat belt mounting brackets.
- Keep the silence pads AT LEAST 5 mm away from the edge of the grommets.
- Do NOT overlap the silence pads.

Mirai Hydrogen Supply Regulator Noise

Repair Procedure (Continued)

4. Install the rear seat assembly.

Refer to TIS, applicable model and model year Repair Manual:

- 2016 – 2017 Mirai:

Vehicle Interior – Seat – [“Seat: Rear Seat Assembly: Installation”](#)

5. Install the silence pads in the luggage area.

- A. Remove the luggage compartment interior trim covers.

Refer to TIS, applicable model and model year Repair Manual:

- 2016 – 2017 Mirai:

Vehicle Exterior – Door/Hatch – [“Door / Hatch: Fuel Lid Opener Motor Assembly: Removal”](#)

- 2016 – 2017 Mirai:

Engine/Hybrid System – Hybrid/Battery Control – [“Hybrid / Battery Control: HV Battery: Removal”](#)

Mirai Hydrogen Supply Regulator Noise

Repair Procedure (Continued)

- B. Wipe the luggage area clean BEFORE installing the pads.
- C. Install the silence pads in the locations shown.

NOTE

- Keep the silence pads AT LEAST 5 mm away from the edge of the grommets.
- Do NOT overlap the silence pads.
- Do NOT cover the mounting brackets.

Figure 3.



Figure 4. Rear LH Luggage Compartment

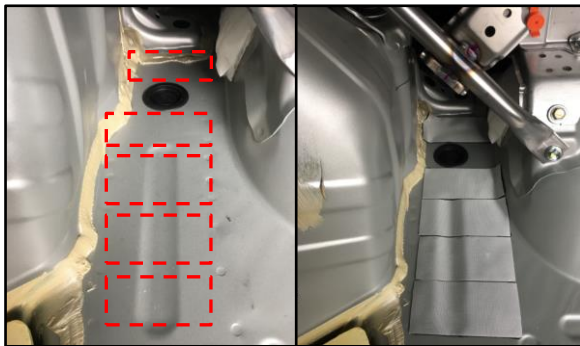
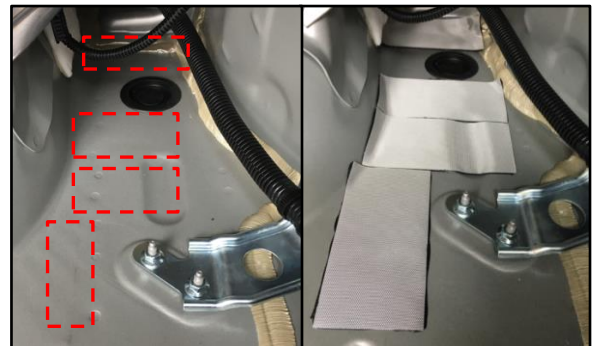

Figure 5. Rear RH Luggage Compartment



Mirai Hydrogen Supply Regulator Noise

Repair Procedure (Continued)

- D. Install the luggage compartment interior trim covers.
Refer to TIS, applicable model and model year Repair Manual:
 - 2016 / 2017 Mirai:
Vehicle Exterior – Door/Hatch – [“Door / Hatch: Fuel Lid Opener Motor Assembly: Installation”](#)
 - 2016 – 2017 Mirai:
Engine/Hybrid System – Hybrid/Battery Control – [“Hybrid / Battery Control: HV Battery: Installation”](#)
6. Install the silence pads on the hydrogen supply regulator.
 - A. Remove the under vehicle covers.
Refer to TIS, applicable model and model year Repair Manual:
 - 2016 – 2017 Mirai:
Engine/Hybrid System – Intake/Exhaust – [“Intake / Exhaust: Exhaust Pipe: Removal”](#)
 - B. Cut one silence pad into two 50 mm X 60 mm pieces.
 - C. Clean the hydrogen supply regulator frame BEFORE installing the pads.
 - D. Install the silence pads on the hydrogen supply regulator frame in the locations shown.

Figure 6. Hydrogen Supply Regulator Frame Installation Locations

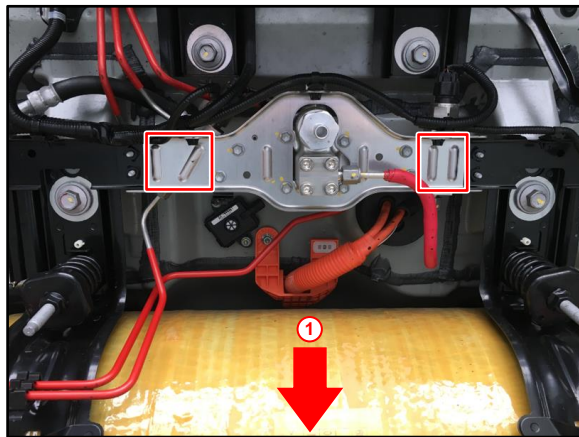

1	Front
----------	--------------

Figure 7. Hydrogen Supply Regulator Frame With Silence Pads Installed

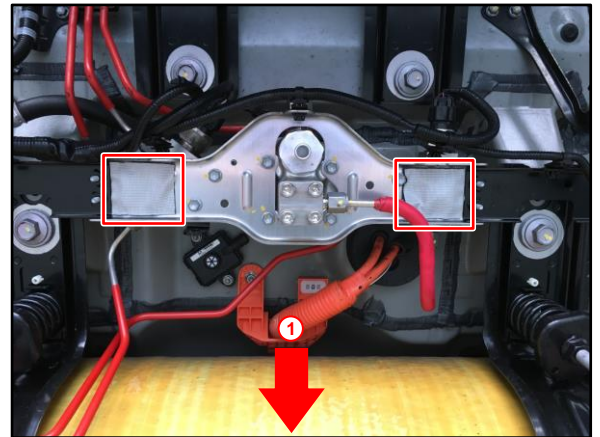

1	Front
----------	--------------

Mirai Hydrogen Supply Regulator Noise

Repair Procedure (Continued)

7. Perform pressure release operation.
 - A. Remove the Fuel Cell (FC) exhaust tail pipe assembly and the No. 3 FC exhaust pipe. Refer to TIS, applicable model and model year Repair Manual:

- 2016 – 2017 Mirai:
Engine/Hybrid System – Intake/Exhaust – [“Intake / Exhaust: Exhaust Pipe: Removal”](#)

NOTICE

Review ALL Hints, Notices, and Cautions in the Repair Manual for hydrogen safety.

- B. Close the manual valves for the No. 1 and No. 2 hydrogen tank assembly.

- (1) Using an 8 mm socket hexagon wrench, rotate the adjustment bolt in a clockwise direction to close the manual valve of the No. 1 hydrogen tank assembly.

Torque: 20 N*m (204 kgf*cm, 15 ft*lbf)

NOTICE

- The manual valve shuts OFF the pressure from the hydrogen tank assembly. Be careful not to damage the hexagonal portion.
- If the hexagonal portion has been damaged, the No. 1 hydrogen tank assembly **MUST** be replaced.

Figure 8.

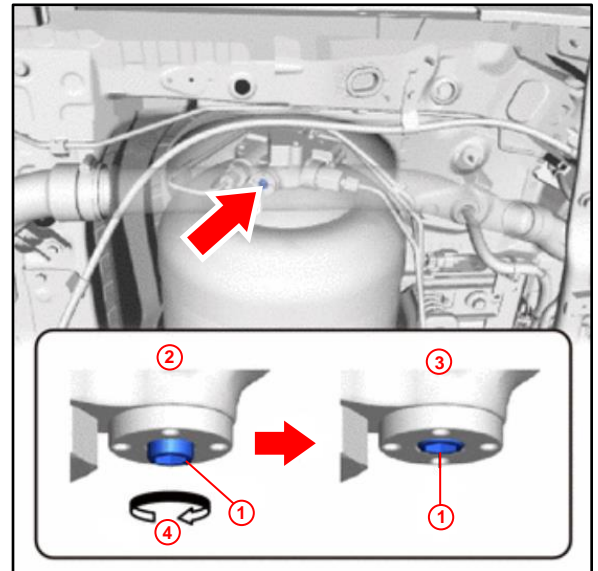

1	Adjustment Bolt
2	Manual Valve Open
3	Manual Valve Closed
4	Clockwise

Mirai Hydrogen Supply Regulator Noise

Repair Procedure (Continued)

- (2) Using an 8 mm socket hexagon wrench, rotate the adjustment bolt in a clockwise direction to close the manual valve of the No. 2 hydrogen tank assembly.

Torque: 20 N*m (204 kgf*cm, 15 ft*lbf)

NOTICE

- The manual valve shuts OFF the pressure from the hydrogen tank assembly. Be careful not to damage the hexagonal portion.
- If the hexagonal portion has been damaged, the No. 2 hydrogen tank assembly MUST be replaced.

Figure 9.

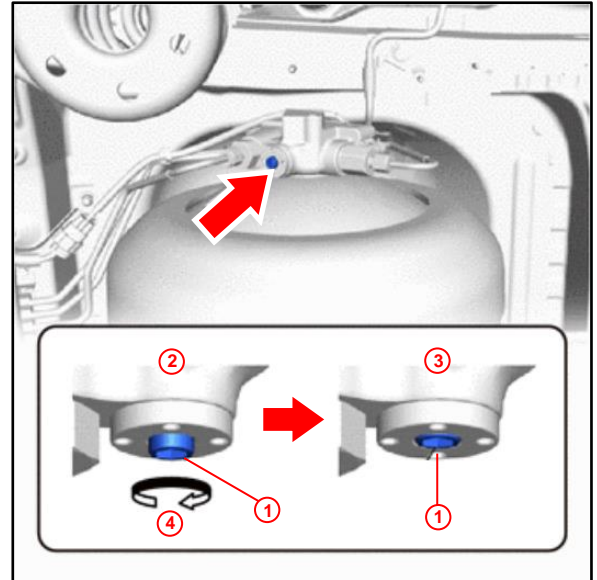

1	Adjustment Bolt
2	Manual Valve Open
3	Manual Valve Closed
4	Clockwise

- (3) BEFORE beginning pressure release procedures, if there are ANY contaminants such as mud near the medium pressure leak check port of the hydrogen supply regulator assembly, clean them away.

CAUTION

Performing installation while ANY foreign matter is adhered to the No. 1 hydrogen supply regulator plug could cause a hydrogen gas leak.

Mirai Hydrogen Supply Regulator Noise

Repair Procedure (Continued)

- C. Perform depressurization.
 - (1) Apply paint marks to the hydrogen supply regulator union and the body of the hydrogen supply regulator assembly.

HINT

When loosening the No. 1 hydrogen supply regulator plug, there is a possibility that the hydrogen supply regulator union could turn together with it and be loosened, so applying paint marks will enable judgment of whether the hydrogen supply regulator union has been loosened.

Figure 10.

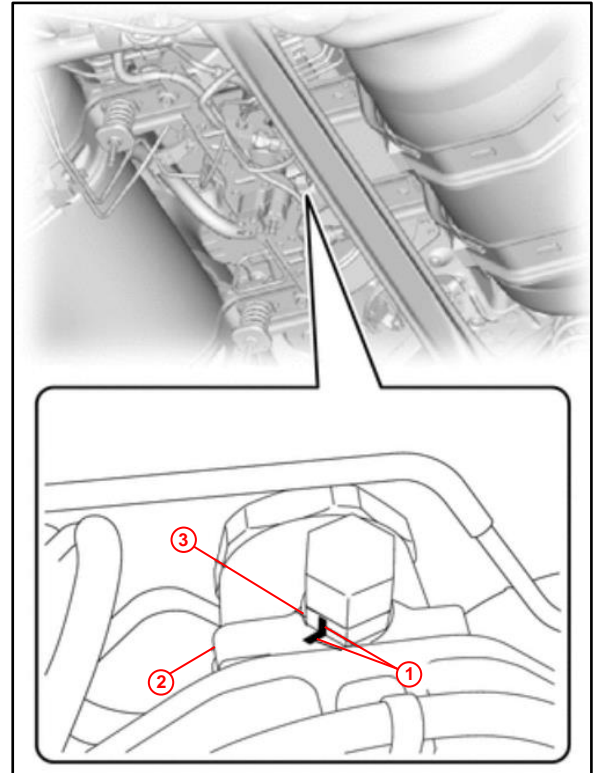

1	Paint Mark
2	Body
3	Hydrogen Supply Regulator Union

Mirai Hydrogen Supply Regulator Noise

Repair Procedure (Continued)

- (2) In order to depressurize the compressed hydrogen gas from the medium pressure leak check port of the hydrogen supply regulator assembly, slowly loosen the No. 1 hydrogen supply regulator plug until the hissing sound of gas escaping can be heard, then stop loosening the No. 1 hydrogen supply regulator plug and wait for the sound to stop. Repeat this procedure until the sound stops occurring.

Figure 11.

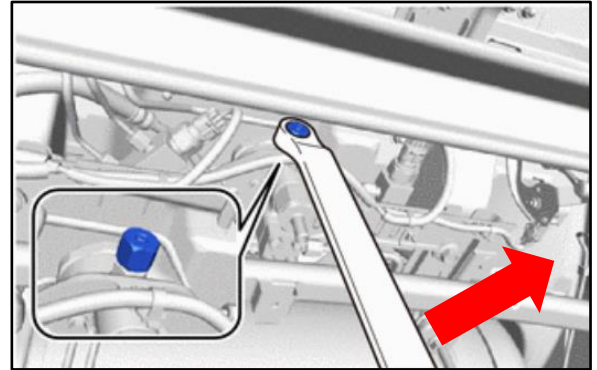

CAUTION

- Do NOT perform depressurization procedures when the manual valve of the hydrogen tank assembly is open.
- The highly pressurized hydrogen gas inside the hydrogen tank assembly could blow out, resulting in a serious accident.
- When performing depressurization, do NOT perform procedures by hand without wearing protective glasses and gloves.

NOTICE

When performing depressurization, ONLY loosen the No. 1 hydrogen supply regulator plug. Do NOT remove it.

- D. Blow compressed air at the underside of the vehicle to disperse ANY accumulated hydrogen gas.

Figure 12.

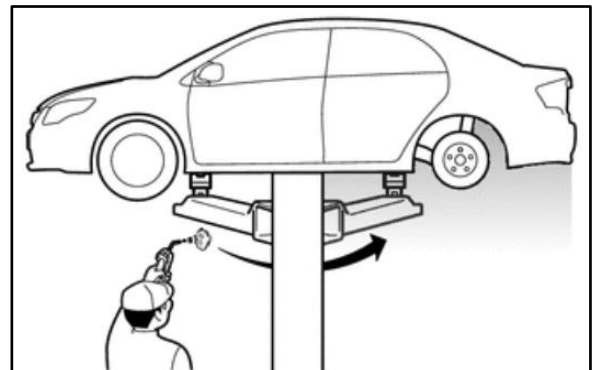

- E. Remove the No. 1 hydrogen supply regulator plug from the hydrogen supply regulator union.

Mirai Hydrogen Supply Regulator Noise

Repair Procedure (Continued)

- F. Remove the O-ring from the hydrogen supply regulator union.

Figure 13.

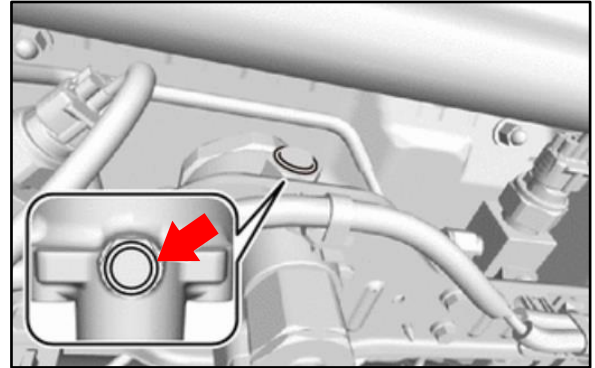

NOTICE

To prevent damage to the seal portions and threaded portions, and to prevent foreign matter such as dust or metal fragments from entering the openings, cover the seal portions, threaded portions, and openings of the hydrogen supply regulator union with protective tape.

Figure 14.

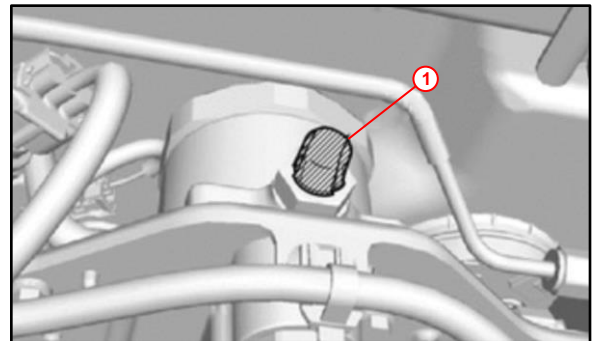

1	Protective Tape
----------	-----------------

Mirai Hydrogen Supply Regulator Noise

Repair Procedure (Continued)

- G. Check that the hydrogen supply regulator union has NOT been loosened.

CAUTION

If the hydrogen supply regulator union has been loosened, there is the possibility of a compressed hydrogen gas leak, so it is necessary to remove the hydrogen supply regulator union and replace the O-ring with a NEW one.

Figure 15. Correct

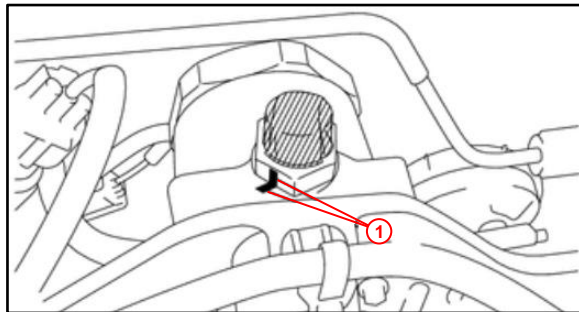

1	Paint Mark
---	------------

Figure 16. Incorrect

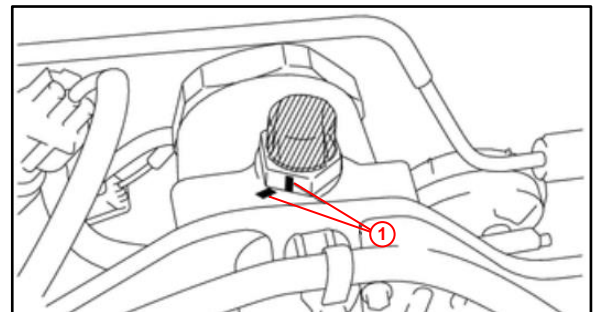

1	Paint Mark
---	------------

Did the hydrogen supply regulator loosen?

- **YES** — Continue to step H.
- **NO** — Go to step I.

- H. Replace the hydrogen supply regulator union O-ring.

- (1) Remove the hydrogen supply regulator union.

Figure 17.

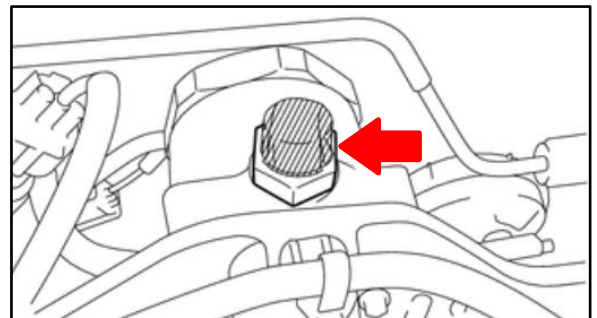

Mirai Hydrogen Supply Regulator Noise

Repair Procedure (Continued)

NOTICE

To prevent foreign matter such as dust or metal fragments from entering the openings, cover the seal portions, threaded portions and, openings of the hydrogen supply regulator union installation portion with protective tape.

- (2) Remove the O-ring from the hydrogen supply regulator union.

NOTICE

Perform this procedure by hand. Do NOT use ANY tools.

- (3) Clean and degrease the threaded portion of the hydrogen supply regulator union.

NOTICE

To prevent the O-ring from being damaged during installation, apply protective tape.

HINT

Cover the hydrogen supply regulator union with protective tape so that the threaded portion and the hole CANNOT be seen.

Figure 18.

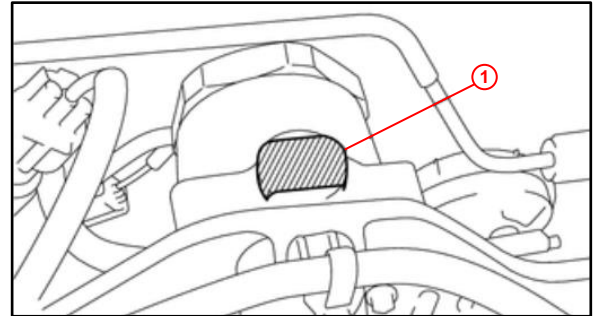

1	Protective Tape
---	-----------------

Figure 19.

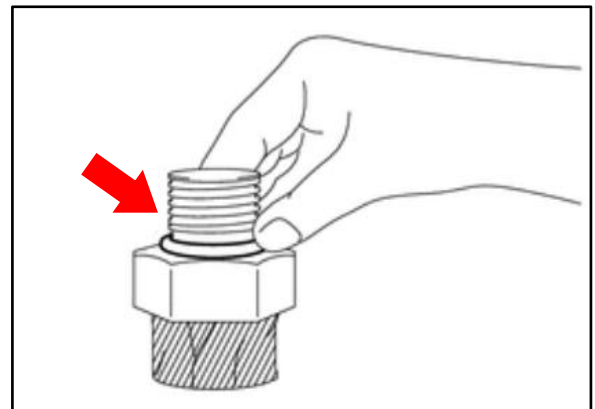
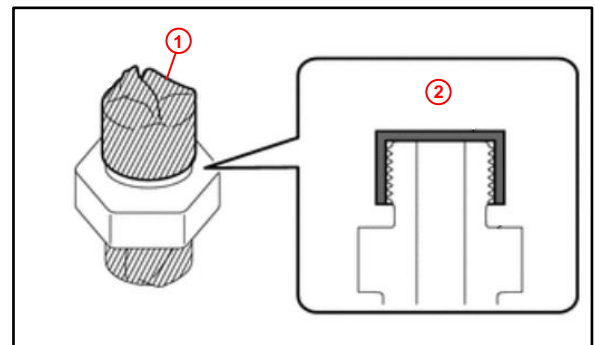

Figure 20.



1	Hydrogen Supply Regulator Union
2	Protective Tape

Mirai Hydrogen Supply Regulator Noise

Repair Procedure (Continued)

- (4) Coat a NEW O-ring (P/N 90301-11036) with Toyota Genuine FC Grease.
- (5) Install the O-ring to the hydrogen supply regulator union.

NOTICE

- Make sure not to damage the O-ring.
- Make sure the O-ring is NOT twisted.
- Make sure that the O-ring is NOT pinched.

Figure 21.

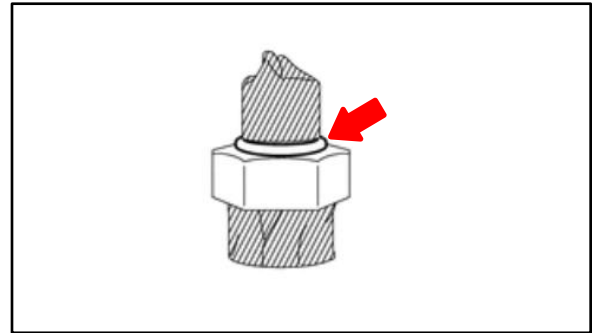

- (6) Remove the protective tape from the hydrogen supply regulator union.
- (7) Coat the O-ring and the threaded portion of the hydrogen supply regulator union with Toyota Genuine FC Grease.

NOTICE

To prevent the hydrogen supply regulator union installation portion from being contaminated by dust, metal fragments, etc., do NOT remove the protective tape from it until immediately BEFORE performing the work.

Figure 22.

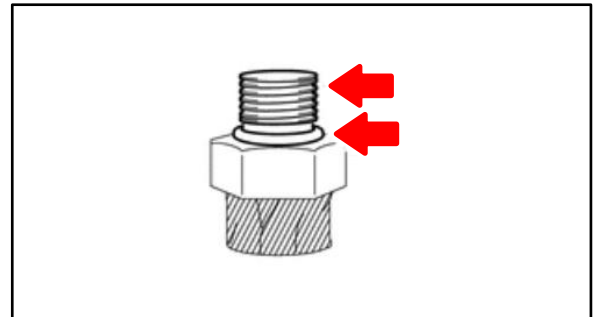

- (8) Install the hydrogen supply regulator union.
Torque: 41.5 N*m (423 kgf*cm, 31 ft*lbf)

NOTICE

To prevent damage to the seal portions and threaded portions, and to prevent foreign matter such as dust or metal fragments from entering the openings, do NOT remove the protective tape covering the seal portions, threaded portions, and openings of the hydrogen supply regulator union until immediately BEFORE performing work.

Mirai Hydrogen Supply Regulator Noise

Repair Procedure (Continued)

- I. Apply Toyota Genuine FC Grease to a NEW O-ring (P/N 90301-09037) and to the threaded portion of the hydrogen supply regulator union.

Figure 23.

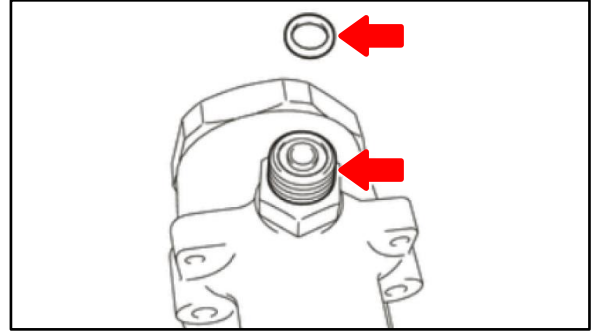

- J. Install the O-ring to the hydrogen supply regulator union.

NOTICE

During installation, make sure not to damage the O-ring.

- K. Install the No. 1 hydrogen supply regulator plug to the hydrogen supply regulator union.
Torque: 25 N*m (255 kgf*cm, 18 ft*lbf)

Figure 24.

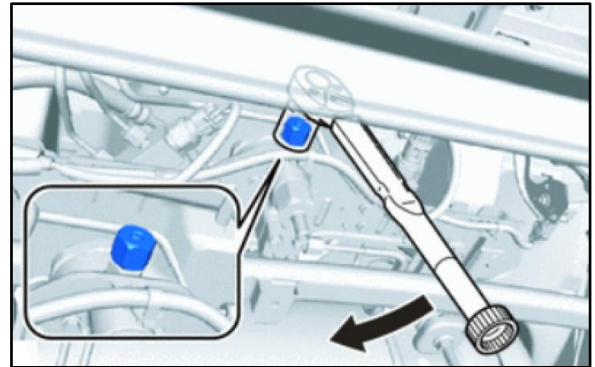

Mirai Hydrogen Supply Regulator Noise

Repair Procedure (Continued)

- L. Using an 8 mm socket hexagon wrench, rotate the adjustment bolt counterclockwise, and open the No. 1 hydrogen tank assembly manual valve.

CAUTION

BEFORE opening the manual valve, check that the hydrogen gas contained in the hydrogen piping has been depressurized.

NOTICE

- The manual valve shuts OFF the pressure from the hydrogen tank assembly, so be careful not to damage the hexagonal portion.
- If the hexagonal portion is damaged, it will be impossible to operate the adjustment bolt.
- Do NOT rotate the adjustment bolt more than four rotations.
- Rotating the adjustment bolt more than four rotations could damage the manual valve.
- If the manual valve is damaged, it will be necessary to replace the No. 1 hydrogen tank assembly.

HINT

When the manual valve is opened, the protrusion of the adjustment bolt is 3.5 mm (0.138 in.) or less.

Figure 25.

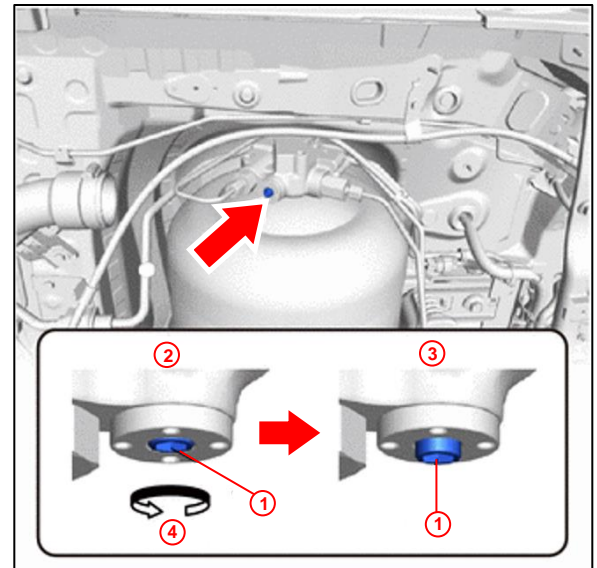

1	Adjustment Bolt
2	Manual Valve Closed
3	Manual Valve Open
4	Counterclockwise

Figure 26.

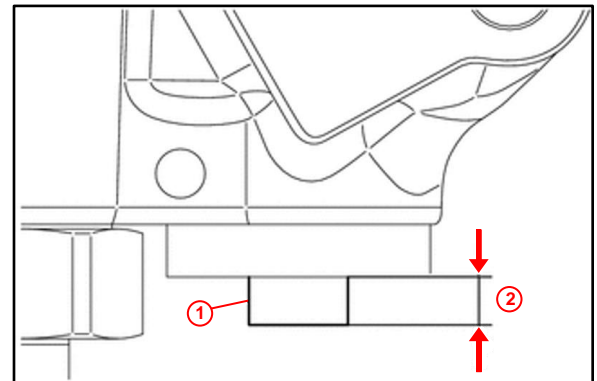

1	Adjustment Bolt
2	Protrusion

8. Connect the negative (-) terminal of the auxiliary battery.
Refer to TIS, applicable model and model year Repair Manual:
- 2016 – 2017 Mirai:
General – Maintenance – [“Maintenance: Auxiliary Battery: Installation”](#)

Mirai Hydrogen Supply Regulator Noise

Repair Procedure (Continued)

9. Ready ON the vehicle to confirm pressure in hydrogen lines BEFORE performing ANY inspections.

Inspection Procedure

- (1) Blow compressed air around the underside of the vehicle.

HINT

To enable accurate detection of hydrogen gas leaks from the piping, blow compressed air from the front of the vehicle toward the rear.

Figure 27.

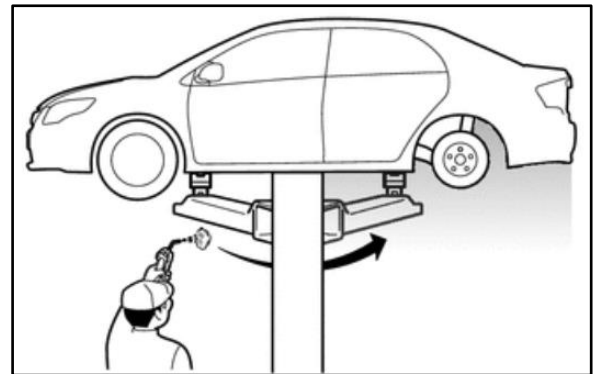

Mirai Hydrogen Supply Regulator Noise

Inspection Procedure (Continued)

- (2) Using the SST and a hydrogen gas detector, measure each of the measurement locations for approximately 10 continuous seconds per location.

SST: 09401-62010

HINT

- Hold the tip in light contact with the location so that the tip does not deform.
- Immediately AFTER the measurement starts, the measured value may be unstable.

NOTE

Measure the area near the boss or center of the hydrogen tank assembly at 300 ppm or less.

Figure 28. Hydrogen Gas Contact Location

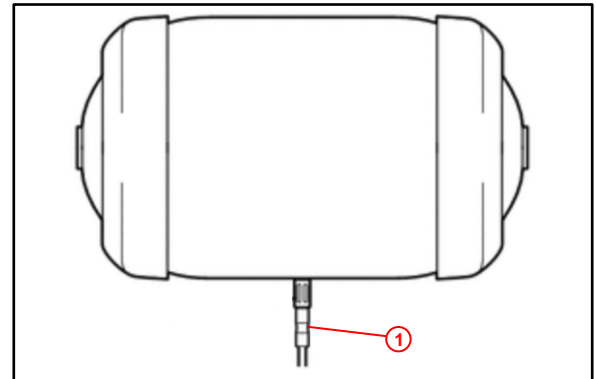

1	Hydrogen Gas Detector
---	-----------------------

Figure 29.

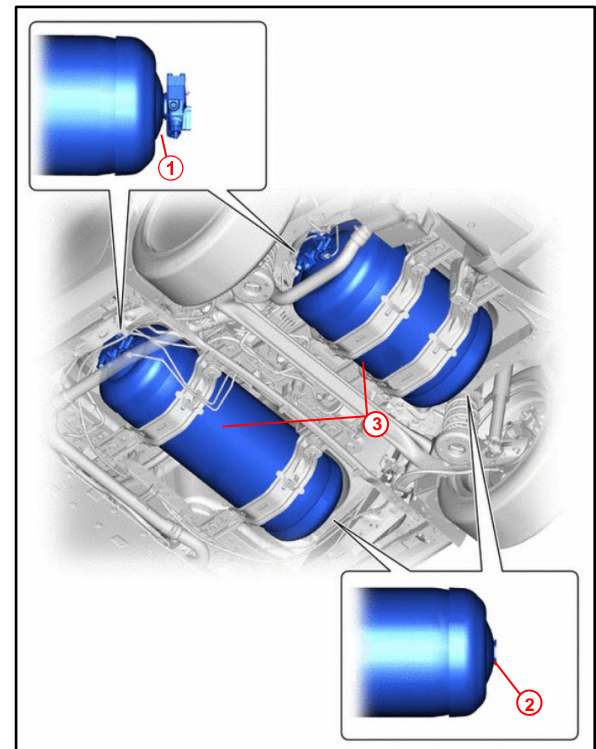

1	Boss Valve Side of Hydrogen Tank Assembly
2	Boss End Side of Hydrogen Tank Assembly
3	Center of Hydrogen Tank Assembly (one location in center of hydrogen tank assembly from underside of vehicle)

Mirai Hydrogen Supply Regulator Noise

Inspection Procedure (Continued)

- (3) Inspect for hydrogen gas leak.

NOTE

Perform the hydrogen gas leak inspection when the fuel remaining warning light is NOT illuminated.

- a. Remove the LH rear tire.
- b. Remove the LH rear bumper side seal.
- c. Peel back the LH rear wheel house liner.

1. Remove the three clips.

Figure 30.

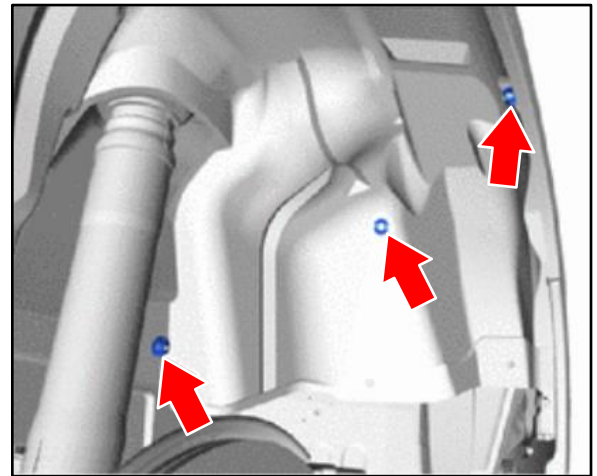

2. Peel back the LH rear wheel house liner as shown.

Figure 31.

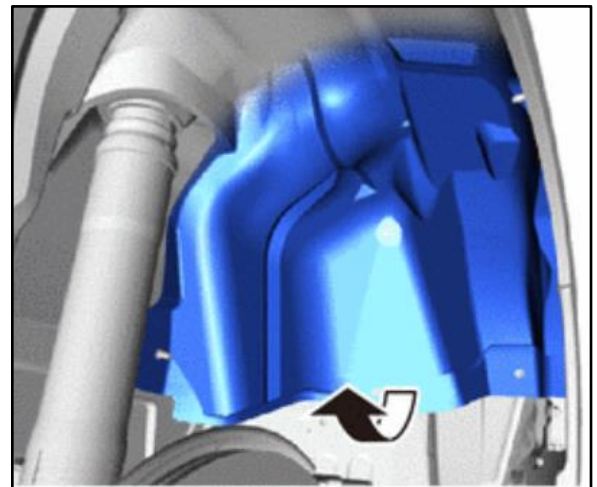

Mirai Hydrogen Supply Regulator Noise

Inspection Procedure (Continued)

HINT

- Immediately AFTER the measurement starts, the measured value may be unstable.
- Per the Repair Manual, if the specification is NOT met, replace the hydrogen tank assembly with a NEW one.

Figure 32.

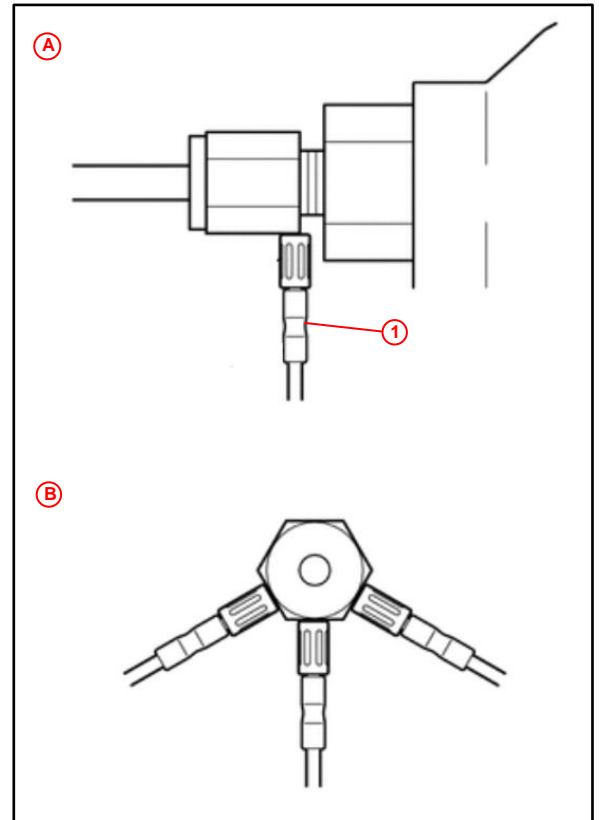

1	Hydrogen Gas Detector
A	Cutaway View
B	Side View

Mirai Hydrogen Supply Regulator Noise

Inspection Procedure (Continued)

NOTE

For items 1 – 13, measure the area near the piping, connecting portion, or sensor connecting portion at 300 ppm or less.

Figure 33.

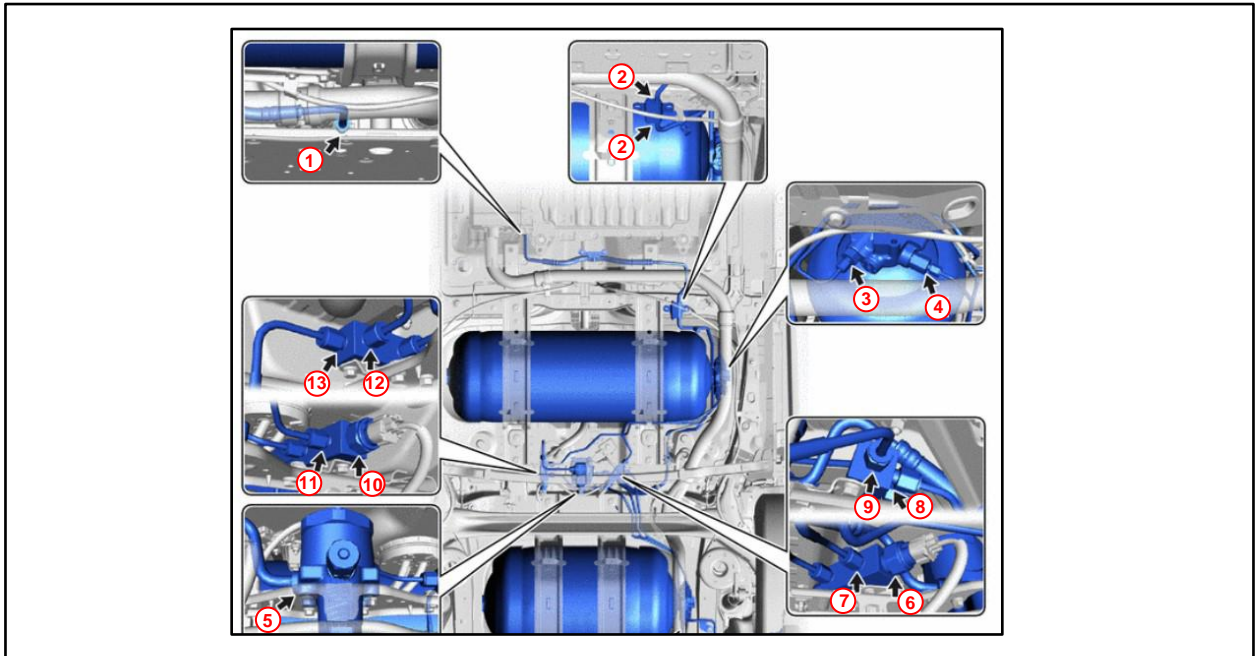

1	Connection Between FC Stack Assembly and No. 1 Hydrogen Supply Tube Sub-assembly
2	Connection Between No. 1 Hydrogen Supply Tube Sub-assembly and No. 2 Hydrogen Supply Tube Sub-assembly
3	Connection Between No. 1 Hydrogen Tank Assembly and No. 4 Hydrogen Tank Tube
4	Connection Between No. 1 Hydrogen Tank Assembly and No. 2 Hydrogen Tank Tube
5	Connection Between Hydrogen Supply Regulator Assembly and No. 2 Hydrogen Supply Tube Sub-assembly
6	Hydrogen Tank Tube Joint (for Inlet Side), Installation Location of Hydrogen Tank Pressure Sensor
7	Connection Between Hydrogen Tank Tube Joint (for Inlet Side) and No. 3 Hydrogen Tank Tube
8	Connection Between Hydrogen Tank Tube Joint (for Inlet Side) and Hydrogen Tank Tube Assembly
9	Connection Between Hydrogen Tank Tube Joint (for Inlet Side) and No. 2 Hydrogen Tank Tube
10	Hydrogen Tank Tube Joint (for Outlet Side), Installation Location of Hydrogen Tank Pressure Sensor
11	Connection Between Hydrogen Tank Tube Joint (for Outlet Side) and No. 5 Hydrogen Tank Tube
12	Connection Between Hydrogen Tank Tube Joint (for Outlet Side) and No. 4 Hydrogen Tank Tube
13	Connection Between Hydrogen Tank Tube Joint (for Outlet Side) and No. 6 Hydrogen Tank Tube

Mirai Hydrogen Supply Regulator Noise

Inspection Procedure (Continued)

NOTE

- For items 14 – 18, measure the area near the piping, connecting portion, or sensor connecting portion at 300 ppm or less.
- For item 19, measure with the tip of the hydrogen leak detector in direct contact with the filling port at 1,000 ppm or less.^{4, *5}

Figure 34.

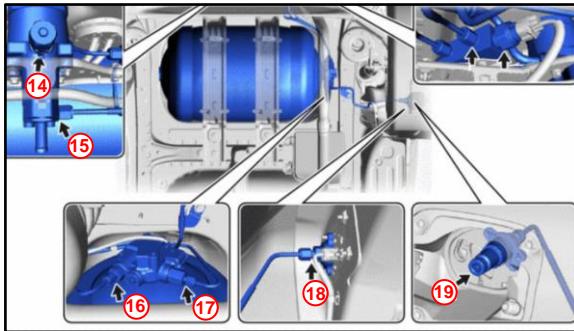

14	Medium Pressure Port of Hydrogen Supply Regulator Assembly¹
15	Connection Between Hydrogen Supply Regulator Assembly and No. 6 Hydrogen Tank Tube
16	Connection Between No. 2 Hydrogen Tank Assembly and No. 5 Hydrogen Tank Tube
17	Connection Between No. 2 Hydrogen Tank Assembly and No. 3 Hydrogen Tank Tube
18	Connection Between Hydrogen Inlet Receptacle Assembly and Hydrogen Tank Tube Assembly²
19	Filling Port of Hydrogen Inlet Receptacle Assembly³

Figure 35.

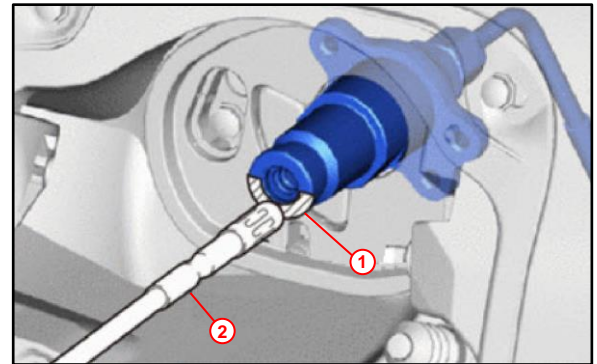

1	Contact Area for Hydrogen Leak Detector
2	Hydrogen Leak Detector

*1: If the value is NOT as specified, replace the O-ring of the medium pressure port.
 *2: Measure from underneath the vehicle, with the LH rear wheel house liner peeled back.
 *3: Because there is a possibility of erroneously detecting hydrogen that has accumulated near the filling port, open the hydrogen inlet receptacle cap and wait for AT LEAST 3 minutes before performing the measurement.
 *4: When performing leak inspection of the hydrogen inlet receptacle assembly, hold the tip of the hydrogen leak detector in light contact with the area shown in the illustration (Figure 35).
 *5: To prevent damage to the O-ring, do NOT insert the tip of the hydrogen leak detector into the filling port of the hydrogen inlet receptacle assembly.

Mirai Hydrogen Supply Regulator Noise

Inspection Procedure (Continued)

- (4) Install the LH rear wheel house liner.
- (5) Install the LH rear bumper side seal.
- (6) Install the LH rear tire.
- (7) Install the exhaust pipe and under vehicle covers.

Refer to TIS, applicable model and model year Repair Manual:

- 2016 – 2017 Mirai:
Engine/Hybrid System – Intake/Exhaust – [“Intake / Exhaust: Exhaust Pipe: Installation”](#)

Repair Procedure (Continued)

10. Test drive the vehicle to verify the repair.

Is the chirp noise still present?

- **YES** — Repeat steps 7 – 9 of the Repair Procedure up to a total of four times until the repair is complete.
- **NO** — The repair is complete.

NOTE

If the condition still exists after repeating steps 7 – 9 of the Repair Procedure, replace the hydrogen supply regulator.