

Front License Plate & Mounting Bracket Installation

Service Category General

Section Pre-Delivery Service

Market USA

Lexus Supports
ASE Certification 

Applicability

YEAR(S)	MODEL(S)	ADDITIONAL INFORMATION
2018	ES300H, ES350	

Introduction

The front license plate mounting bracket and 2 self-tapping screws for the 2018 model year ES 300h and ES 350 are stored in the luggage compartment. Install the license plate and mounting bracket during Pre-Delivery Service (PDS).

Warranty Information

OP CODE	DESCRIPTION	TIME	OFFP	T1	T2
N/A	Not Applicable to Warranty	–	–	–	–

Front License Plate & Mounting Bracket Installation

Repair Procedure

1. Align holes "A" of the front license plate mounting bracket with the dimples on the radiator grille.

HINT

- Holes "A" are used for installation of the front license plate mounting bracket to the radiator grille.
- Holes "B" are used for installation of the front license plate to the mounting bracket.

Figure 1.

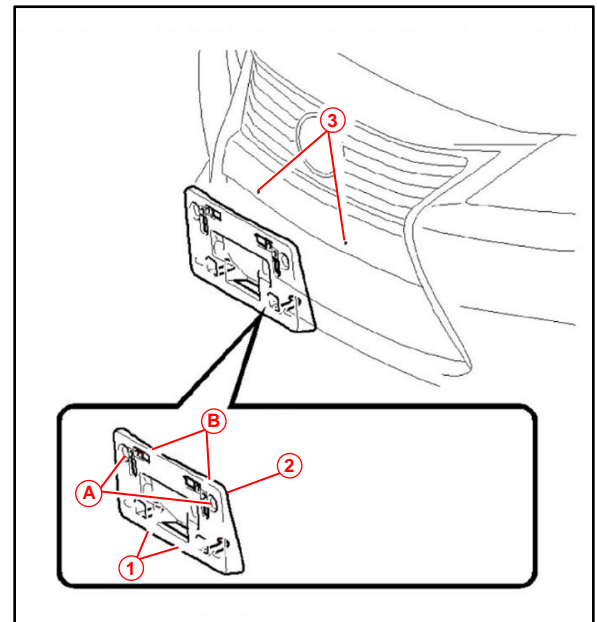

1	Hooks
2	Mounting Bracket
3	Dimples

2. Attach the hooks of the front license plate mounting bracket to the air intake of the radiator grille and hold in place.

Front License Plate & Mounting Bracket Installation

Repair Procedure (Continued)

3. Install the front license plate mounting bracket to the radiator grille using 2 self-tapping screws.

HINT

Tighten the passenger's side (round hole) self-tapping screw first, and then tighten the driver's side (slotted hole) self-tapping screw. Do NOT over-tighten the self-tapping screws.

Figure 2.

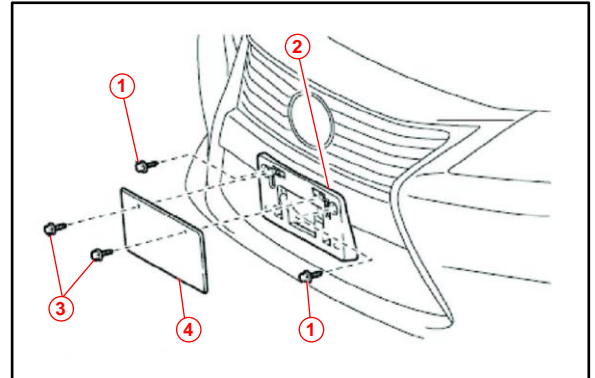

1	Self-tapping Screw
2	Mounting Bracket
3	Bolt
4	License Plate

4. Install the front license plate to the mounting bracket using 2 non-corroding bolts.

Nominal Length: 15.0 mm (0.59 in.)
Diameter: 6.0 mm (0.24 in.)

Figure 3.

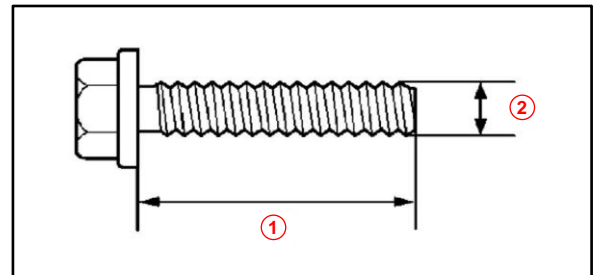

1	Nominal Length
2	Diameter