



**Countries:** CANADA, UNITED STATES, MEXICO  
**Availability:** ISIS, NotSIR  
**Major System:** COOLING  
**Current Language:** English  
**Other Languages:** NONE  
**Viewed:** 139

**Document ID:** IK0900123  
**Revision:** 1  
**Created:** 10/19/2017  
**Last Modified:** 10/26/2017  
**Author:** Jason Heckler

[Less Info](#)

Hide Details

Coding Information

<b>Copy Link</b> 	<b>Copy Relative Link</b> 	<b>Bookmark</b>  <a href="#">View My Bookmarks</a>	<b>Add to Favorites</b> 	<b>Print</b> 	<b>Provide Feedback</b> 	<b>Helpful</b>  4	<b>Not Helpful</b>  0
----------------------	-------------------------------	--	-----------------------------	------------------	-----------------------------	-------------------------	-----------------------------

**Title:** Fan hub bracket bolts loose or missing

**Applies To:** LT, HX, Prostar, Lonestar, with 12THT, 12TKY fan drives

## CHANGE LOG

Please refer to the change log text box below for recent changes to this article:

10/26/2017 - Initial Article Release

## DESCRIPTION

This document will guide the user through identifying and correcting fan hub mounting bracket issue.

## SYMPTOM(s)

DTC/Light	Description
N/A	N/A

### **Customer Observations or Concerns:**

Fan hub mounting bracket loose or missing bolts. Possible damage to the fan or fan hub.

## SPECIAL TOOL(s) / SOFTWARE

[Tools Resource Center](#)

## SERVICE PARTS INFORMATION

Kit Description	Part Number	Quantity Required	Notes
Fan	Per VIN	1 if needed	

Fan Drive	Per VIN	1 if needed	
Washers	30185R1	4	
Bolts	30748R1	4	

**DIAGNOSTIC and REPAIR STEP(s)**

Step	Action	Decision
1	<b>DIAGNOSTIC:</b> Has an issue been identified with the fan hub bracket/bolts?	Yes. Go to Step 2
		No. Article does not Apply

Step	Action	Decision
2	<b>DIAGNOSTIC:</b> Is there damage to the fan hub and/or fan?	Yes. Obtain new fan hub and/or fan. Go to Step 3.
		No. Go to Step 3.

Step	Action	Decision
3	Using a disc grinder, remove the paint from the fan hub bracket holes, to ensure proper contact for washer and bolts. See Figure 1 to identify areas that must be free of paint.	Go to Step 4.

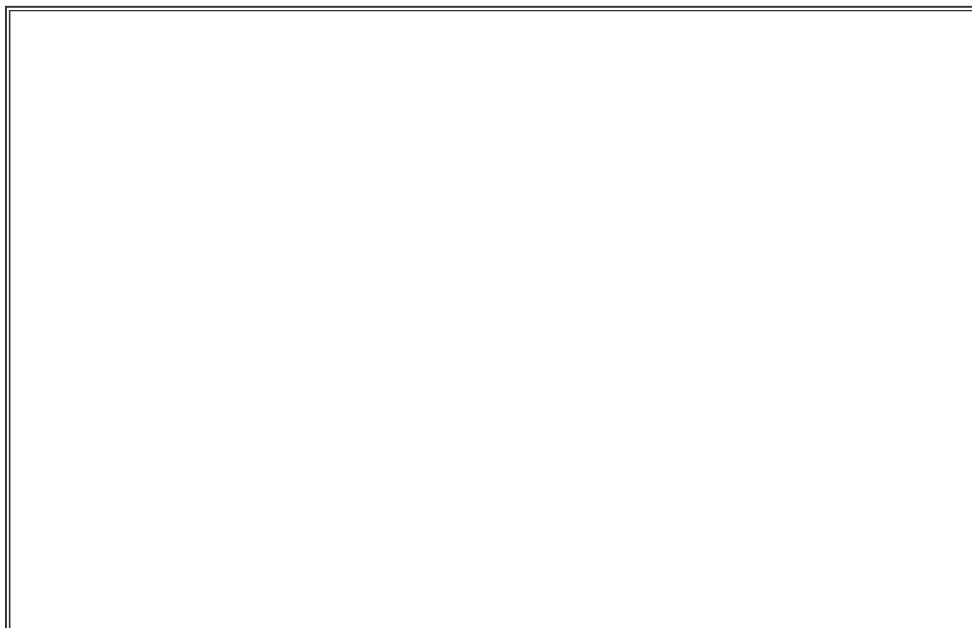

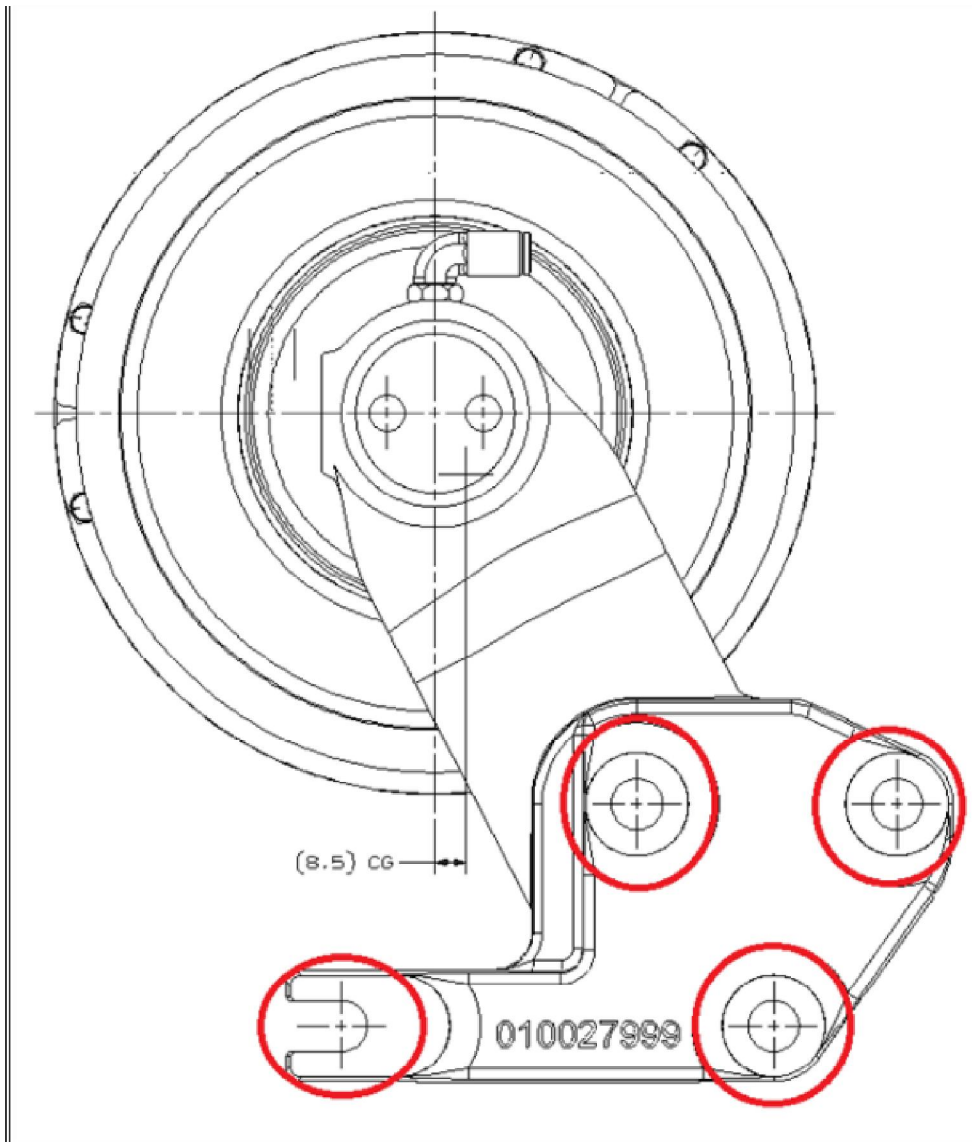
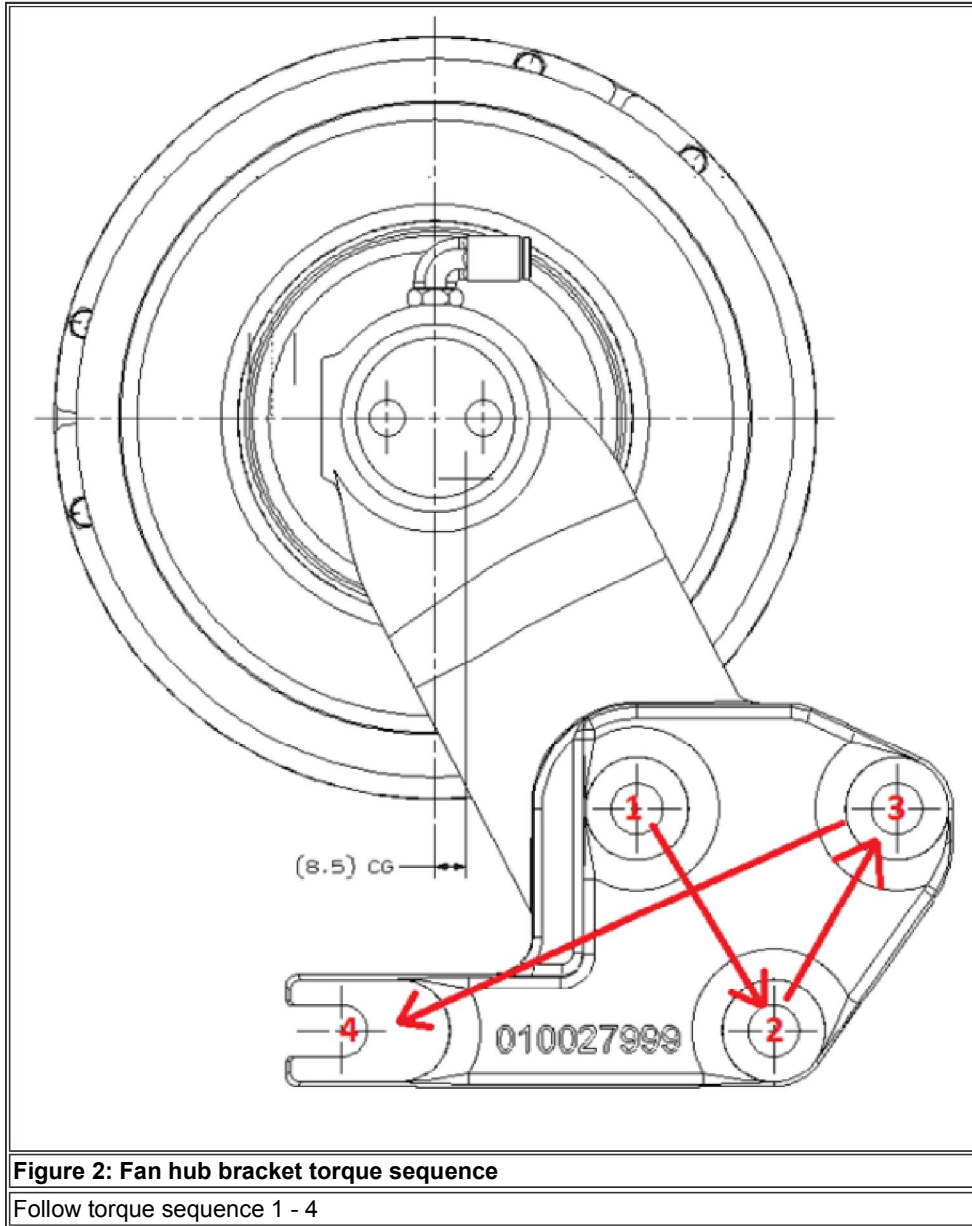

**Figure 1: Fan Hub Bracket**

Red identifies areas that need to be paint free.

Step	Action	Decision
4	Replace damaged components and install oversize bolts and washers.	Go to Step 5.

Step	Action	Decision
5	<p><b>DIAGNOSTIC:</b></p> <p>Torque bolts 95 to 105 ft lbs (129-142Nm) following the torque sequence in Figure 2</p>	End of Repair



## **REPAIR STEP(s)**

## **WARRANTY INFORMATION**

### **Warranty Claim Coding:**

Refer to the [Warranty Coding Manual](#) for Group and Noun Codes.

### **Standard Repair Time(s):**

Refer to the [SRT Manual](#) for Repair Times

## **OTHER RESOURCES**

[Master Service Information Site](#)

 Hide Details

Feedback Information

Viewed: 138  
Helpful: 4  
Not Helpful: 0

No Feedback Found