

Customer Satisfaction Program

16038 Transmission Oil Cooler Line in Contact with Body Stud



Reference Number: N162051960

Release Date: January 2017
Revision: 00

Attention: This program is in effect until February 28, 2019.

Make	Model	Model Year		RPO	Description
		From	To		
Chevrolet	Corvette	2016	2016	M5U	Transmission-Auto 8 Speed
				V03	Cooling System-Extra Capacity

Involved vehicles are marked "open" on the Investigate Vehicle History screen in GM Global Warranty Management system. This site should always be checked to confirm vehicle involvement prior to beginning any required inspections and/or repairs.

Condition	Certain 2016 model year Chevrolet Corvette vehicles, equipped with an 8 speed automatic transmission (RPO M5U) and an extra capacity cooling system (RPO V03), may have a condition in which the transmission oil cooler (TOC) lines come in contact with the body studs for the outer quarter panel reinforcement. Over time this contact may wear a hole through the line causing a fluid leak. It is possible that the leak may not be visible, but could lead to illumination of the malfunction indicator lamp, rough/irregular shifts, slipping, and, eventually, complete loss of propulsion.
Correction	Install a protective sleeve to the TOC line.

Parts

Quantity	Part Name	Part No.
1	Transmission Fluid Auxiliary Cooler Inlet Rear Intermediate Pipe Sleeve Strap	*11509086
1	Transmission Fluid Auxiliary Cooler Inlet Rear Intermediate Pipe Sleeve	84281801

* Sold in a package quantity of 10.

Due to the small number (60) of vehicles involved, dealers are encouraged not to order program parts for use as shelf stock. Parts may have quantity limiters in effect.

Warranty Information

Labor Operation	Description	Labor Time	Trans. Type	Net Item
9102877	Install Protective Sleeve on Transmission Oil Cooler Line	0.6	ZFAT	N/A

Service Procedure

1. Raise and support the vehicle. Refer to *Lifting and Jacking the Vehicle* in SI.
2. Remove the driver side rear wheelhouse liner. Refer to *Rear Wheelhouse Liner Replacement* in SI.

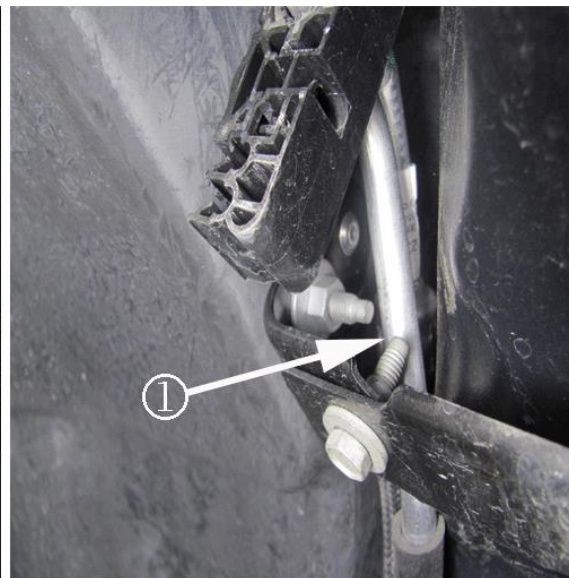
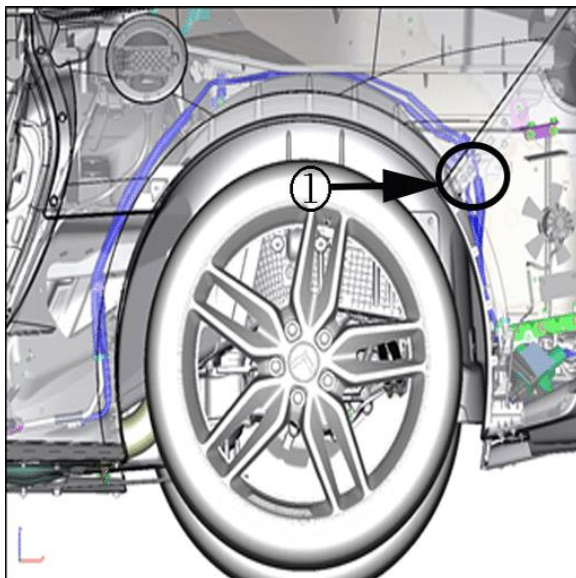

4673806

3. Locate the area of the transmission fluid auxiliary cooler inlet rear intermediate pipe that is being serviced (1).

Customer Satisfaction Program

16038 Transmission Oil Cooler Line in Contact with Body Stud

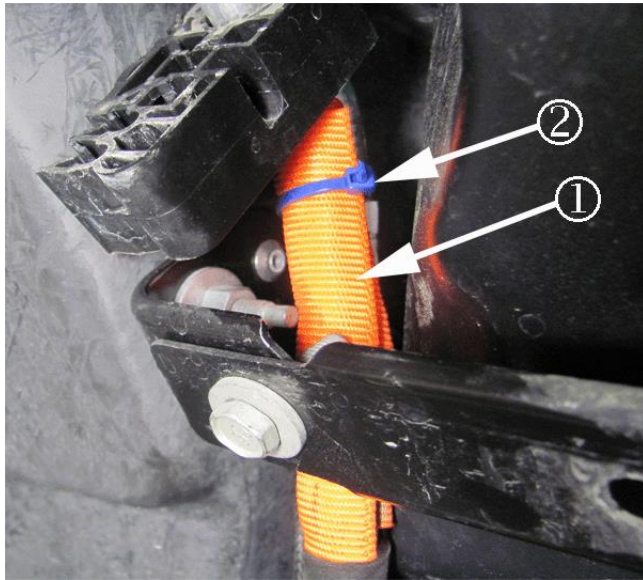

4673809

Caution: Ensure the protective sleeve is orientated so the opening in the sleeve is away from the body bolt.

Note: The tie strap and protective sleeve will be different colors than what is shown. The sleeve and tie strap shown in this picture are for illustrative purposes only.

4. Install the protective sleeve (1) onto the transmission fluid auxiliary cooler inlet rear intermediate pipe.
5. Install the tie strap (2) around the protective sleeve and cinch the tie strap.
6. Cut the excess off of the tie strap.
7. Install the driver side rear wheelhouse liner. Refer to *Rear Wheelhouse Liner Replacement* in SI.
8. Lower the vehicle. Refer to *Lifting and Jacking the Vehicle* in SI.

Dealer Responsibility

All new, used, GM Certified Used, courtesy transportation vehicles, dealer shuttle vehicles, etc. in dealers' possession and subject to this program must be held and inspected/repared per the service procedure of this bulletin before customers take possession of these vehicles. Involved vehicles must be held and not delivered to customers, dealer-traded, released to auction, used for demonstration, or any other purpose.

All GM Certified Used vehicles currently in the dealers' inventory within the Certified Pre-Owned Inventory System (CPOIS) will be de-certified and must be held and remedied per the service procedure in this bulletin. Upon submitting an accepted/paid warranty transaction in the Global Warranty Management (GWM) system, the vehicle can be re-certified for sale within the CPOIS system, or once again be used in the CTP program.

Dealers are to service all vehicles subject to this program at no charge to customers, regardless of mileage, age of vehicle, or ownership, through February 28, 2019. Customers who have recently purchased vehicles sold from your vehicle inventory, and for which there is no customer information indicated on the involved vehicle listing, are to be contacted by the dealer. Arrangements are to be made to make the required correction according to the instructions contained in this bulletin. A copy of the customer letter is provided in this bulletin for your use in contacting customers. Program follow-up cards should not be used for this purpose, since the customer may not as yet have received the notification letter.

In summary, whenever a vehicle subject to this program enters your vehicle inventory, or is in your facility for service through February 28, 2019, you must take the steps necessary to be sure the program correction has been made before selling or releasing the vehicle.

Customer Satisfaction Program

16038 Transmission Oil Cooler Line in Contact with Body Stud



Dealer Reports

For dealers with involved vehicles, a listing with involved vehicles has been prepared and will be provided to U.S. dealers through the GM GlobalConnect Recall Reports, or sent directly to export dealers. The listing may contain customer names and addresses obtained from Motor Vehicle Registration Records. The use of such motor vehicle registration data for any purpose other than follow-up necessary to complete this program is a violation of law in several states/provinces/countries. Accordingly, you are urged to limit the use of this report to the follow-up necessary to complete this program.

Courtesy Transportation – For USA

Courtesy transportation is available for customers whose vehicles are involved in a product program and still within the warranty coverage period. See General Motors Service Policies and Procedures Manual, Sections 1.4 and 6.1.10, for courtesy transportation program details.

Customer Notification

USA - General Motors will notify customers of this program on their vehicle (see copy of customer letter included with this bulletin).

Export - Letters will be sent to known owners of record located within areas covered by the US National Traffic and Motor Vehicle Safety Act. For owners outside these areas, dealers should notify customers using the attached sample letter.

GM bulletins are intended for use by professional technicians, NOT a "do-it-yourselfer". They are written to inform these technicians of conditions that may occur on some vehicles, or to provide information that could assist in the proper service of a vehicle. Properly trained technicians have the tools, equipment, safety instructions, and know-how to do a job properly and safely. If a condition is described, DO NOT assume that the bulletin applies to your vehicle, or that your vehicle will have that condition. See your dealer for information on whether your vehicle may benefit from the information.



**We Support
Voluntary Technician
Certification**

Customer Satisfaction Program

16038 Transmission Oil Cooler Line in Contact with Body Stud



February 2017

This notice applies to your vehicle, **VIN:** _____

Dear General Motors Customer:

We have learned that your 2016 model year Chevrolet Corvette may have a condition in which the transmission oil cooler lines come in contact with the body studs for the outer quarter panel reinforcement. Over time this contact may wear a hole through the line causing a fluid leak. It is possible that the leak may not be visible, but could lead to illumination of the malfunction indicator lamp, rough/irregular shifts, slipping, and, eventually, complete loss of propulsion.

Your satisfaction with your Corvette is very important to us, so we are announcing a program to prevent this condition.

What We Will Do: Your GM dealer will install a protective sleeve to the transmission oil cooler line. This service will be performed for you at **no charge until February 28, 2019**. After that, any applicable warranty will apply.

What You Should Do: To limit any possible inconvenience, we recommend that you contact your dealer as soon as possible to schedule an appointment for this repair. By scheduling an appointment, your dealer can ensure that the necessary parts will be available on your scheduled appointment date.

If you have any questions or concerns that your dealer is unable to resolve, please contact the appropriate Customer Assistance Center at the number listed below.

Division	Number	Text Telephones (TTY)
Chevrolet	1-800-222-1020	1-800-833-2438
Puerto Rico – English	1-800-496-9992	
Puerto Rico – Español	1-800-496-9993	
Virgin Islands	1-800-496-9994	

We sincerely regret any inconvenience or concern that this situation may cause you. We want you to know that we will do our best, throughout your ownership experience, to ensure that your Corvette provides you many miles of enjoyable driving.

Terry M. Inch
Executive Director
Global Connected Customer Experience

16038

GLOBAL SAFETY FIELD INVESTIGATIONS
DCS4316
URGENT - DISTRIBUTE IMMEDIATELY

Date: January 20, 2017

Subject: 16038 - Customer Satisfaction Program
Transmission Oil Cooler Line in Contact with Body Stud

Models: 2016 Chevrolet Corvette
Equipped with 8-speed Automatic Transmission (RPO M5U) and Extra
Capacity Cooling System (RPO V03)

To: All General Motors Dealers

General Motors is releasing Customer Satisfaction Program 16038 today. The total number of U.S. vehicles involved is approximately 55. Please see the attached bulletin for details.

Customer Letter Mailing

The customer letter mailing will begin on February 3, 2017.

Global Warranty Management (GWM)

The Investigate Vehicle History (IVH) screen in the GWM system will be updated January 21, 2017. A list of involved vehicles in dealer new inventory is attached to this message. Please hold all warranty transactions until the VIN appears in IVH.

END OF MESSAGE

GLOBAL SAFETY FIELD INVESTIGATIONS