



Countries:	AUSTRALIA, CANADA, TAIWAN, UNITED STATES, MEXICO, PUERTO RICO, GUAM, KOREA, SOUTH KOREA, NEW ZEALAND	Document ID:	IK1201102
Availability:	ISIS, NotSIR	Revision:	3
Major System:	ENGINES	Created:	3/17/2014
Current Language:	English	Last Modified:	1/11/2017
Other Languages:	NONE	Author:	Keith Kierzek
Viewed:	2141		

[Less Info](#)

Hide Details

Coding Information

Copy Link 	Copy Relative Link 	Bookmark View My Bookmarks	Add to Favorites 	Print 	Provide Feedback 	Helpful 13	Not Helpful 1
----------------------	-------------------------------	--	-----------------------------	------------------	-----------------------------	--------------------------	-----------------------------

Title: ISX Low Coolant Switch Diagnostics

Applies To: Prostar Units with Cummins ISX

Change Log

Dealers: Please refer to the change log text box below for recent changes to this article:

11/11/2017- Edited article for feedback purposes. 5/9/2016- Changed step 2 to check resistance with key off. 07/09/2014 - Updated layout, added Group and Noun in Warranty Information 04/21/2014 - Article Created
--

Description

- Units may set active faults for coolant level, even though the coolant level checks out ok.

Normal Operation

- The coolant level sensor is a switch, and is used to measure the level of the engine coolant in the radiator top tank (surge tank). The coolant level sensor is immersed in the coolant and returns a different signal voltage when immersed in coolant versus being out of coolant. The engine control module (ECM) monitors the change in the signal voltage to determine the level of the engine coolant.
- The purpose of the coolant level module is to minimize galvanic corrosion by reducing the amount of electrical flow through the coolant level sensor.
- The ECM continuously runs diagnostics on this circuit when the key switch is in the ON position or when the engine is running.
- Part of the ECM logic supports a slosh timer which allows for some period of time when the coolant in the surge tank is not level with respect to ground due to centrifugal forces while negotiating cloverleaf type ramps, short steep ascents and descents or during braking and acceleration. In order for the perceived coolant level to change states, the coolant level shall remain in the new state for 30 consecutive seconds.

Symptom(s)

Diagnostic Trouble Code(s) & Dashboard Indicator Light(s):

Cummins Fault Code	SPN	FMI	Description	Warning Lamp	Expected Voltage at ECM J2 pin 35 (Input)
195	111	3	Coolant level voltage above normal or shorted to high source	Amber Engine Warning Light	> 4.5 volts

196	111	4	Coolant level voltage below normal or shorted to low source	Amber Engine Warning Light	< 0.5 volts
197	111	1	Coolant level data valid but below normal operating range - Most severe level	Red Stop Engine Light	2.0 - 4.25 volts

Diagnostic Step(s)

- Inspect terminals and connectors at the probe, module, and ECM.
- Verify the terminals are locked in the connectors, the wiring is tight to the connector, and the terminals do not appear to be spread.

[LoneStar[®], ProStar[®] + and ProStar[®] + with Cummins[®] ISX15 Engine](#)

- Safely lower the level of the coolant surge tank so you can remove the sensor without spilling coolant.

Step	Test Point	Spec	Decision
Key ON, Coolant Probe PLUGGED IN, Coolant Module UNPLUGGED			
1	Connector 1378 (A to Gnd) Note: This VREF circuit is used by multiple components. Refer to the proper wiring schematic book	5v ± 0.5v	Yes: Go to Step 2 No: Repair wiring and retest
Key OFF, Coolant Probe PLUGGED IN, Coolant Module UNPLUGGED			
2	Connector 1378 (D to Gnd) Note: This GND circuit is used by multiple components. Refer to the proper wiring schematic book	< 5 Ω	Yes: Go to Step 3 No: Repair wiring and retest
Key ON, Coolant Probe UNPLUGGED, Coolant Module PLUGGED IN			
3	Connector 6401 (A to Gnd)	< 0.25v	Yes: Go to Step 4 No: Replace Coolant Module
4	Connector 6401 (B to Gnd)	< 0.25v	Yes: Go to Step 5 No: Replace Coolant Module
Key OFF, Coolant Probe UNPLUGGED, Coolant Module UNPLUGGED			
5	Connector 6401 (A to Gnd)	> 1000 Ω	Yes: Go to Step 6 No: Repair wiring and retest
6	Connector 6401 (B to Gnd)	> 1000 Ω	Yes: Go to Step 7 No: Repair wiring and retest
Remove Coolant Probe from Surge Tank (Terminal A is the (+) and wire K34 should be wired to it, Terminal B is the (-) and wire K34A should be wired to it)			
7	Measure Coolant Probe resistance from Terminal A to Probe Tip	68K Ω (±5%) (64600 Ω - 71400 Ω)	Yes: Go to Step 8 No: Replace Coolant Probe
8	Measure Coolant Probe resistance from Terminal A to Terminal B	210K Ω (±5%) (199500 Ω - 220500 Ω)	Yes: Go to Step 9 No: Replace Coolant Probe
9	Load test wiring following the outlined wiring schematic . If any wires do not carry an amp load properly they will need to be replaced using new terminals. If no trouble is found, and troubleshooting is completed, open a Technical Service case file for further assistance.		

Component Location

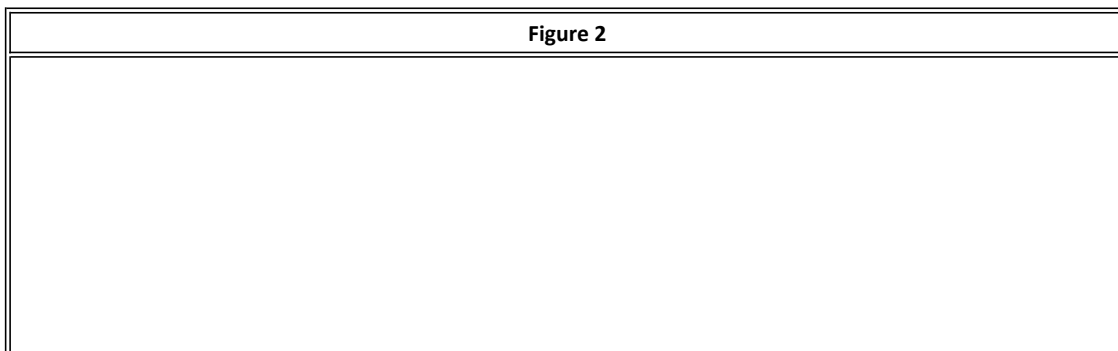
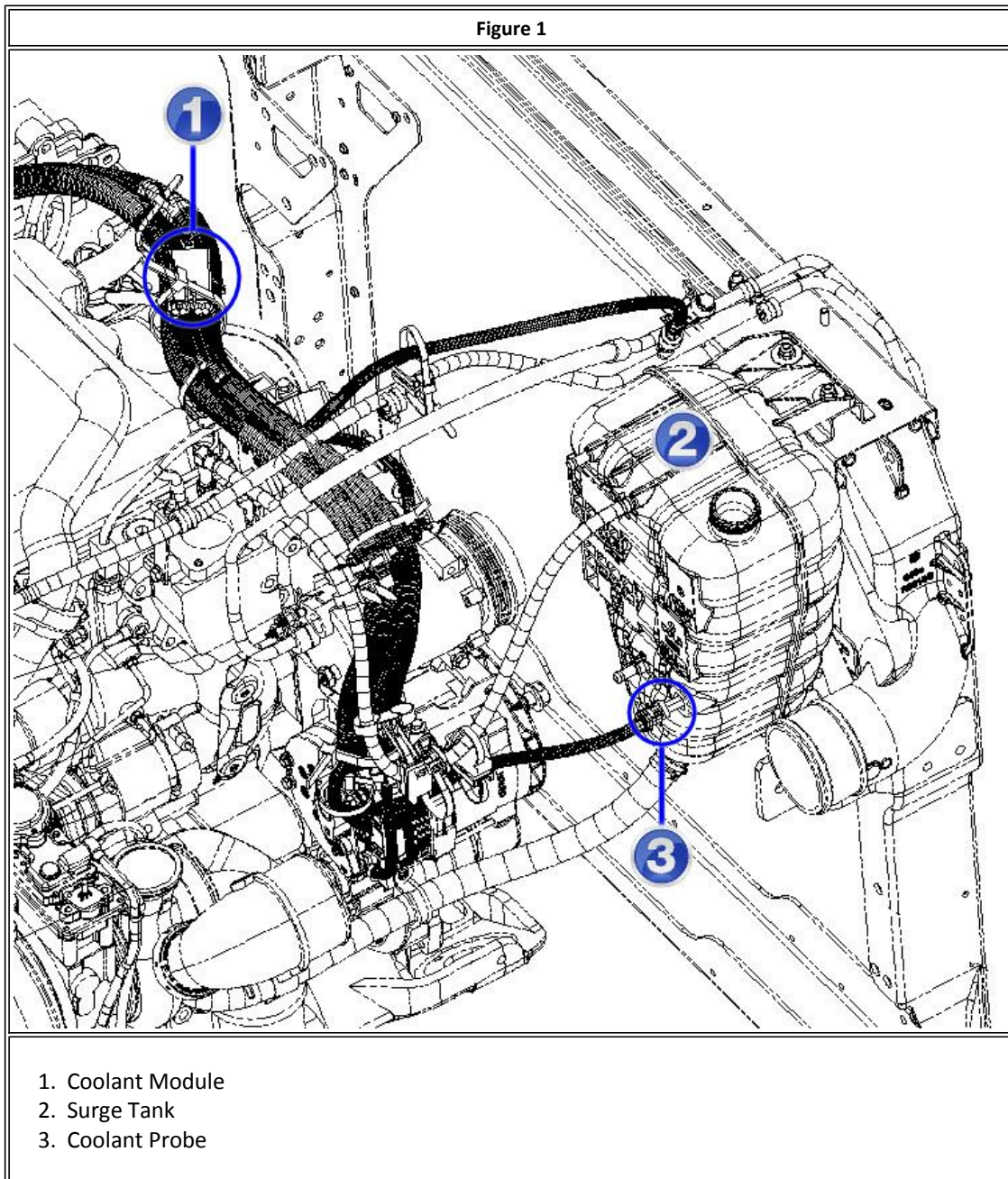

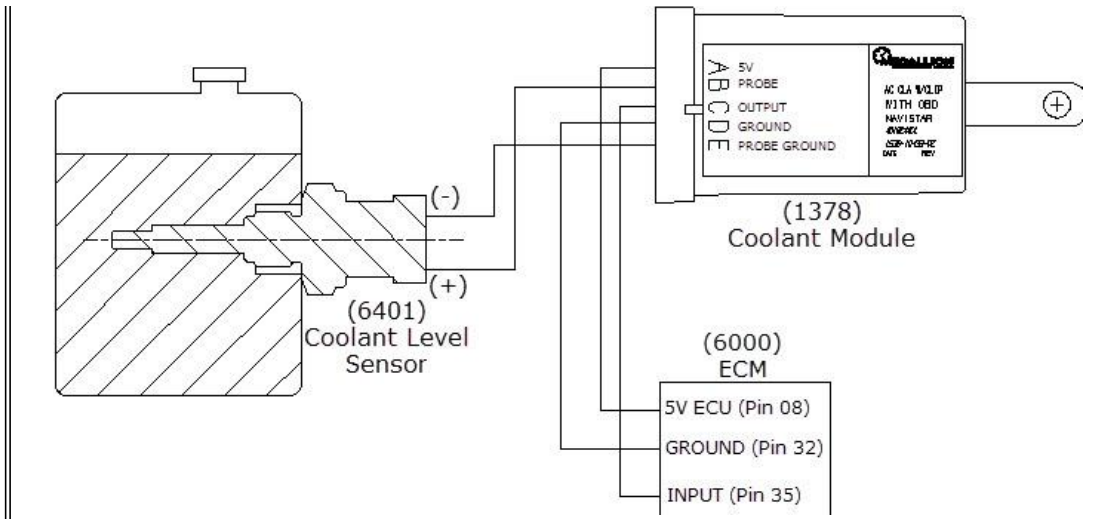

- Wiring Schematic

Figure 3

ECM CONNEXTOR
(6000)
CONNECTOR BODY LOCK
3743662C1
CONNECTOR 3945694C1

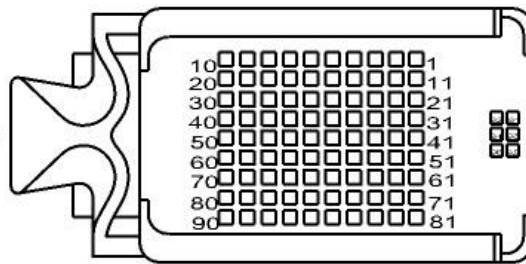

CAV	CIR	GAUGE	COLOR	TERMINAL
32	KA9A	20	TN	3743668C1
33	K97B	20	PL	3743668C1
34	PLUG	-	-	3744547C1
35	KA34E	20	TN	3743668C1
36	PLUG	-	-	3744547C1

COOLANT LEVEL SENSOR
(6401)

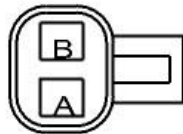

CONNECTOR 1671610C1

CAV	CIRCUIT	GAUGE	COLOR	TERMINAL	SEAL/SLEEVE
A#	K34	16	TN	2033819C1	1652325C1
B#	K34A	16	TN	2033819C1	1652325C1

**COOLANT MODULE
(1378)**

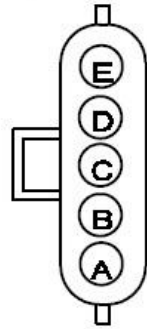

**CONNECTOR 1687789C1
BODY LOCK 1681378C1**

CAVITY	CIRCUIT	GAUGE	COLOR	TERMINAL	SEAL/SLEEVE
A	K6B	20	VT	2033819C1	1652325C1
B	K34	18	TN	2033819C1	1652325C1
C	K34E	20	TN	2033819C1	1652325C1
D	K34B	16	TN	2033819C1	1652325C1
E	K34A	18	TN	2033819C1	1652325C1

- Connector Composites

Service Part(s) Information

Kit Description	Part Number	Quantity Required	Ordering Instructions
Coolant Module	4019244C1	1	Order from Navistar
Surge Tank	2510603C92	1	Order from Navistar
Coolant Probe	4019236C2	1	Order from Navistar

Repair Step(s)



WARNING:

To avoid property damage, personal injury, or death, park the vehicle on a flat level surface, set the parking brake, turn the engine off, and chock the wheels.





WARNING:

To avoid personal injury or death from hot coolant or steam, allow the vehicle to cool. Wrap a thick heavy cloth around the radiator cap, push down and loosen the cap to the first notch and allow pressure to release through the overflow tube.

CAUTION:

Proper torque of the coolant probe is essential. If you over - torque the probe, you will create a crack in the surge tank and the tank will need to be replaced. Inspect surge tank adapter for signs of stress marks or thread damage from over torque conditions.

Figure 4	Figure 5	Figure 6
		
<p>Damaged threads on sensor port</p>	<p>Stress mark on knit line / meld line</p>	<p>Stress mark on knit line / meld line after removing coolant probe Note: The stress mark will be harder to see when the probe is removed</p>

Coolant probe torque spec:

- 12 - 15 Nm (9 - 11 lb/ft)

Warranty Information

Group	Noun
08846 - Warning Lights and Signals	269 - Module, Coolant Probe
	270 - Probe, Coolant Level

SRT Description	SRT Code Link		SRT (hr)
ECM Diagnostics	A12-2053A	(All Models)	0.9
Coolant Module, R/R	R09-8427S	(ProStar)	0.6
	S09-8427S	(LoneStar)	
Coolant Probe, R/R	R09-8427S-20	(ProStar)	0.6
	S09-8427S-20	(LoneStar)	

[Hide Details](#) Feedback Information

Viewed: 2140
Helpful: 13
Not Helpful: 1

Staff ID	Client ID	Comments	Created Date
	DY22084	You received the following feedback From: dy22084 - Andrew Mortimer Email Address: amortimer@nwcgroup.com Job Classification: SE008, Service Technician Dealer: RWC GROUP Feedback: VIN AN217857 with ISX has coolant module with only 4 wires and none of the wiring appears to follow this diag flow. is there a year cutoff that needs added to this diag flow?	1/27/2017 11:30:59 AM