



Countries: AUSTRALIA, BAHAMAS, BOLIVIA, BRAZIL, BELIZE, CANADA, CHILE, TAIWAN, COLOMBIA, COSTA RICA, DOMINICAN REPUBLIC, ECUADOR, EL SALVADOR, TRINIDAD AND TOBAGO, UNITED STATES, URUGUAY, VENEZUELA, MEXICO, ARUBA, NICARAGUA, PERU, PUERTO RICO, Curaçao, GUAM, GUATEMALA, GUYANA, HAITI, HONDURAS, JAMAICA, KOREA, SOUTH KOREA, NEW ZEALAND, PANAMA, SOUTH AFRICA

Document ID: IK0800080

Availability: ISIS, Bus ISIS, FleetISIS, Body Builder, IsSIR

Major System: ELECTRICAL SYSTEM

Current Language: English

Other Languages: [Portuguese](#), [Français](#), [Español](#)

Viewed: 103299

Revision: 23

Created: 8/22/2007

Last Modified: 1/12/2017

Author: Charles Schroeder

[Less Info](#)

Hide Details

Coding Information

Copy Link 	Copy Relative Link 	Bookmark View My Bookmarks	Add to Favorites 	Print 	Provide Feedback 	Helpful 10712	Not Helpful 7041
----------------------	-------------------------------	--	-----------------------------	------------------	-----------------------------	-----------------------------	--------------------------------

Title: J1939 Data Link Troubleshooting

Applies To: All Models with 250k Baud Data Link (Black 9-Pin Diagnostic Connector); Overview information for 500k Baud Data Link

Change Log

Dealers: Please refer to the change log text box below for recent changes to this article:

01/12/2017 - Added French and Spanish translations.

01/04/2017 - Added new sections for 500k Baud Vehicle Architecture: Phase 1 and Phase 2

11/17/2016 - Updated Step 19 based on dealer feedback.

10/04/2016 - Noted the troubleshooting cards in the article are the most current that are published. Noted when inspecting splice welds, visual inspection is destructive and the splice should be replaced using proper wire repair techniques.

05/12/2016 - Added information to "Service Information (Known Issues) for Service Tool loss of communication fault codes. The Ez-Tech or PocketMaxx

NOTE:

- This article is for general J1939 troubleshooting on 250k baud data link vehicles. They will have a black 9-pin diagnostic connector. The information provided applies to all models. Check the Fault Code Action Plan for the faults you are diagnosing, there may be model specific FCAP diagnostic information available.
- You **MUST** review the "Service Information (Known Issues)" section of this iKNOW article **PRIOR** to troubleshooting anything on the truck.

[Click Here for a printable PDF version of this article.](#)

Table of Contents

Description	Service Part(s) Information	500k Baud (Phase 1) Vehicle Architecture
Symptom(s)	Additional Resources	500k Baud (Phase 2) Vehicle Architecture
Special Tool(s) or Software	Connector Views	
Diagnostic Steps	Service Information (Known Issues)	

Description

There are a few things that you need to understand before troubleshooting the 1939 data link.

1. First, the drivetrain J1939 data link, J1939 body builder data link, and J1939 engine data link are three completely separate data links.
 - For specific examples of modules on each different data link [Click Here](#)
2. The different J1939 data links work the same way, but the wiring for them is not connected.

3. The troubleshooting below is geared towards the drive train J1939 data link, but the same principles apply to the body builder and engine data link.
4. The J1939 data link consists of a twisted pair of yellow and green wires that all the modules on the truck use to communicate with each other.
5. Two 120 ohm terminating resistors are wired in parallel on the data link. Total resistance on a properly working data link is 60 ohms.
6. When you are checking the data link, if the problem is not present, the data link will show good.
7. The J1939 data link may be referred to as data bus, or CAN as well.
8. A module is capable of being connected to the public and private data link, but the information remains separate.
 - Example: The Body Controller communicates on the public drivetrain data link, but also has the private body builder data link wired to it.
 - Example: The EIM communicates on the drivetrain data link, but also communicates with the ECM and ACM on the engine private data link.

NOTE:

The MaxxForce 7 TMV (Thermal Management Valve) is on the Public data link. This module will not show up on the sniffer. The ECM Engine and Chassis connector's data link terminals are connected internally to the module. E13 and C53 are internally connected. E14 and C54 are internally connected.

For Post-2007 vehicle 1939 troubleshooting, click on the appropriate link below:

- The troubleshooting cards give a good overview of the data link. This will help show you the backbone of the data link (main data link wiring between 1st terminating resistor to 2nd terminating resistor) and the stubs of the data link (wiring from the backbone to each possible module)

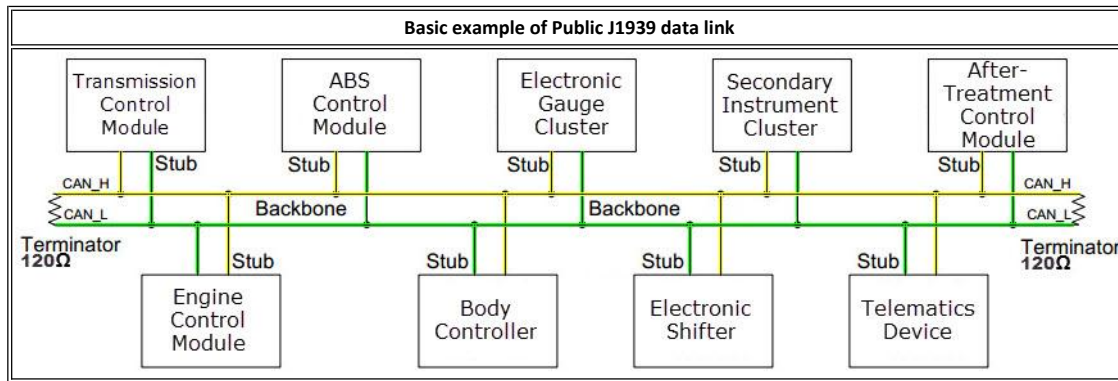

- The J1939 Splice Adapters (1024, 1025, 1026) are part of the backbone of the data link (The backbone will come in on 2 terminals and leave on 2 different terminals). The wiring from the connector to each module is a stub.
 - [HPV \(medium duty\) 1939 Troubleshooting Card](#)
 - [CE / BE Bus 1939 Troubleshooting Card](#)
 - [ProStar 1939 Troubleshooting Card](#)

NOTE:

These cards are 11" x 17" so they may not print well on regular size paper.

There are the most current troubleshooting cards that are available for printing. For more information specific to ProStar and LoneStar refer to the [Data Link Service Procedure](#) found in the [2010–2016 ProStar® Technician Manual 0000863170](#). If you wish to order the above cards, you can order them through the [Navistar Print Portal](#) from the Service Portal - Dealer Menu. The part numbers are:

Vehicle Model	Part Number
ProStar Card	S00153
DuraStar, TranStar & WorkStar Card	S00155
CE / BE Bus Card	S00154

([Back to Top](#))

Symptoms

Diagnostic Trouble Code(s) & Dashboard Indicator Light(s):

SPN	FMI	Module and Source Address (SA)	Description
PRO100	0	Synthetic Fault Code	ProStar/LoneStar J1939 Fault Code Combination Occurred
PRO100	1	Synthetic Fault Code	ProStar/LoneStar J1939 Fault Code Combination Occurred
GEN100	0	Synthetic Fault Code	A combination of J1939 Fault Codes Occurred
GEN100	1	Synthetic Fault Code	A combination of J1939 Fault Codes Occurred
GEN100	2	Synthetic Fault Code	A combination of J1939 Fault Codes Occurred
639	9	Body Controller (33)	Drivetrain message timeout
639	14	Body Controller (33)	Drivetrain message timeout
2000	19	Body Controller (33)	PTC1 (PGN 64892) not Received from Engine
2023	9	Body Controller (33)	EGC data link communication failure
2000	9	Gauge Cluster (23) / Body Controller (33)	Loss of data link from the Engine Controller
2003	9	Gauge Cluster (23) / Body Controller (33)	Loss of data link from the Transmission Controller
2011	9	Gauge Cluster (23) / Body Controller (33)	Loss of data link from the ABS Controller
2023	14	Gauge Cluster (23)	Gauge cluster lost communication with the ESC
2023	14	Gauge Cluster (23)	Gauge cluster lost communication with the Engine Controller
2033	9	Gauge Cluster (23)	Loss of data link from the ESC
560	19	Engine (0)	Transmission driveline engaged not detected on J1939
609	19	Engine (0)	ACM not detected on J1939
639	14	Engine (0)	J1939 data link error (ECM unable to transmit)
639	19	Engine (0)	J1939 data link error (ECM unable to transmit)
751	8,11	Transmission (3)	J1939 Shift Control Device
563	9,14	Transmission (3)	ABS CAN Message
639	2	Transmission (3)	J1939 Communication Link
639	14	Transmission (3)	J1939 Engine Message
639	2	Anti-Lock Brake System (ABS) (11)	Drivetrain message timeout
639	12	Anti-Lock Brake System (ABS) (11)	J1939 Serial Link
639	14	Anti-Lock Brake System (ABS) (11)	Loss of Data Link from Engine Controller
2853	14	Primary Shifter (5)	Drivetrain message timeout
886	14	Headway Controller (Forward Radar) (40)	Drivetrain message timeout

Customer Complaint(s):

- Gauges inoperative (Constant or Intermittent)
- Transmission will not go into gear
- Warning Lights
- Check Electrical Message

([Back to Top](#))

Special Tool(s) or Software

Tool Description	Tool Number	Comments
INTUNE		EZ-Tech Software

Helios		EZ-Tech Software
Diamond Logic Builder (DLB)		EZ-Tech Software
ServiceMaxx		EZ-Tech Software
Fluke DVOM	ZTSE4357	Digital Multimeter
Electrical Tester	ZTSE4858	
180-Pin Breakout Box	00-00956-08	Breakout box allows for testing engine control module and body control module systems
Breakout Harness Kit	Multiple	Use breakout harness that is applicable to the system you are testing
Terminal Test Kit	ZTSE4435C	Kit, Int. Elec. Eng. Terminal Test
Terminal Test Kit	77066-nav	Hickok Break-Out Tee Builder And Pin-Out Tool

([Back to Top](#))

Diagnostic Steps

NOTE:

- The problem must be present when taking these readings!!
- If the problem is NOT present, the reading will be within spec every time!!

NOTE:

The diagnostic checks listed below can be performed at any module connector

- Making checks at each module connector can help isolate a voltage drop / increase in resistance / short to power or ground
- Use the worksheet below to identify which modules, connectors and terminals you have checked

[Connector Terminal Worksheet](#)

- This can also help identify if the J1939_High and J1939_Low wires are pinned incorrectly at a connector
- Due to the many configurations and options available, the **terminating resistor** can be found in multiple locations (250k only vehicles)
 - Near the top of the transmission in the Powertrain Harness
 - Left frame rail (could be as far forward as the steer tire in some applications) in the Center Chassis Harness
 - Left frame rail (near the radiator bracket) in the Forward Chassis Harness (*if equipped with Forward Radar)
 - Under the bunk in the sleeper (when factory pre-wired for telematics)
 - Near the ACM
- Be aware there are multiple data links on the truck. You must ensure the terminating resistor is part of the public drivetrain data link, and not one of the private data links (body builder or engine/aftertreatment)

Step	Action	Decision
1	<ul style="list-style-type: none"> • Install a comm. device (Nexiq USB, NavCom, NavLink) the Power LED should be illuminated. <p>Is the Power LED illuminated?</p>	Yes: Continue to Step 2
		No: Verify proper power and ground to the 9-pin ATA diagnostic connector
2	<ul style="list-style-type: none"> • Turn the ignition key on, engine off (KOEO). • Attempt to establish communication with INTUNE. <p>Are you able to communicate with any of the modules?</p> <p>Note: Refer to IK0800351 to identify the module to the source address.</p>	Yes: Obtain screen shot or record all modules. Continue to Step 3
		No: Continue to Step 6
3	<ul style="list-style-type: none"> • Evaluate modules detected on the sniffer. <p>Can you identify a module that is NOT communicating?</p>	Yes: <ul style="list-style-type: none"> • Check the fuse for that module. • Load test the battery power, ignition power, ground circuits at the module connector. • If ALL power and ground circuits test okay, test the data link circuits at that module connector using the information starting at Step 6.

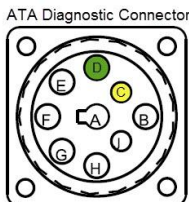
		<ul style="list-style-type: none"> Repair wiring as needed to allow the module to communicate on the data link and re-test the system.
		No: Continue to Step 4
4	<ul style="list-style-type: none"> Check for Diagnostic Trouble Codes (DTCs) <p>Are communication DTCs present in any of the modules?</p>	<p>Yes: Obtain a screen shot of the DTCs in ALL modules (ECM, ABS, TCM, BC, etc....). Continue to Step 5</p> <p>No: Evaluate complaint to determine if a data link issue is present. Determine if faults were previously cleared.</p>
5	<ul style="list-style-type: none"> Evaluate fault counts by modules <p>Do one (or more) modules show high fault counts of loss of communication fault (Other modules would have low counts)?</p>	<p>Yes:</p> <ul style="list-style-type: none"> Load test the battery power, ignition power and ground circuits at the module connector. If ALL power and ground circuits test okay, inspect the stub wiring from the module connector to the backbone of the data link. Ensure all terminals are properly seated and fully locked in the connector. Inspect for spread terminals using a terminal test kit to pin drag test the terminals. Verify the wires are pinned properly in the connector for High(+) and Low(-). If wiring goes to splice connector (heat shrink) cut open and inspect, tug on each end and check for proper weld. You will need to recrimp, solder and heat shrink after making this inspection. Use the information starting at Step 6 to assist. If an issue is identified and repaired, re-test for the complaint. If no issue is identified, continue to Step 6
		No: Continue to Step 6
6	 <p>ATA Diagnostic Connector</p> <p>C - J1939 CAN (High) Yellow D - J1939 CAN (Low) Green</p> <ul style="list-style-type: none"> Measure the voltage at the ATA Diagnostic Connector Terminal C to Gnd and D to Gnd. <p>Is there approximately 2.5 Vdc at each terminal?</p>	<p>Yes: Continue to Step 7</p> <p>No: Continue to Step 8</p>
7	<p>Note: Terminal C should have slightly higher voltage than Terminal D. Note: The voltages should not match</p> <p>Does the voltage on C and D match?</p>	<p>Yes:</p> <ul style="list-style-type: none"> A module not communicating can put 2.5Vdc on each data link wire. Monitor voltage at the 9 pin diagnostic connector while unplugging modules If the voltage changes and communication resumes suspect an issue at that module <ul style="list-style-type: none"> Load test the battery power, ignition power and ground wiring to that module Inspect the data link stub from the module connector to the backbone If no wiring issue is located suspect a faulty module If no change in voltage is noted when modules are unplugged inspect for data link High(+) and Low(-) shorted together
		No: Continue to Step 10
8	<p>Does either terminal have abnormally high voltage?</p>	<p>Yes: Check wiring for a Short to Power</p> <p>No: Continue to Step 9</p>

9	Does either terminal have abnormally low voltage?	Yes: Check wiring for a Short to Ground No: Return to Step 6 and re-test.
10	Is the voltage on Terminal C (+) higher than Terminal D (-)?	Yes: Continue to Step 11 No: <ul style="list-style-type: none"> Verify the wire is in the correct terminal location. Verify the wiring is spliced to the correct wire of the backbone.
11	<ul style="list-style-type: none"> Disconnect the batteries. Measure the resistance from Terminal C to D. 60Ω ± 5% 	Yes: Continue to Step 16 No: Continue to Step 12
12	<p>Do you have 57 - 63 ohms?</p> <ul style="list-style-type: none"> All truck harnesses should be connected for this step. Only the batteries should be disconnected. <p>Do you have approximately 120 ohms?</p>	Yes: Continue to Step 18 No: Continue to step 13
13	Does the resistance read O.L (Open)?	Yes: Inspect stub wiring from the module connector to the backbone of the data link. Repair wiring as needed and re-test. No: Continue to step 14
14	Is the resistance near 40 ohms?	Yes: Inspect for body builder components that may have installed a 3rd terminating resistor No: Continue to Step 15
15	Is the resistance < 40 ohms	Yes: Inspect data link wiring for High(+) and Low(-) shorted together No: Return to Step 11 (Resistance out of range has not been detected)
16	<ul style="list-style-type: none"> Measure the resistance from Terminal C to Gnd <p>Does resistance measure > 1000 ohms?</p>	Yes: Continue to Step 17 No: Inspect data link wiring for a short to ground.
17	<ul style="list-style-type: none"> Measure the resistance from Terminal D to Gnd <p>Does resistance measure > 1000 ohms?</p>	Yes: Continue to Step 18 No: Inspect data link wiring for a short to ground.
18	<ul style="list-style-type: none"> Measure resistance on connector 1702 (Male Terminals) <ul style="list-style-type: none"> Note: This wiring harness runs outside the cab 120Ω ± 5% <p>Is the resistance 114 - 126 ohms?</p> <p>NOTE:</p>	Yes: Continue to Step 19 No: Continue to Step 20
19	<p>It is recommended not to exceed ± 1% tolerance between the two identical resistors.</p> <ul style="list-style-type: none"> Measure resistance on connector 1702 (Female Terminals) <ul style="list-style-type: none"> Note: This wiring harness runs to the pass through on the right side the cab and continues through the dash over to the 1701 connector on the left side of the cab 120Ω ± 5% <p>Is the resistance 114 - 126 ohms?</p> <p>NOTE:</p>	Yes: Wiring issue not detected. Re-evaluate the complaint and troubleshooting. Is the issue present? If the issue is present, and the wiring checks okay, remove modules from the data link, one module at a time until communication is restored. No: Continue to Step 21
20	<p>It is recommended not to exceed ± 1% tolerance between the two identical resistors.</p> <ul style="list-style-type: none"> Locate Terminating Resistor #1. Unplug the terminating resistor and measure the resistance from terminal A to B on the resistor. Compare this to the resistance measured at Step 18 120Ω ± 5% <p>Is the resistance 114 - 126 ohms?</p>	Yes: Locate and repair open wire in the circuit between the 1702 connector and the terminating resistor. No: Replace the terminating resistor and re-test.

	<p>NOTE:</p> <p>If this resistance does not closely match the resistance measured at the 1702 connector at Step 18, it may indicate high resistance in the circuits.</p>	
21	<p>Locate terminating resistor #2.</p> <p>Unplug the terminating resistor and measure the resistance from terminal A to B on the resistor.</p> <ul style="list-style-type: none"> Compare this to the resistance measured at Step 19 120Ω ± 5% <p>Is the resistance 114 - 126 ohms?</p> <p>NOTE:</p>	<p>Yes: Locate and repair open wire in the circuit between the 1702 connector and the terminating resistor.</p> <hr/> <p>No: Replace the terminating resistor and re-test.</p>

If this resistance does not closely match the resistance measured at the 1702 connector at Step 19, it may indicate high resistance in the circuits.

Service Part(s) Information

Description	Part Number
Bulk Data Link Cable	3519281C2
Terminating Resistor	3519178C91

([Back to Top](#))

Additional Resources

- [SFN 02-94 - J1939 Troubleshooting](#)
- [Advanced Electrical Guide](#)
- [Master Service Information Page](#)

([Back to Top](#))

Connector Views

- Always refer to the wiring schematic book for the vehicle you are working on
- Verify which specific engine you are working with. This will help ensure you are viewing the correct schematic with the correct terminal locations on the ECM connector

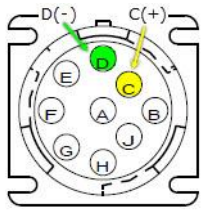
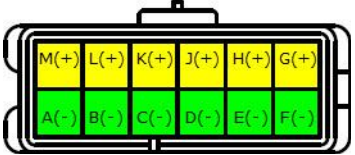

J1939 Data Link (CAN) Pin out at major connectors (Public Data Link Only)			J1939 Pins		Connector View
Module	Connector	Location	Pin (+)	Pin (-)	
Diagnostic Connector	1650	Dash panel left of steering wheel (Bus-under dash right of steering wheel)	C(+)	D(-)	
J1939 Splice Adapter Note: There is no terminal "I"	1024 1025 1026	Center of dash panel	G→M	A→F	
1702 - Male Terminals Goes to Engine	1702	Attached to wiper bracket Above valve cover	11(+)	17(-)	

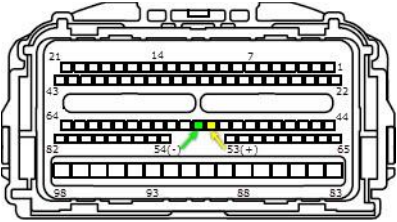
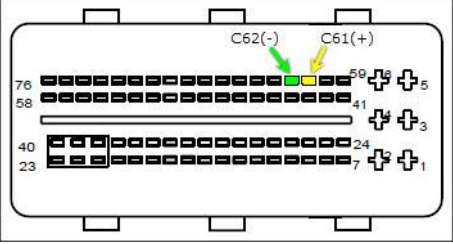
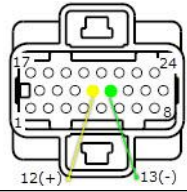
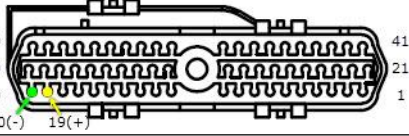
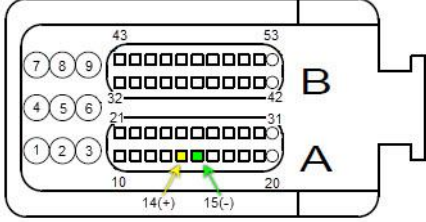
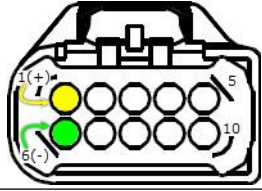
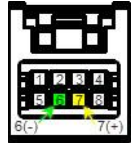
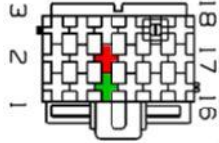
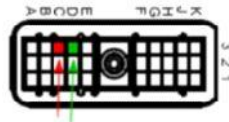
1702 - Female Terminals Goes to Cab	1702	Attached to wiper bracket Above valve cover	11(+)	17(-)	
ECM <ul style="list-style-type: none"> ◦ N13 ◦ MaxxForce 15 ◦ MaxxForce 13 / 11 (EPA 10) 	6018	Engine ECM	34(+)	47(-)	
ECM - ISX 15L	6000	Engine ECM	22(+)	46(-)	
ECM - ISB	6000	Engine ECM	22(+)	46(-)	
EIM - MaxxForce 11 / 13 (EPA 07) (Engine Interface Module)	6020	Left side of engine	12(+)	13(-)	
ECM - N9 / N10	6020M	Right side of engine	61(+)	62(-)	
ECM - MaxxForce 7 (EPA 10)	6020M	Right side of engine Mounted on air filter bracket	53(+)	54(-)	

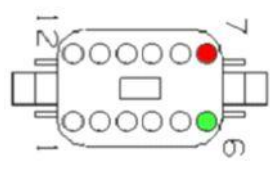
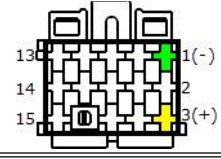
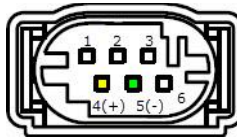
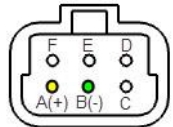
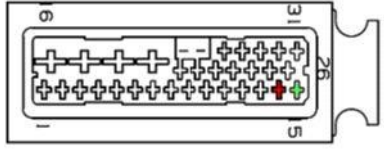
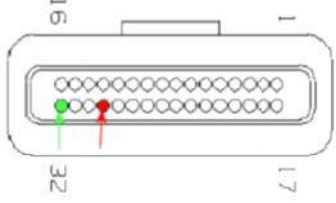
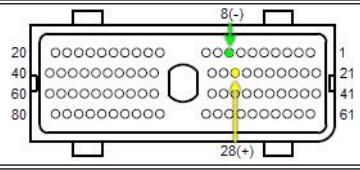
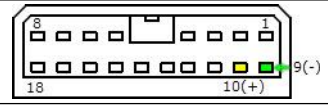
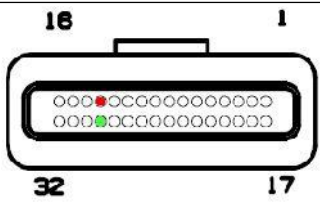
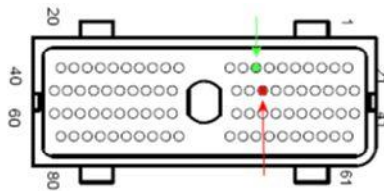
					
ECM	6020M	Left side of engine 76 Pin Chassis connector (Grey)	C61 (+)	C62(-)	
DLCII Engine ECM	X3 - 6020	Left side of engine above starter (I6) Top of left valve cover (V8)	12(+)	13(-)	
DLC NavPak Engine ECM	6007	Engine ECM - Black	19(+)	20(-)	
Engine DCU - Doser Control Unit	6340		14(+)	15(-)	
Collision Avoidance - Bendix Wingman	8903	Front bumper	1(+)	6(-)	
Bendix Wingman DIU (Driver Interface Unit)	1943M		7(+)	6(-)	
ABS - Bendix Air EC60	1400	In cab - Right kick panel	8(+)	7(-)	
ABS - Bendix Air EC30	4024	Brake ECU	C3(+)	D3(-)	
ABS - Wabco Air	9513	Wabco ECU Grey	7(+)	6(-)	

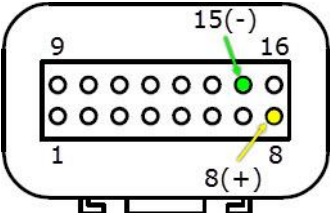
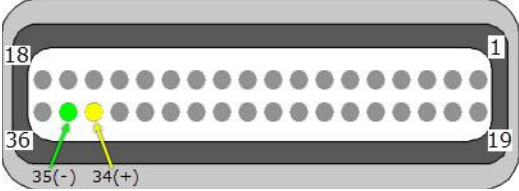
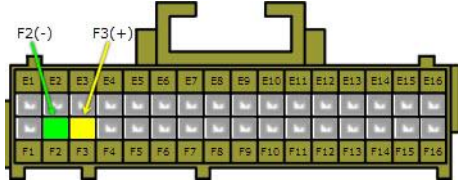
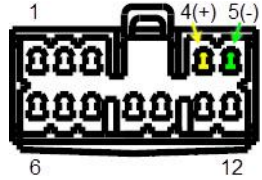
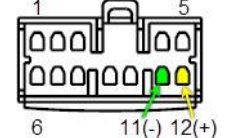
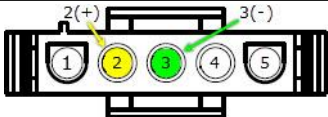
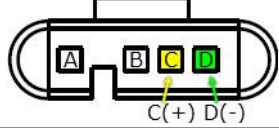
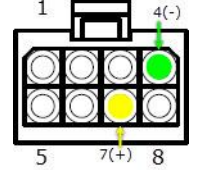
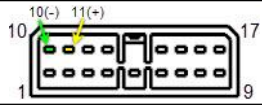
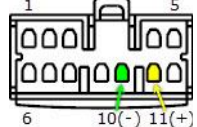
					
ABS - Wabco Air	1420	In cab - Right kick panel	3(+)	1(-)	
Collision Avoidance - Wabco OnGuard	8902	Front bumper	4(+)	5(-)	
Wabco OnGuard DIU (Driver Interface Unit)	1944		A(+)	B(-)	
Wabco Hydraulic Full Power Brakes	9511	ECU is mounted on HCU Left Frame Rail	14(+)	15(-)	
Allison LCT TCM	7305	TCM Grey	29(+)	32(-)	
TCM - Allison LCT Gen 4	7150 7151	Under cab	28(+)	8(-)	
TCM - Allison	1503	In cab	10(+)	9(-)	
Allison MD / HD 3000	7204F	TCM Black	13(+)	29(-)	
Allison MD / HD 3000 Gen 4	7151	TCM	28(+)	8(-)	
Allison TC10 Shift Selector Allison WTEC Shift Selector	1852		8(+)	15(-)	

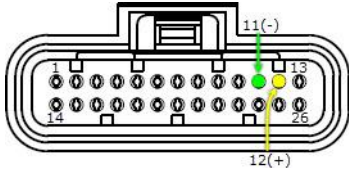
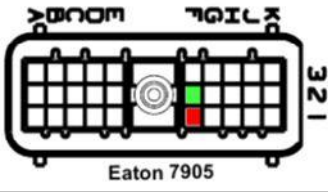
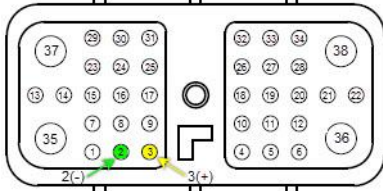
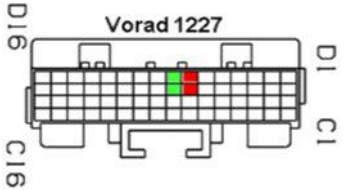
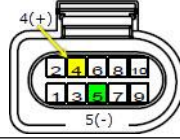
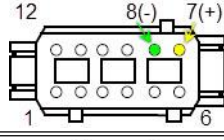
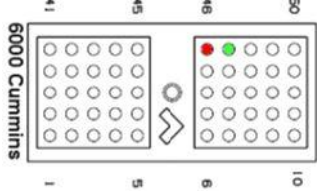
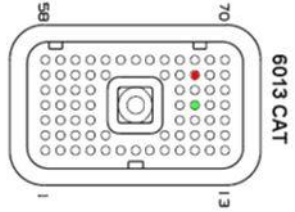
					
ESC - Electrical System Controller	1600	In cab - Left kick panel	34(+)	35(-)	
BC - Body Controller	1602 (J5)	In cab - Left kick panel	F3(+)	F2(-)	
EGC - Electronic Gauge Cluster	1500	Left side of dash	4(+)	5(-)	
EGC - Electronic Gauge Cluster	1501	Left side of dash	12(+)	11(-)	
Compass Module	1912	Behind fuse panel (HPV) Center of headliner (5000/9000)	2(+)	3(-)	
SART Module	1610	In dash - behind EGC	C(+)	D(-)	
SIC (Secondary Instrument Cluster)	1502	Center dash	7(+)	4(-)	
Optional Gauge Pack	1510		11(+)	10(-)	
AGSP (Aux Gauge Switch Pack)	1512	Right side dash	11(+)	10(-)	
TPMS (Tire pressure monitor system)	8993F	Near radiator crossmember	12(+)	11(-)	

					
Eaton Autoshift / Ultrashift DM2	7905	At Gear Shift Selector	G2(+)	G3(-)	
Eaton Autoshift / Ultrashift DM3	7105 7909 7910	TCM	3(+)	2(-)	
Eaton Vorad	1227		D7(+)	D8(-)	
Eaton Vorad VS-400	8901	Center of bumper support bracket	4(+)	5(-)	
PAM Pyro - AMP Meter Module	4087	Cowl	7(+)	8(-)	
Cummins ISM Engine ECM	6000 6014	Engine ECM	46(+)	47(-)	
CAT Engine ECM	6013	Engine ECM	50(+)	34(-)	
Meritor Freedomline Trans TCM	7103	TCM	A(+)	B(-)	

([Back to Top](#))

Service Information (Known Issues) - Potential failure location based on case file information

- 05/12/2016 - The EZ-Tech Launcher can slow down data link traffic causing fault codes to set when no issue is present.
- Typically these faults are **INACTIVE**, and have very low counts when they are caused by the service tool.
- Do not diagnose these Inactive faults without a driver complaint.

◦ Possible DTCs

SPN	FMI	Module	Description
2000	9	Body Controller Cluster	ECM Data Link Comm. Failure Loss of data link from the Engine Controller
2003	9	Body Controller Cluster	TCM Data Link Comm. Failure Loss of data link from the Transmission Controller
2011	9	Body Controller Cluster	ABS Data Link Comm. Failure Loss of data link from ABS Controller
2000	19	Body Controller	PTC1 (PGN 64892) not received from Engine
2023	9	Body Controller	EGC Data Link Comm. Failure
639	2	Brakes, System Controller	Loss of data link from Engine Controller
639	14	Brakes, System Controller	Loss of data link from Engine Controller
SID 231	2	Brakes, Power Unit	SAE J1939 Data Link
SID 231	14	Brakes, Power Unit	SAE J1939 Data Link

NOTE: For a screen shot of this occurring on the Launcher Screen [CLICK HERE](#)

- 6/9/2014 - Recent information from the field has shown a potential failure location
- A poor connection on the splice the ties the ABS module into the Back-bone of the data link was found on multiple units
 - This splice is in the cab, and the harness is common between multiple chassis and engine platforms
 - At this time (6/9/2014) the earliest build date affected is 09/23/2013
 - Anything built after this date is suspect for splice issues

◦ Possible DTCs

SPN	FMI	Module	Description
639	9	ECM	Drivetrain Message Timeout
639	9	Body Controller	J1939 Drivetrain Data Link Lost
2011	9	Body Controller	ABS Data Link Comm. Failure
2000	9	Body Controller	ECM Data Link Comm. Failure
2023	9	Body Controller	EGC Data Link Comm. Failure
2003	9	Body Controller	TCM Data Link Comm. Failure
2000	19	Body Controller	PTC1 (PGN 64892) not received from Engine
2000	9	Instrument Cluster	Loss of Data Link from Engine Controller
2011	9	Instrument Cluster	Loss of Data Link from ABS Controller
2003	9	Instrument Cluster	Loss of Data Link from the Transmission Controller
2033	9	Instrument Cluster	Loss of Data Link from the ESC

- If you have these faults and the vehicle build date is near August 2013 or Newer you will need to troubleshoot this splice in the data link if no obvious failures are found
- Follow the harness from the ABS module to the Data Link Backbone. Once you locate the splice, wiggle test that connection (also twist the splice in your fingers) while monitoring the data link resistance. (If a resistance check does not show any fault, repeat this test monitoring data link voltage as well)
- Cab temperature was effecting the data link behavior in one of the vehicles found to have this issue
- Inspecting the splice is destructive, you will need to remove the splice section use a closed barrel butt connector to crimp, solder and heat shrink the splice location. Use proper wire repair techniques as outlined in [IK0800269 - Proper Wire Repair](#)

Crimp location: Right side of cab above the ABS module, next to the HVAC box. The condensation module (if installed) will be zip tied to or near the splice.

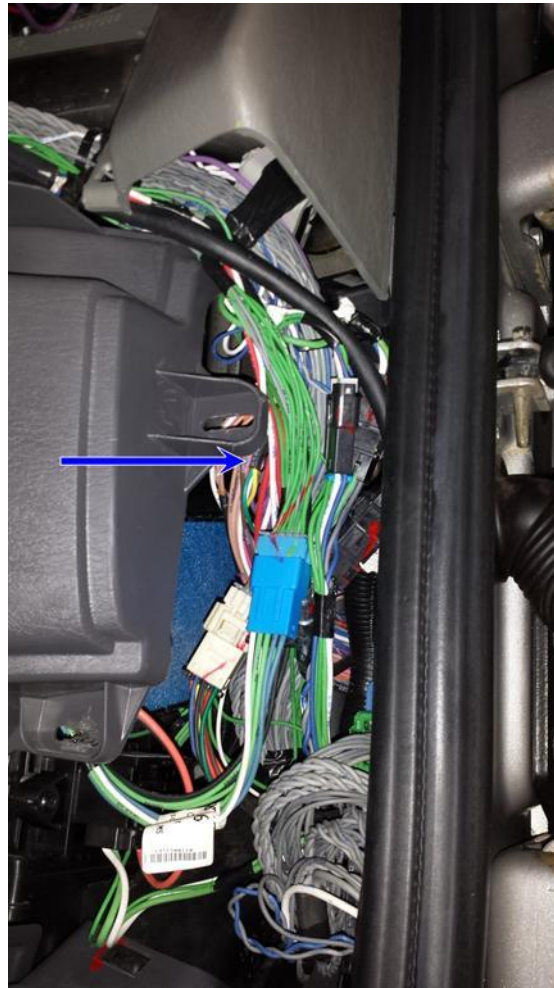

Close view of crimp location

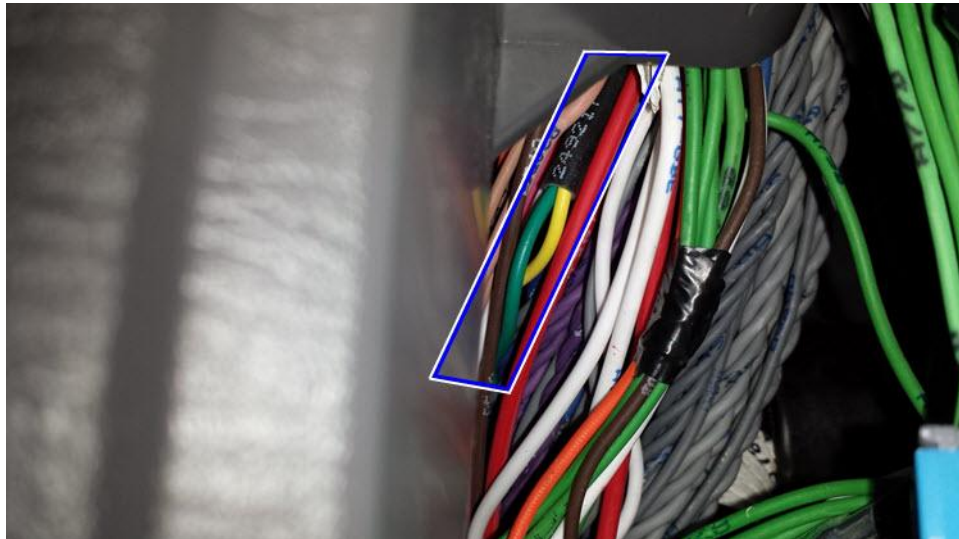

Harness removed from truck for identification

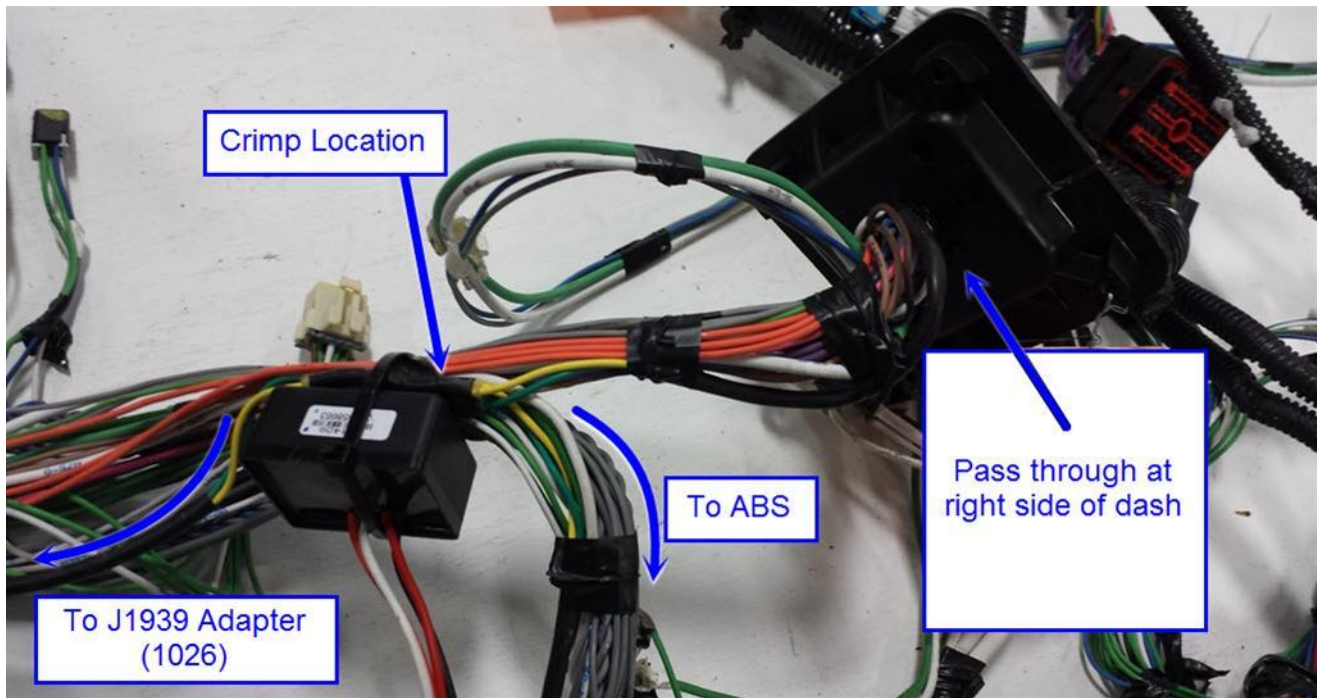

Wire condition at crimp to ABS module

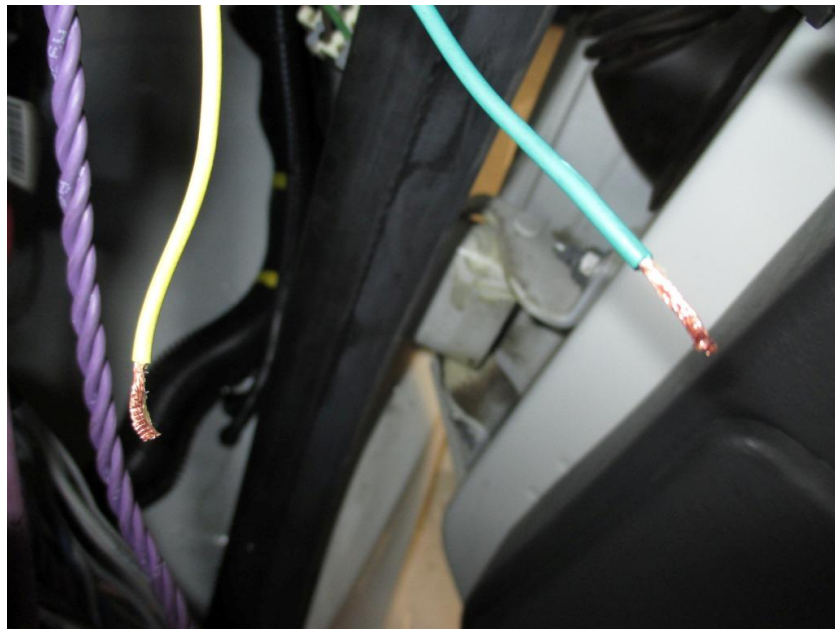

Wire condition at crimp to ABS module (2nd photo)

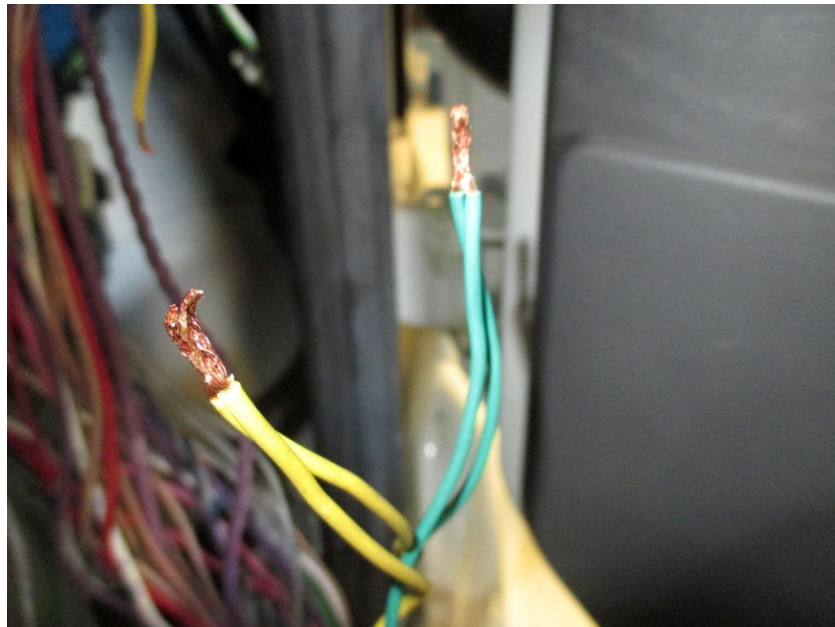

([Back to Top](#))

Examples of Modules for 250k Baud

- The **250k Baud Drivetrain data link** is a Public data link which consists of any module that is present on the data link when you plug into the ATA diagnostic connector.
- Examples:

ECM	Body Controller
TCM	Instrument Cluster
ABS	Collision Avoidance System (Wingman, OnGuard)

NOTE:
 The MaxxForce 7 TMV (Thermal Management Valve) is on the Public data link. This module will not show up on the sniffer. The ECM Engine and Chassis connector's data link terminals are connected internally to the module. E13 and C53 are internally connected. E14 and C54 are internally connected.

- The **Body Builder data link** is a Private data link which consists of modules communicating to each other. You cannot use a diagnostic tool to communicate with this private data link.
- Examples:

Body Controller (This module is on the public and private data link independently)
Sleeper HVAC (Standard and No-Idle systems)
RPM (Remote Power Module)

- The **Engine data link** is a Private data link which consists of engine related modules communicating to each other. You cannot use a diagnostic tool to communicate with this private data link.
- Examples:

EPA07 MaxxForce 11 / 13	EPA10 N13 SCR	EPA10 ISX15 SCR
ECM	ECM	ECM
EIM	ACM	VGT
ACM	AFT Modules / Sensors	AFT Modules / Sensors

([Back to Top](#))

500k Baud Vehicle Architecture - Phase 1

This can be properly identified by looking in the components tab of the vehicle and looking for a GREEN 9-Pin connector and feature:

0508095 - ELECTRICAL SYSTEM ENHANCED VCM FUNCTIONS for VCM Enhanced Functions

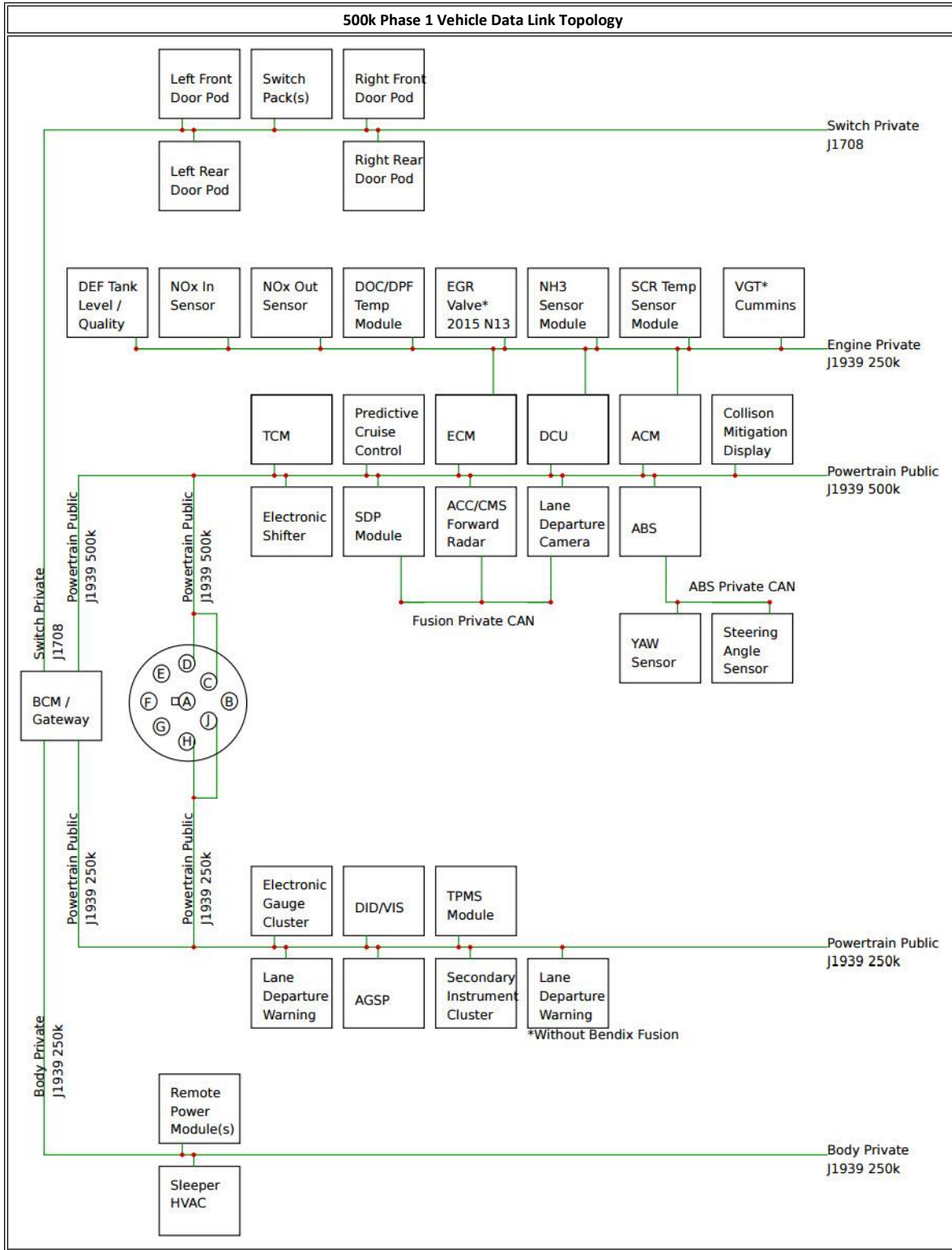

([Back to Top](#))

500k Baud Vehicle Architecture - Phase 2

This can be properly identified by looking in the components tab of the vehicle and looking for a GREEN 9-Pin connector and feature:

0508097 - ELEC SYS MUX COMMON ARCHITECTURE for Electrical Common Architecture System

- This feature and vehicle architecture launched with the LT Model

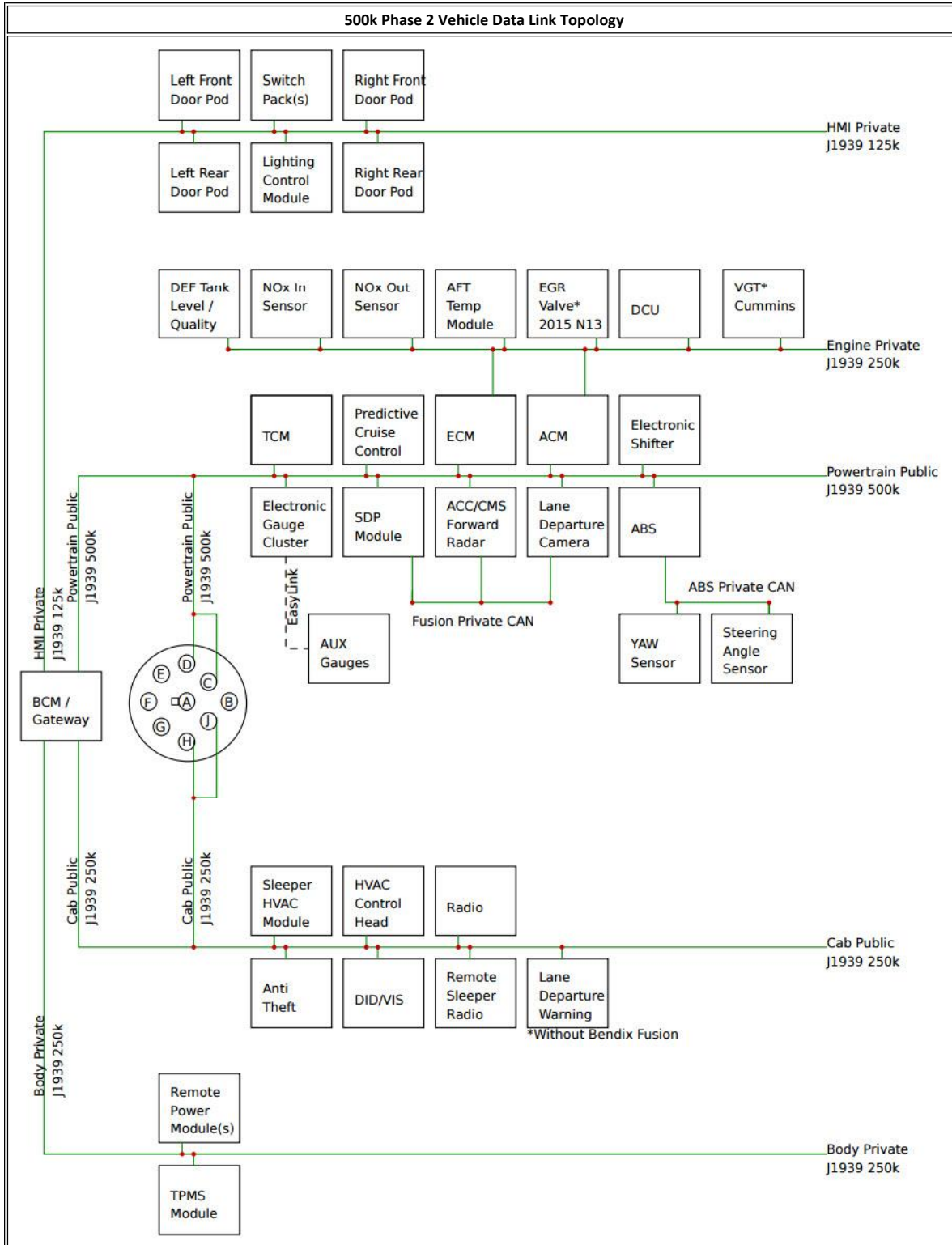

[\(Back to Top \)](#)

 Hide Details

Feedback Information

Viewed: 103298

Helpful: 10712

Not Helpful: 7041

No Feedback Found