

December 2017
FL745AB
NHTSA #17V-521
Transport Canada #17-407
REVISED NOTICE

Subject: Western Star 4900 Front Springs

Models Affected: Specific Western Star 4900 vehicles manufactured November 18, 2016, through July 21, 2017.

General Information

Daimler Trucks North America LLC (DTNA), on behalf of its wholly owned subsidiary, Western Star Truck Sales, Inc., has decided that a defect that relates to motor vehicle safety exists on the vehicles mentioned above.

There are approximately 61 vehicles involved in this campaign.

On certain vehicles, the specified front axle weight limit may be greater than that of the spring capacity. If the axle load exceeds the maximum weight capacity of the springs there may be an increased risk of spring fatigue. Excessive spring fatigue may cause the front axle to separate from the vehicle leading to an increased risk of a crash.

The front axle springs will be replaced with higher capacity springs.

REVISION: The part numbers for groups FL745-A and FL745-B have been corrected in the Replacement Parts Table.

Additional Repairs

Dealers must complete all outstanding Recall and Field Service campaigns prior to the sale or delivery of a vehicle. A Dealer will be liable for any progressive damage that results from its failure to complete campaigns before sale or delivery of a vehicle.

Owners may be liable for any progressive damage that results from failure to complete campaigns within a reasonable time after receiving notification.

Work Instructions

Please refer to the attached work instructions. Prior to performing the campaign, check the vehicle for a completion sticker (Form WAR260).

Replacement Parts

Replacement parts are now available and can be obtained by ordering the kit or part number(s) listed below from your facing Parts Distribution Center.

If our records show your dealership has ordered any vehicles involved in campaign number FL745, a list of the customers and vehicle identification numbers will be available in OWL. Please refer to this list when ordering parts for this recall.

December 2017
FL745AB
NHTSA #17V-521
Transport Canada #17-407
REVISED NOTICE

Table 1 - Replacement Parts for FL745

Campaign Number	Kit Number	Part Description	Part Number	Qty. per Vehicle
FL745A	N/A	SPACER-FR AXLE,105MM X 101.6MM	16-15105-105	2 ea
		PIN-DOWEL,.75 OD X 4.00 LG	23-09271-400	2 ea
		U-BOLT	A 681 322 10 25	4 ea
FL745B	N/A	SPACER-FR AXLE,75MM X 101.6MM	16-15105-075	2 ea
		PIN-DOWEL,.75 OD X 2.62 IN	23-09271-262	2 ea
		U-BOLT-SUSP, .875-14X230	A 681 322 04 25	4 ea
FL745AB	N/A	PIN-SPLIT RING,SHACKLE	16-09598-000	6 ea
		NUT-HEX,HI,7/8-14,C,TX,1.172	23-00461-007	8 ea
		SPR-14.6 TPR,4"/59,TSTS,WST	A16-19722-003	2 ea
		COMPLETION STICKER	WAR260	1 ea

Table 1

Removed Parts

U.S. and Canadian Dealers, please follow Warranty Failed Parts Tracking shipping instructions for the disposition of all removed parts. Export distributors, please destroy removed parts unless otherwise advised.

Labor Allowance

Table 2 - Labor Allowance

Campaign Number	Procedure	Time Allowed (hours)	SRT Code	Corrective Action
FL745AB	Remove and replace both front spring assemblies	2.7	996-R035A	12-Repair Recall/Campaign

Table 2

IMPORTANT: When the Recall has been completed, locate the base completion label in the appropriate location on the vehicle, and attach the red completion sticker provided in the recall kit (Form WAR260). If the vehicle does not have a base completion label, clean a spot on the appropriate location of the vehicle and first attach the base completion label (Form WAR259). If a recall kit is not required or there is no completion sticker in the kit, write the recall number on a blank sticker and attach it to the base completion label.

Claims for Credit

You will be reimbursed for your parts, labor, and handling (landed cost for Export Distributors) by submitting your claim through the Warranty system within 30 days of completing this campaign. Please reference the following information in OWL:

REVISION: The part numbers for groups FL745-A and FL745-B have been corrected in the Replacement Parts Table.

- Claim type is **Recall Campaign**.
- In the FTL Authorization field, enter the campaign number and appropriate condition code (**FL745-A** or **FL745-B**).
- In the Primary Failed Part Number field, enter **25-FL745-000**.
- In the Parts field, enter the appropriate kit or part number(s) as shown in the Replacement Parts Table.

**December 2017
FL745AB
NHTSA #17V-521
Transport Canada #17-407
REVISED NOTICE**

- In the Labor field, first enter the appropriate SRT from the Labor Allowance Table. Administrative time will be included automatically as SRT 939-0010A for 0.3 hours.
- The VMRS Component Code is **016-002-001** and the Cause Code is **A1 - Campaign**.
- **U.S. and Canada -- Reimbursement for Prior Repairs.** When a customer asks about reimbursement, please do the following:
 - Accept the documentation of the previous repair.
 - Make a brief check of the customer's paperwork to see if the repair may be eligible for reimbursement. (See the "Copy of Owner Letter" section of this bulletin for reimbursement guidelines.)
 - Submit an OWL Recall Pre-Approval Request for a decision.
 - Include the approved amount on your claim in the Other Charges section.
 - Attach the documentation to the pre-approval request.
 - If approved, submit a based on claim for the pre-approval.
 - Reimburse the customer the appropriate amount.

IMPORTANT: OWL must be viewed prior to performing the recall to ensure the vehicle is involved and the campaign has not been previously completed. Also, check for a completion sticker prior to beginning work.

U.S. and Canadian dealers, contact the Warranty Campaigns Department via Web inquiry at DTNAConnect.com / WSC, or the Customer Assistance Center at (800) 385-4357, after normal business hours, if you have any questions or need additional information. Export distributors, submit a Web inquiry or contact your International Service Manager.

U.S. and Canadian Dealers: To return excess kit inventory related to this campaign, U.S. dealers must submit a Parts Authorization Return (PAR) to the Memphis PDC. Canadian dealers must submit a PAR to their facing PDC. All kits must be in resalable condition. PAR requests must include the original purchase invoice number. Export Distributors: Excess inventory is not returnable.

The letter notifying U.S. and Canadian vehicle owners is included for your reference.

Please note that the National Traffic and Motor Vehicle Safety Act, as amended (Title 49, United States Code, Chapter 301), requires the owner's vehicle(s) be corrected within a reasonable time after parts are available to you. The Act states that failure to repair a vehicle within 60 days after tender for repair shall be prima facie evidence of an unreasonable time. However, circumstances of a particular situation may reduce the 60 day period. Failure to repair a vehicle within a reasonable time can result in either the obligation to (a) replace the vehicle with an identical or reasonably equivalent vehicle, without charge, or (b) refund the purchase price in full, less a reasonable allowance for depreciation. The Act further prohibits dealers from selling a vehicle unless all outstanding recalls are performed. Any lessor is required to send a copy of the recall notification to the lessee within 10 days. Any subsequent stage manufacturer is required to forward this notice to its distributors and retail outlets within five working days.

December 2017
FL745AB
NHTSA #17V-521
Transport Canada #17-407
REVISED NOTICE

Copy of Notice to Owners

Subject: Western Star 4900 Front Springs

For the Notice to U.S. Customers: This notice is sent to you in accordance with the National Traffic and Motor Vehicle Safety Act. **For the Notice to Canadian Customers:** This notice is sent to you in accordance with the Canadian Motor Vehicle Safety Act.

Daimler Trucks North America LLC (DTNA), on behalf of its wholly owned subsidiary, Western Star Truck Sales, Inc., has decided that a defect that relates to motor vehicle safety exists on specific Western Star 4900 vehicles manufactured November 18, 2016, through July 21, 2017.

On certain vehicles, the specified front axle weight limit may be greater than that of the spring capacity. If the axle load exceeds the maximum weight capacity of the springs there may be an increased risk of spring fatigue. Excessive spring fatigue may cause the front axle to separate from the vehicle leading to an increased risk of a crash.

The front axle springs will be replaced with higher capacity springs.

Please contact an authorized Daimler Trucks North America dealer to arrange to have the Recall performed and to ensure that parts are available at the dealership. To locate an authorized dealer, search online at www.Daimler-TrucksNorthAmerica.com / Contact Us / Find a Dealer. The Recall will take approximately three hours and will be performed at no charge to you.

You may be liable for any progressive damage that results from your failure to complete the Recall within a reasonable time after receiving notification.

If you do not own the vehicle that corresponds to the identification number(s) which appears on the Recall Notification, please return the notification to the Warranty Campaigns Department with any information you can furnish that will assist us in locating the present owner. If you have leased this vehicle, Federal law requires that you forward this notice to the lessee within 10 days. If you are a subsequent stage manufacturer, Federal law requires that you forward this notice to your distributors and retail outlets within five working days. If you have paid to have this recall condition corrected prior to this notice, you may be eligible to receive reimbursement. Please see the reverse side of this notice for details.

For the Notice to U.S. Customers: If you have questions about this Recall, please contact the Warranty Campaigns Department at (800) 547-0712, 7:00 a.m. to 4:00 p.m. Pacific Time, Monday through Friday, e-mail address DTNA.Warranty.Campaigns@Daimler.com, or the Customer Assistance Center at (800) 385-4357 after normal business hours. If you are not able to have the defect remedied without charge and within a reasonable time, you may wish to submit a complaint to the Administrator, National Highway Traffic Safety Administration, 1200 New Jersey Avenue, SE., Washington, DC 20590; or call the Vehicle Safety Hotline at (888) 327-4236 (TTY: 800-424-9153); or to <http://www.safercar.gov>. **For the Notice to Canadian Customers:** If you have questions about this Recall, please contact the Warranty Campaigns Department at (800) 547-0712, 7:00 a.m. to 4:00 p.m. Pacific Time, Monday through Friday, e-mail address DTNA.Warranty.Campaigns@Daimler.com, or the Customer Assistance Center at (800) 385-4357 after normal business hours.

We regret any inconvenience this action may cause but feel certain you understand our interest in motor vehicle safety.

WARRANTY CAMPAIGNS DEPARTMENT

Enclosure

December 2017
FL745AB
NHTSA #17V-521
Transport Canada #17-407
REVISED NOTICE

Reimbursement to Customers for Repairs Performed Prior to Recall

If you have already **paid** to have this recall condition corrected you may be eligible to receive reimbursement.

Requests for reimbursement may include parts and labor. Reimbursement may be limited to the amount the repair would have cost if completed by an authorized Daimler Trucks North America LLC dealer. The following documentation must be presented to your dealer for consideration for reimbursement.

Please provide original or clear copies of all receipts, invoices, and repair orders that show:

- The name and address of the person who paid for the repair
- The Vehicle Identification Number (VIN) of the vehicle that was repaired
- What problem occurred, what repair was done, when the repair was done
- Who repaired the vehicle
- The total cost of the repair expense that is being claimed
- Proof of payment for the repair (such as the front and back of a cancelled check or a credit card receipt)

Reimbursement will be made by check from your Daimler Trucks North America LLC dealer.

Please speak with your Daimler Trucks North America LLC authorized dealer concerning this matter.

December 2017
FL745AB
NHTSA #17V-521
Transport Canada #17-407
REVISED NOTICE

Work Instructions

Subject: Western Star 4900 Front Springs

Models Affected: Specific Western Star 4900 vehicles manufactured November 18, 2016, through July 21, 2017.

REVISION: The part numbers for groups FL745-A and FL745-B have been corrected in the Replacement Parts Table.

Spring Assembly Replacement

1. Check the base label (Form WAR259) for a completion sticker for FL745 (Form WAR260) indicating this work has been completed. The base label is usually located on the passenger-side door, about 12 inches (30 cm) below the door latch. If a completion sticker is present, no work is needed. If a completion sticker is not present, proceed to the next step.
2. Shut off the engine, set the parking brake, and chock the tires. Open the hood.
3. Disconnect both shock absorbers. See [Fig. 1](#).
4. Raise the vehicle, and support the frame rails with jack stands behind the rear hanger of the front suspension.

IMPORTANT: Make sure the frame rails are level and an equal distance off the ground.

NOTE: Replace both front suspension springs at the same time.

5. Remove the grease zerk fittings from the spring pins.
6. Using the floor jack, support the axle underneath the center of the spring, then remove the U-bolts and the axle stop/shock absorber mount.
7. Lower the axle and remove the spring spacer and caster shim. Note the taper direction of the caster shim so that it will not be reversed during the installation.
8. Raise the axle back up to support the spring and remove some of the load from the spring.
9. Disconnect the front of the spring from the spring drive bracket.
 - 9.1 Remove the 4 retaining bolts from the retainers at the front spring drive bracket.
 - 9.2 Using special tool J-49860, unthread the front spring pin from the spring eye. See [Fig. 1](#).
10. Disconnect the rear of the spring from the shackle bracket.
 - 10.1 Remove the lower retaining bolts from the inboard and outboard shackle links.
 - 10.2 Using special tool J-49860, unthread the lower rear spring pin from the spring eye and shackle links.
11. Lower the spring and the axle, then remove the spring.
12. Using multipurpose chassis grease, lubricate both spring pins, the shackle pin, and the inside surfaces of the bushings.
13. Loosely position the new spring on top of the axle, with the new alignment pin in the hole in the top of the axle.

December 2017
FL745AB
NHTSA #17V-521
Transport Canada #17-407
REVISED NOTICE

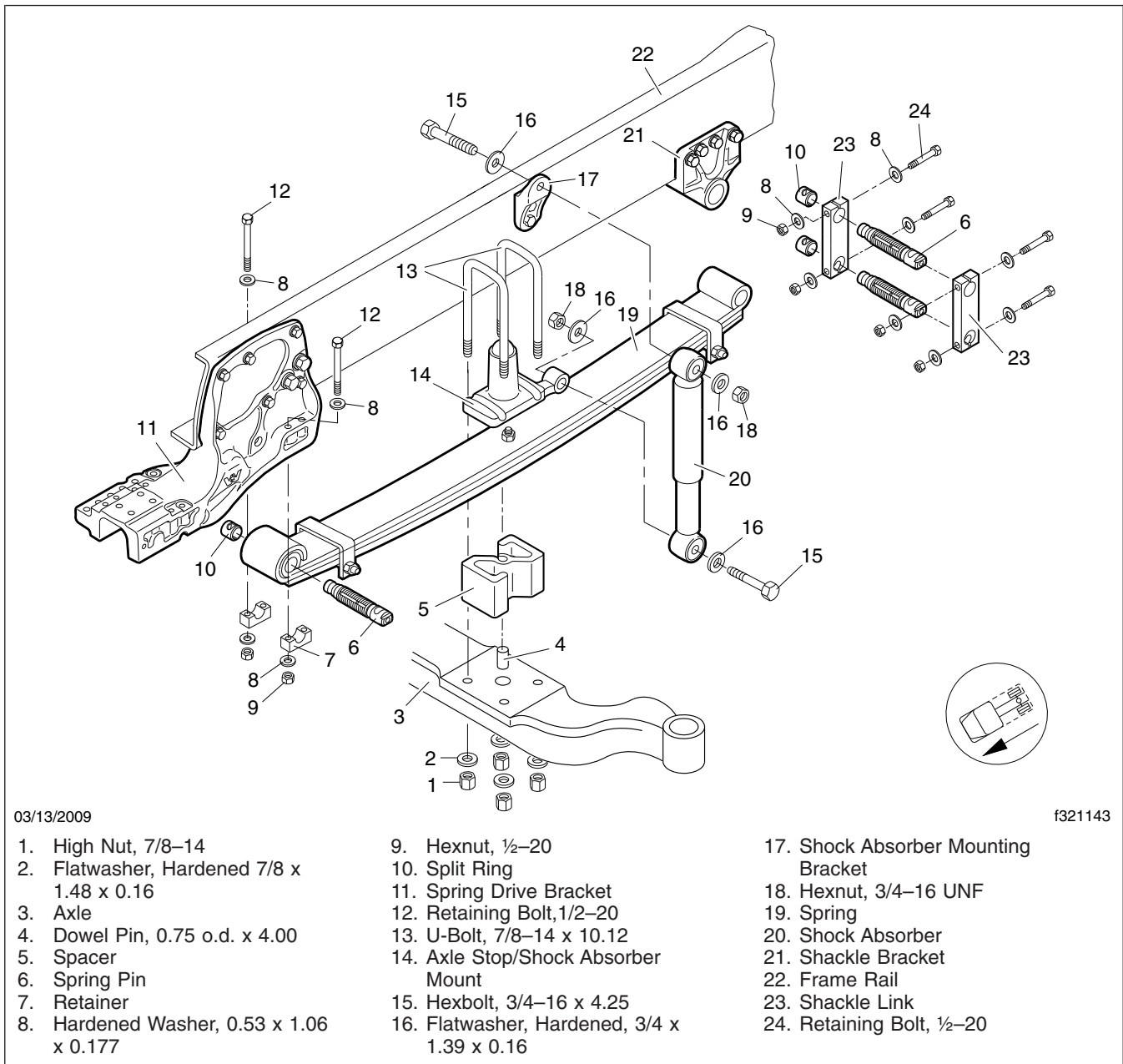

Fig. 1, Drop Hanger Front Suspension with Threaded Spring Pins

December 2017
FL745AB
NHTSA #17V-521
Transport Canada #17-407
REVISED NOTICE

NOTICE

Failure to apply Alumilastic or similar compound will result in electrolytic corrosion of dissimilar metal components, and will damage the suspension system.

14. Connect the rear of the spring as follows.
 - 14.1 Place the floor jack under the axle, then raise it until the rear spring eye aligns with the holes in the shackles.
 - 14.2 Using special tool J-49860, thread the rear spring pin through the outboard shackle link, the spring eye, then the inboard shackle link. Take care not to push the new split ring out of the inboard shackle link.
 - 14.3 Apply Alumilastic® or similar compound to all areas of the aluminum shackle link that contacts other metal. This includes all capscrews, washers, and locknuts that contact the aluminum shackle link.
 - 14.4 Insert the lower retaining bolt, with a hardened washer, through the inboard shackle link. Do not install the retaining bolt through the outboard shackle link at this time.
15. Connect the front of the spring as follows.
 - 15.1 Align the forward spring eye in the spring drive bracket.
 - 15.2 Thread the spring pin through the spring eye, then set the split-ring on the inboard end of the spring pin.
 - 15.3 Install the retaining bolts down through the spring drive bracket and attach the retainers. Tighten the nuts evenly to maintain equal clearance between the retainers and the spring drive bracket, but do not fully tighten them at this time. They need to be loose enough to adjust. See [Fig. 2](#).
16. Using the floor jack, lower the axle until the spring hangs freely.
17. Attach the rear of the spring as follows.
 - 17.1 Using the threaded spring pin, center the lower rear spring pin in the shackle bracket. The gap on each side should be within 0.080 inch (20 mm) of the other side. The minimum gap on each side is 0.020 inch (0.5 mm). See [Fig. 3](#).
 - 17.2 After the spring is correctly positioned, install the lockbolt through the outboard shackle link, then tighten the bolts in both the inboard and outboard shackle links 45 lbf-ft (61 N·m).
18. Adjust the front of the spring.
 - 18.1 Using the threaded spring pin to adjust the position, center the front spring pin in the drive bracket. The nominal gap on each side is 0.063 inch (1.60 mm). Maintain a minimum gap of 0.020 inch (0.5 mm) on each side. See [Fig. 4](#).
 - 18.2 Tighten the nuts on the retainer bolts 60 to 76 lbf-ft (81 to 103 N·m).
19. Install the grease zerks into the spring pins.
20. Lower the axle and place the new spacer and caster shim on the front axle in the position referenced during removal.
21. Using the jack, raise the axle until the spring spacer touches the spring, then place the axle stop/shock-absorber mount on top of the spring.

December 2017
FL745AB
NHTSA #17V-521
Transport Canada #17-407
REVISED NOTICE

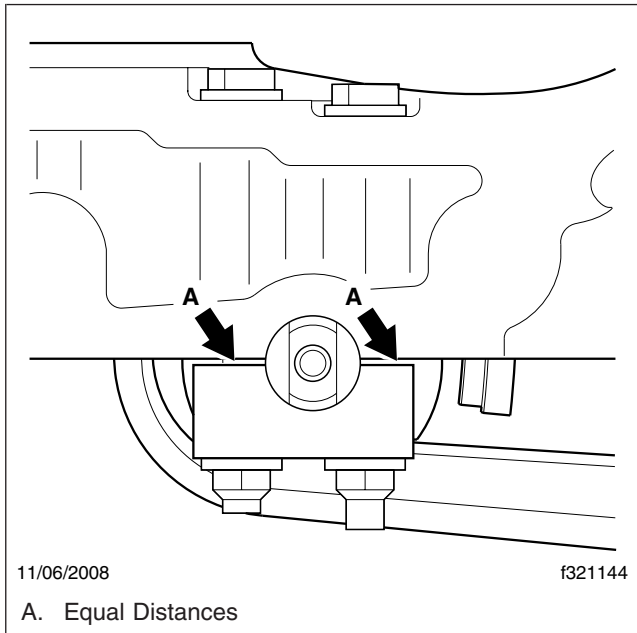

Fig. 2, Spring Drive Bracket and Retainer Installation

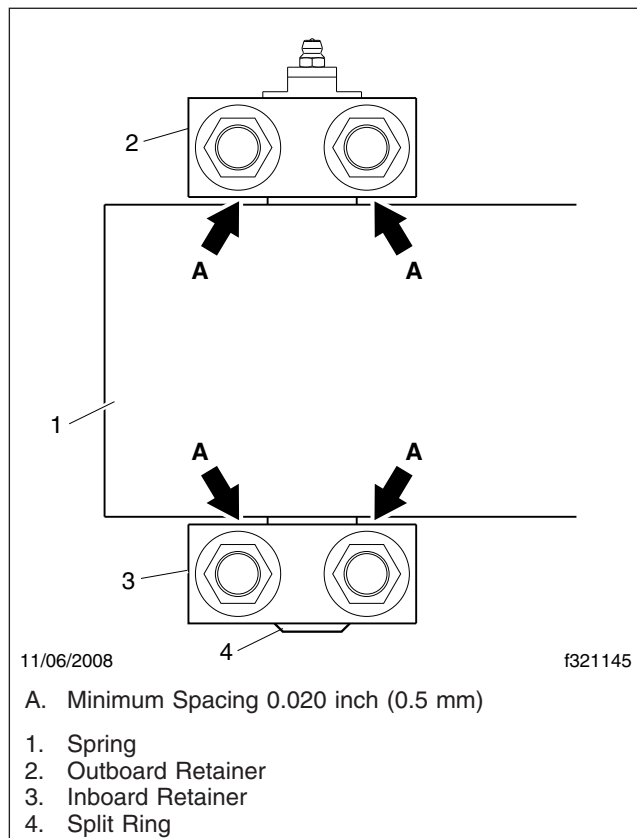

Fig. 4, View From Underneath the Forward Spring Eye

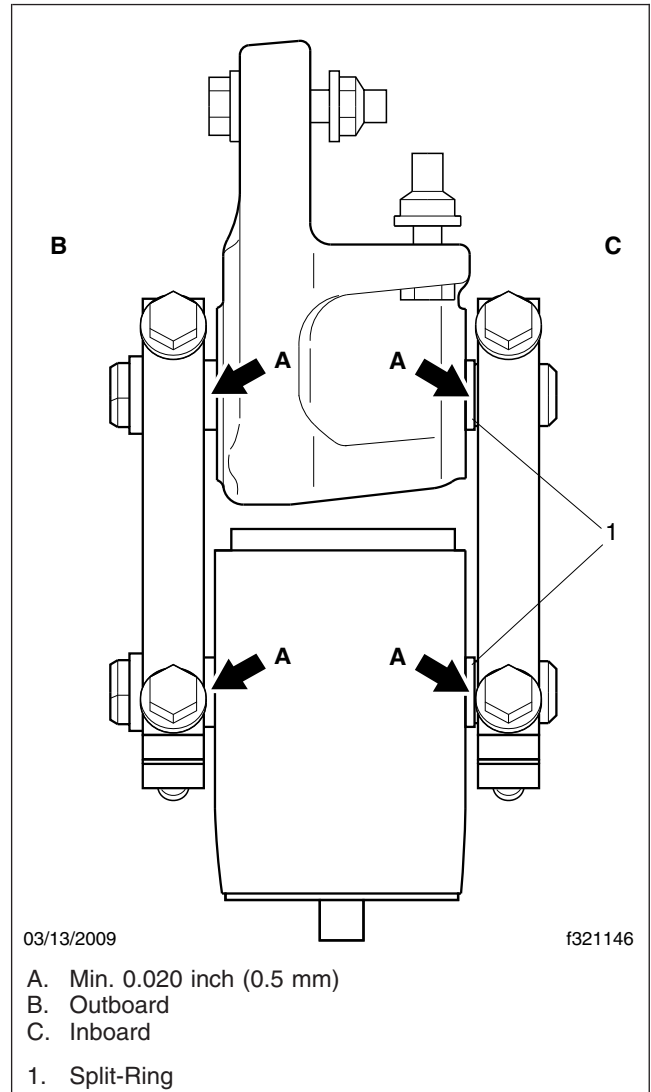

Fig. 3, View from Rear of Spring Looking Forward

December 2017
FL745AB
NHTSA #17V-521
Transport Canada #17-407
REVISED NOTICE

NOTICE

Failure to retighten the U-bolt fasteners as instructed could result in spring breakage or abnormal tire wear.

22. Install the new U-bolts. Tighten the new U-bolt high nuts in stages and in a diagonal pattern as shown in [Table 3](#) and [Fig. 5](#).

U-Bolt Torque Values	
Stage	Torque: lbf·ft (N·m)
1	Hand-tighten
2	60 (81)
3	200 (271)
4	420–500 (571–680)

Table 3, U-Bolt Torque Values

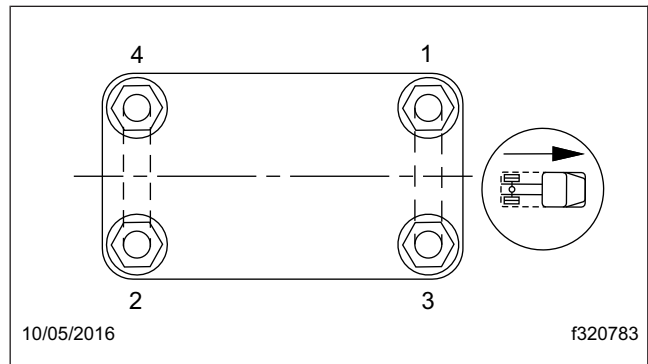

Fig. 5, Tightening Pattern for U-Bolt (or Clamp Bolt) High Nuts

23. Remove the jack stands and lower the vehicle to the ground.
24. Wipe all dirt from the grease fittings on the spring pins and the shackle pin. Apply multipurpose chassis grease with a pressure gun until grease appears at the opposite end of the pin.
25. Remove the jack stands from the chassis, and lower the vehicle.
26. Install both front shock absorbers, and tighten the bolts 200 lbf·ft (271 N·m).
27. Close the hood.
28. Clean a spot on the base label (Form WAR259). Write the campaign number, FL745, on a blank red completion sticker (Form WAR260) to indicate the work has been completed and attach it to the base label.