



Technical Service Bulletin

46 Squeal from front brakes

46 17 77 2043706/4 August 14, 2017. Supersedes Technical Service Bulletin Group 46 number 16-57 dated September 27, 2016 for reasons listed below.

Model(s)	Year	VIN Range	Vehicle-Specific Equipment
Q5	2013	000001 - 047566	2.0 and 3.0 engines

Condition

REVISION HISTORY		
Revision	Date	Purpose
4	-	Revised <i>Warranty</i> (Updated Claim Type) Revised <i>Service</i> (Added Note)
3	09/27/2016	Revised <i>Warranty</i> (Updated Claim Type)
2	07/15/2016	Revised <i>Service</i> (Updated embedding procedure) Revised <i>Warranty</i> (Updated Claim Type)

Customer reports hearing a squeal noise from the front brakes in the following conditions:

When:	During first brake application in the morning, with cold brakes
Speed:	Below 20 mph
Temperature:	Below 40°F
Conditions:	High humidity



Technical Service Bulletin



Tip: For an example of the sound, see the video located at: <https://audi-external.kzoplatform.com/swf/player/319> (Figure 1).



Figure 1. QR code for viewing the video with a QR code reader on phones and tablets. Alternatively, the video can be accessed through computer internet browsers at the link provided in this bulletin.

Technical Background

Not applicable.

Production Solution

Not applicable.

Service

Before proceeding, check the following table to confirm that this bulletin applies:

Model	Model years	Front brakes (Brembo) disc size
Q5 2.0TFSI	2013	320 x 30 mm
Q5 3.0TFSI	2013	345 x 30 mm



Note:

- This TSB only applies to Q5 models listed in the table above.
- This bulletin does not apply if: The brake discs and/or brake pads are at or exceeding wear limits. Or from improper operation or misuse of the vehicle.



Technical Service Bulletin



Tip: Rust/corrosion build-up, grooves, or glazing on the braking surface of the brake disc may cause brake noise and must be considered when replacing brake pads.

1. Replace the front brake pads according to the instructions in Elsa at Repair Manual, *Chassis Brake System >> 46 Mechanical Components >> Front Brakes >> Brake Pads, Removing and Installing, Brake 1LB and 1LC or Brake Pads, Removing and Installing, Brake 1LE and 1LP.*



Note:

- Some vehicles may have two shims glued to the back of the front brake pads (Figure 2). **Do not** transfer these shims to the new pads.
- New brake pads have an adhesive backing that should be used to properly attach the pads to the caliper.

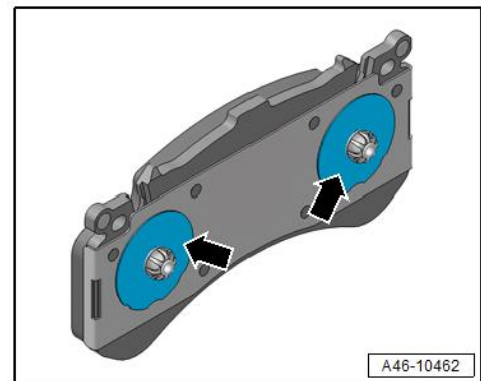

Figure 2. Shims on back of front brake pads.

The following steps must be followed to ensure proper installation of the pads:

- Thoroughly clean and dry each piston (Figure 2, arrows) to ensure that the new pads will properly adhere to the pistons.
- Do not apply any lubricants to the pads or calipers.
- After the pads are installed in the calipers, apply full pedal pressure for at least 10 seconds to ensure proper adhesion of the pads to the pistons.
- In order to allow the glue to set, do not drive the vehicle for 10 minutes after new pads have been installed.

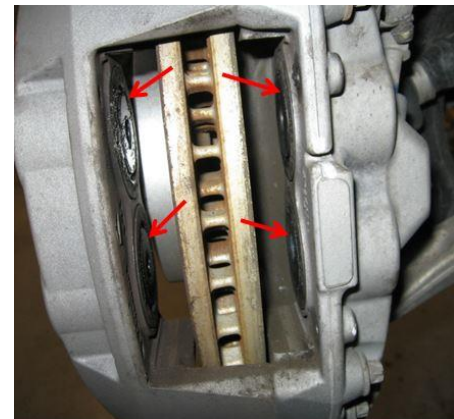

Figure 2. Location of pistons.

2. Brake embedding:

- A. Perform 10 stops from approximately 35 mph to 10 mph with medium pedal pressure.



Technical Service Bulletin

- B. Drive for approximately 2 minutes at approximately 40 mph without braking to allow the brakes to cool down.
- C. Repeat steps A and B if necessary.



Note:

Do not perform ABS stops as a way of embedding the brakes. Brake pads and discs may be permanently damaged if brakes are overheated prior to being properly embedded.

Warranty

Claim Type:	<ul style="list-style-type: none">• 110 up to 48 Months/50,000 Miles.• If vehicle is outside any warranty, this Technical Service Bulletin is informational only.		
Service Number:	4636		
Damage Code:	0010		
Labor Operations:	2 wheels remove + reinstall	4405 2000	20 TU
	Brake pads, front remove + reinstall	4636 2050	50 TU
Diagnostic Time:	Road test prior to service procedure	0121 0002	10 TU
	Road test after service procedure	0121 0004	10 TU
	Technical diagnosis at dealer's discretion (Refer to Section 2.2.1.2 and Audi Warranty Online for DADP allowance details)		
Claim Comment:	As per TSB #2043706/4		

All warranty claims submitted for payment must be in accordance with the *Audi Warranty Policies and Procedures Manual*. Claims are subject to review or audit by Audi Warranty.



Technical Service Bulletin

Required Parts and Tools

Part Number	Part Description	Quantity
8R0698151L (3.0 TFSI)	1 set of front brake pads	1
8R0698151L (2.0 TFSI)	1 set of front brake pads	1
Check ETKA for applicable part number	Contact (wear sensor)	1

Additional Information

All parts and service references provided in this TSB (2043706) are subject to change and/or removal. Always check with your Parts Department and service manuals for the latest information.

©2017 Audi of America, Inc. All rights reserved. Information contained in this document is based on the latest information available at the time of printing and is subject to the copyright and other intellectual property rights of Audi of America, Inc., its affiliated companies and its licensors. All rights are reserved to make changes at any time without notice. No part of this document may be reproduced, stored in a retrieval system, or transmitted in any form or by any means, electronic, mechanical, photocopying, recording, or otherwise, nor may these materials be modified or reposted to other sites without the prior expressed written permission of the publisher.