



# Technical Service Bulletin

---

## 39 All-wheel drive coupling does not work (DTC C111204)

39 17 17 2043144/3 June 27, 2017. Supersedes Technical Service Bulletin Group 39 number 16-16 dated July 22, 2016 for reasons listed below.

Model(s)	Year	VIN Range	Vehicle-Specific Equipment
A3, Q3	2015 - 2016	All	quattro all-wheel drive
TT	2016	All	quattro all-wheel drive

## Condition

REVISION HISTORY		
Revision	Date	Purpose
3	-	Revised <i>Required Parts and Tools</i> (Added bolt)
2	07/22/2016	Revised <i>Service</i> (Additional diagnostic step) Revised <i>Required Parts and Tools</i> (Added bolts)
1	02/01/2016	Initial publication

One or both of the following issues is present:

- All-wheel drive does not work.
- The EPC warning lamp is illuminated.

The following DTC is stored in the all-wheel drive control module, J492 (address word 0022):

- **DTC C111204** (All Wheel Drive clutch pump faulty)

## Technical Background

There is an internal leak in the hydraulic pump.

## Production Solution

Improved hydraulic pump.



# Technical Service Bulletin

## Service

1. Before proceeding, confirm that the issue matches the *Condition* exactly.
2. Confirm that the propeller shaft from the transmission to the differential is transmitting power to the rear differential.
3. Replace the BorgWarner clutch pump according to the Elsa Repair Manual.
4. Replace the high performance oil for the BorgWarner clutch according to the Elsa Repair Manual.
5. Perform all-wheel drive basic settings.

**Note:**

The final drive and the BorgWarner clutch have separate oil circuits. Refer to ETKA for information on which oil to use, and refer to the Elsa Repair Manual for draining and filling information.

- The BorgWarner Clutch uses high performance oil for clutches, and the final drive uses gear oil.
- The image at right (Figure 1) shows the correct drain and fill plugs.

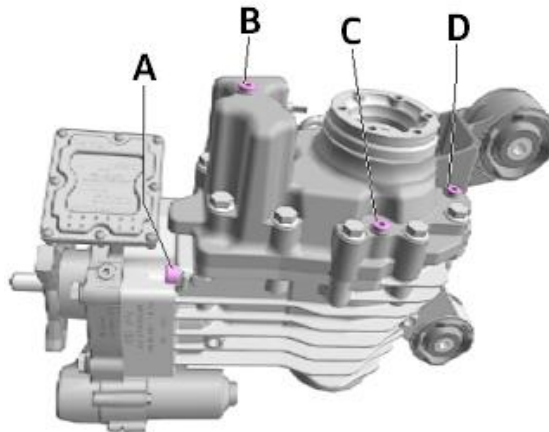

**Figure 1.** Drain plug for BorgWarner clutch oil (A), oil filler plug for BorgWarner clutch oil (B), gear oil drain plug (C), oil filler plug for gear oil (D).

## Warranty

<b>Claim Type:</b>	<ul style="list-style-type: none"><li>• 110 up to 48 Months/50,000 Miles.</li><li>• G10 for CPO Covered Vehicles – Verify Owner.</li><li>• If vehicle is outside any warranty, this Technical Service Bulletin is informational only.</li></ul>		
<b>Service Number:</b>	3994		
<b>Damage Code:</b>	0040		
<b>Labor Operations:</b>	Pump for AWD remove + reinstall	3994 1900	90 TU



# Technical Service Bulletin

<b>Diagnostic Time:</b>	GFF	0150 0000	Time stated on diagnostic protocol (Max 70 TU)
	Road test prior to service procedure	0121 0002	10 TU
	Road test after service procedure	0121 0004	10 TU
	Technical diagnosis at dealer's discretion (Refer to Section 2.2.1.2 and Audi Warranty Online for DADP allowance details)		
<b>Claim Comment:</b>	As per TSB #2043144/3		

All warranty claims submitted for payment must be in accordance with the *Audi Warranty Policies and Procedures Manual*. Claims are subject to review or audit by Audi Warranty.

## Required Parts and Tools

Part Number	Part Description	Quantity
0CQ598549	Repair kit for primer pump	1
G 060175A2	High performance oil for all wheel drive coupling	1
N 90281802	Seal bolt	1
N 10720201	Bolt with polygon socket head	1
N 91082701	Bolt with hex socket head	1

## Additional Information

All parts and service references provided in this TSB (2043144) are subject to change and/or removal. Always check with your Parts Department and service manuals for the latest information.

©2017 Audi of America, Inc. All rights reserved. Information contained in this document is based on the latest information available at the time of printing and is subject to the copyright and other intellectual property rights of Audi of America, Inc., its affiliated companies and its licensors. All rights are reserved to make changes at any time without notice. No part of this document may be reproduced, stored in a retrieval system, or transmitted in any form or by any means, electronic, mechanical, photocopying, recording, or otherwise, nor may these materials be modified or reposted to other sites without the prior expressed written permission of the publisher.