



Jason Guidi

Director - Regulatory & Compliance

June 08, 2017

Subject: Recall R89716

TO: All U.S. and Canadian Volvo Retailers

VEHICLES in RETAILER INVENTORY

It is a violation of federal law for a retailer to deliver any new Volvo that is eligible for a recall. Retailers are advised to check all vehicles in inventory for recall eligibility and repair immediately. Violation of this requirement by a retailer could result in a civil penalty of up to \$21,000 per vehicle.

Correct all vehicles in your new vehicle inventory before delivery.

Volvo Car USA LLC and Volvo Car Canada LTD (Volvo) on behalf of Volvo Car Group has decided to launch Recall R89716 on certain model year 2017 XC90 vehicles.

The crimping of the tube for the Micro Gas Generator (MGG) in the 3rd row passengers side seat belt retractor, was not manufactured to specification. In the event of a crash where the pre-tensioner is activated and in combination with certain conditions, the MGG squib may detach and be propelled out of the tube. If the MGG squib penetrates the inner side trim panel, it will lose most of its kinetic energy before it may enter the 3rd row occupant compartment. Despite this condition, the seat belt functions properly.

The corrective action is to replace the 3rd row passenger's side seatbelt retractor.

A total of 1,305 U.S. and 101 Canadian vehicles are eligible for this recall.

Vehicle eligibility must be confirmed:

- Vehicle Inquiry – Vehicle Warranty where the message "Recall R89716 Replace 3rd Row Seatbelt Retractor" will appear for eligible vehicles.
- All cars not yet delivered to end customers must be corrected prior to delivery.



- There have been no reports of incidents related to this issue.
- If you have any questions concerning this recall send them to recall@volvocars.com.

OWNER NOTIFICATION

Owner notification letters will be mailed in August. Owners of eligible retailed vehicles that are requesting this recall to be performed should be accommodated.

PORT VEHICLES

No vehicles will be shipped from the ports with this recall not completed.

PARTS / PARTS RETURN

No replacement parts are available at this time. We will be updating this communication and the Parts Bulletin as parts shipment information becomes available.

CLAIM SUBMISSION

Please refer to the claim submission information in the attached Quality Bulletin.

RETAILER RESPONSIBILITIES

Retailers must perform this recall campaign on eligible vehicles regardless of miles/kilometers or vehicle age. All work performed under this recall is free of charge to the owner.

As the safety of our customers is our utmost priority, we are taking full responsibility to ensure the highest quality and safety standards for our cars.

If you have questions about this recall or any other field service action, please contact me or any member of the Product Safety and Compliance office.

Your cooperation in completing this important recall is greatly appreciated.

Drive Safely,

A handwritten signature in black ink that reads "Jason Guidi".

Jason Guidi
Director - Regulatory & Compliance
201-768-7300
jason.guidi@volvocars.com

VOLVO CAR SERVICE AND PARTS BUSINESS				
<h1>Quality Bulletin</h1>				
TITLE: Recall R89716: Replace 3rd Row Passengers Side Seatbelt Retractor Model Year 2017, Model XC90 with 7 Seats				
GROUP:	CAT/NO: R89716	ISSUING DEPARTMENT: Warranty		CAR MARKET: United States and Canada
REFERENCE BULLETINS: TJ 32813			ISSUE DATE: 2017-06-08	STATUS DATE: 2017-06-08
Service Personnel: Read and initial	SERVICE MANAGER	SERVICE WRITER	WARRANTY ADMINISTRATOR	
			Page 1 of 3	

“Right first time in Time”

- A. RECALL R89716 DESCRIPTION
- B. VEHICLES INVOLVED
- C. PARTS INFORMATION/PARTS RETURN
- D. OWNER NOTIFICATION
- E. VEHICLES IN RETAILER INVENTORY
- F. RETAILER RESPONSIBILITY
- G. CAMPAIGN REIMBURSEMENT PROCEDURES
- H. TECHNICIAN COMPETENCY REQUIREMENT
- I. RETAILER ALLOWANCE

A. RECALL R89716 DESCRIPTION

Volvo Car USA LLC and Volvo Car Canada LTD (Volvo) on behalf of Volvo Car Group has decided to launch Recall R89716 on certain model year 2017 XC90 vehicles with 7 seats.

The crimping of the tube for the Micro Gas Generator (MGG) in the 3rd row passengers side seat belt retractor, was not manufactured to specification. In the event of a crash where the pretensioner is activated and in combination with certain conditions, the MGG squib may detach and be propelled out of the tube. If the MGG squib penetrates the inner side trim panel, it will lose most of its kinetic energy before it may enter the 3rd row occupant compartment.

Despite this condition, the seat belt functions properly.

The corrective action is to replace the 3rd row passenger’s side seatbelt retractor.

A total of 1,305 U.S. and 101 Canadian vehicles are eligible for this recall.



B. VEHICLES INVOLVED

NOTE: RETAILER MUST CONFIRM VEHICLE ELIGIBILITY PRIOR TO BEGINNING THE REPAIR FOR THIS RECALL.

Vehicle eligibility must be confirmed:

- Vehicle Inquiry – Vehicle Warranty where the message “Recall R89716 Replace 3rd Row Seatbelt Retractor” will appear for eligible vehicles or check eligibility in TIE.

All vehicles should be checked for any incomplete recalls or service campaigns or service upgrades. All open Recall, Service Campaign or Service Action repairs should be completed. If you have any questions concerning this recall send them to recall@volvocars.com.

C. PARTS / PARTS RETURN

No replacement parts are available at this time.

Please refer to Parts Bulletin 88-R89716 for updates.

Replaced parts are required to be returned to Technical Material Analysis for this recall.

PORT VEHICLES

No vehicles will be delivered from the ports without having this recall performed.

All vehicles must be checked for any incomplete recalls or service campaigns or service upgrades prior to delivery.

D. OWNER NOTIFICATION

Owner notification letters will be mailed in August. Owners of eligible retailed vehicles that are requesting this recall to be performed should be accommodated.

E. VEHICLES IN RETAILER INVENTORY

It is a violation of federal law for a retailer to deliver any new Volvo that is eligible for a recall. Retailers are advised to check all vehicles in inventory for recall eligibility and repair immediately. Violation of this requirement by a retailer could result in a civil penalty of up to \$21,000 per vehicle. Correct all vehicles in your new vehicle inventory before delivery.

F. RETAILER RESPONSIBILITY

All vehicles qualifying for this recall must be repaired prior to a customer taking possession of the vehicle.

G. CAMPAIGN REIMBURSEMENT PROCEDURES

Recall R89716 claims should be submitted using the LONG FORM application only.

H. TECHNICIAN COMPETENCY REQUIREMENT

The technician competency requirement for this campaign repair is: Level 2 – Certified Tech.



Quality Bulletin R89716

I. RETAILER ALLOWANCE (LONG FORM APPLICATION)

Claim Type: R89716
Cause Code: 02
CSC Code: XW
Main OP: 97195
Failed Part: 39825742, 39842894

<u>Operation Number</u>	<u>Repair Description</u>	<u>Qty</u>	<u>Labor Time</u>
97195	Replace 3rd Row Seatbelt Retractor	1	0.6 Hr



Technical Journal

TITLE:

Recall R89716: Replace 3rd Row Passengers Side Seatbelt Retractor

REF NO: TJ 32813.1.1	ISSUING DEPARTMENT: Technical Service	CAR MARKET: United States and Canada	
PARTNER: 3 US 7510 Volvo Car USA		ISSUE DATE: 2017-06-08	STATUS DATE: 2017-06-08
FUNC GROUP: 8800	FUNC DESC: Interior equipment	Page 1 of 11	

“Right first time in Time”

Attachment

File Name	File Size
QBI-504457-1_1_0_en-US.pdf	3.5869 MB

Vehicle Type

Type	Eng	Eng Desc	Sales	Body	Gear	Steer	Model Year	Plant	Chassis range	Struc Week Range
256							2017-2017		-	0-0

CSC Customer Symptom Codes

Code	Description
XW	Service/repair/Service action/Recall

VST Operation Number

VST Operation Number	Description
97195	Replace 3rd Row Passenger Side Seatbelt Retractor

DTC Diagnostic Trouble Codes

Rows beginning with * are modified

Note! If using a printed copy of this Technical Journal, first check for the latest online version.

Text

**DESCRIPTION:**

Volvo Car USA LLC and Volvo Car Canada LTD (Volvo) on behalf of Volvo Car Group has decided to launch Recall R89716 on certain model year 2017 XC90 vehicles with 7 seats.

The crimping of the tube for the Micro Gas Generator (MGG) in the 3rd row passengers side seat belt retractor, was not manufactured to specification. In the event of a crash where the pre-tensioner is activated and in combination with certain conditions, the MGG squib may detach and be propelled out of the tube. If the MGG squib penetrates the inner side trim panel, it will lose most of its kinetic energy before it may enter the 3rd row occupant compartment.

Despite this condition, the seat belt functions properly.

SERVICE:

The corrective action is to replace the 3rd row passenger's side seatbelt retractor.

VEHICLE REPORT:

N/A

To view TJ attachment continue to next page. This TJ has one attachment.



Volvo Car Customer Service

QB Instruction VCC-504457-1

Title	Seat belt retractor, rear	Page	1 (9)
Action	Replacement	Operation number:	97195-2

Issue	Date	Reason
1	2017-05	First issue

Affected vehicles

Model year	Model
2017	XC90 (16-)

Materials

Materials	Qty.	Part No.	Notes
Seat belt	1.0	39825742	3:D Row, Charcoal, US/CDN, RH;
Seat belt	1.0	39842894	3:D Row, Blond, US/CDN, RH;

Special tools

Description	Part No.
Interior trim remover	981 4071

Orientation view

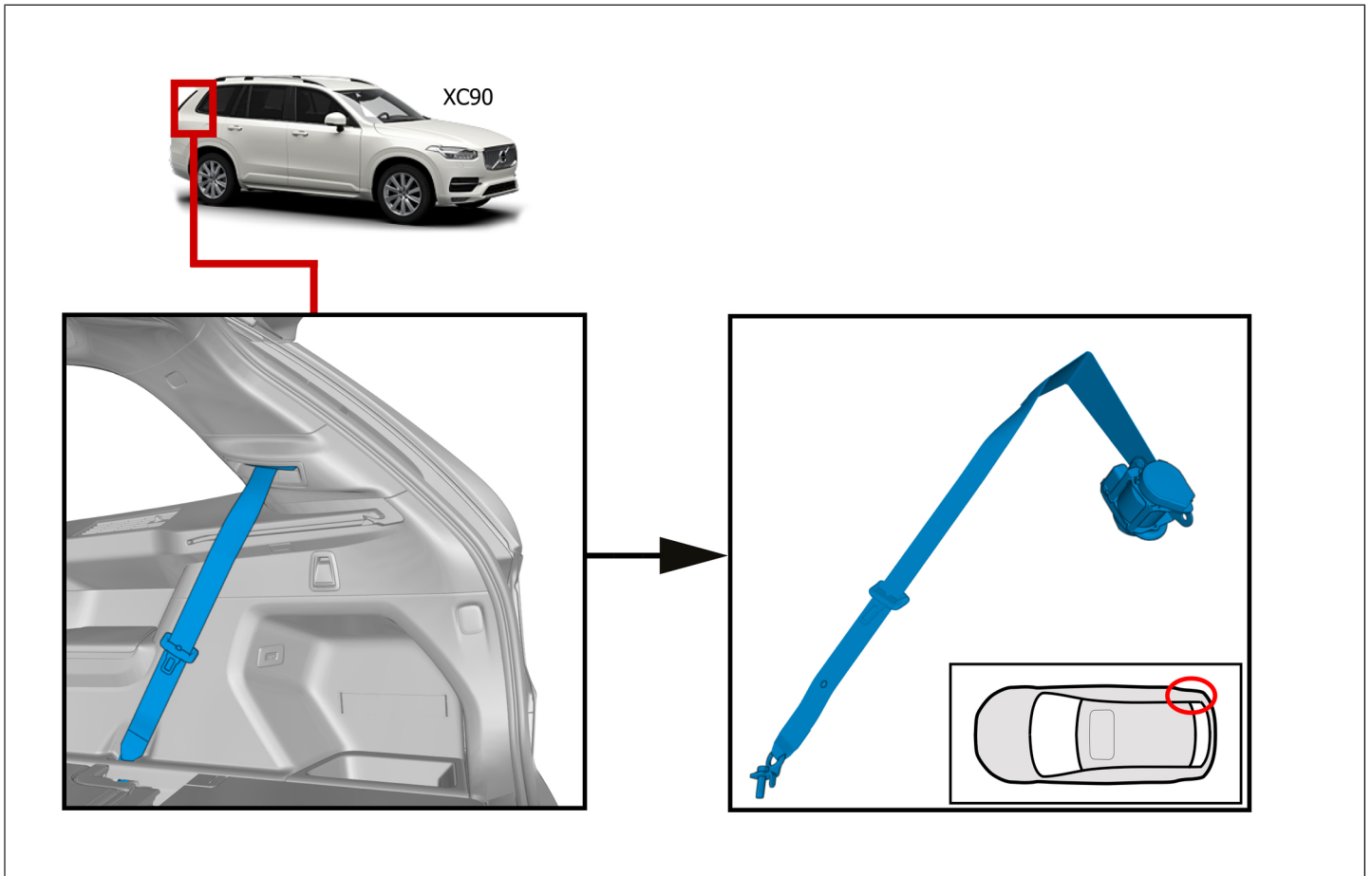

Color symbols

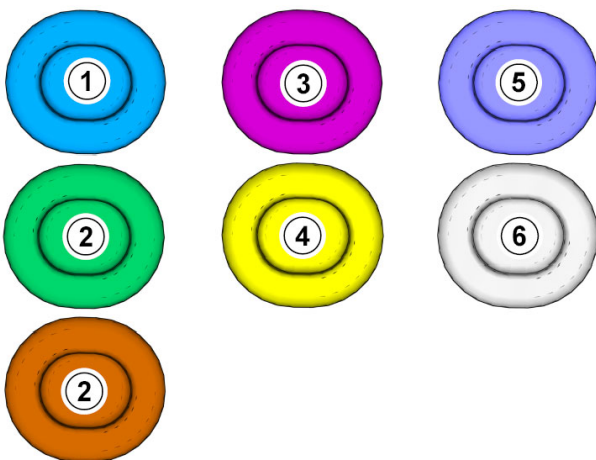

Note! This colour chart displays (in colour print and electronic version) the importance of the different colours used in the images of the method steps.

- 1 . Used for focused component, the component with which you will do something.
- 2 . Used as extra colors when you need to show or differentiate additional parts.
- 3 . Used for attachments that are to be removed/installed. May be screws, clips, connectors, etc.
- 4 . Used when the component is not fully removed from the vehicle but only hung to the side.
- 5 . Used for standard tools and special tools.
- 6 . Used as background color for vehicle components.

Removal

Note: Although some of the below images for interior panel removal show the left side of the vehicle, this action applies to the right side of the vehicle only.

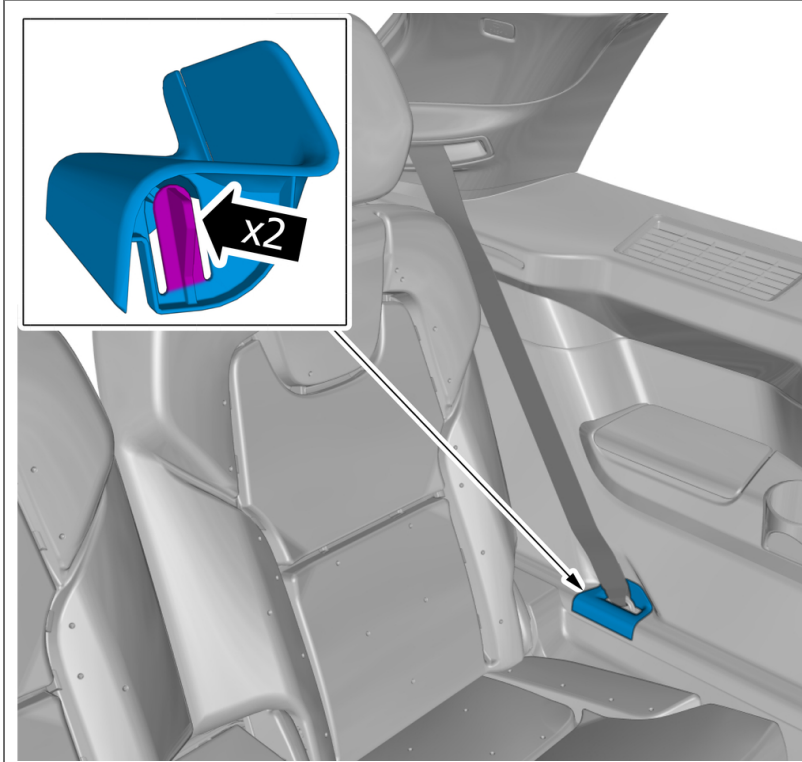

Right-hand side

Remove the marked part.

Special Tool: T9814071, Interior trim remover

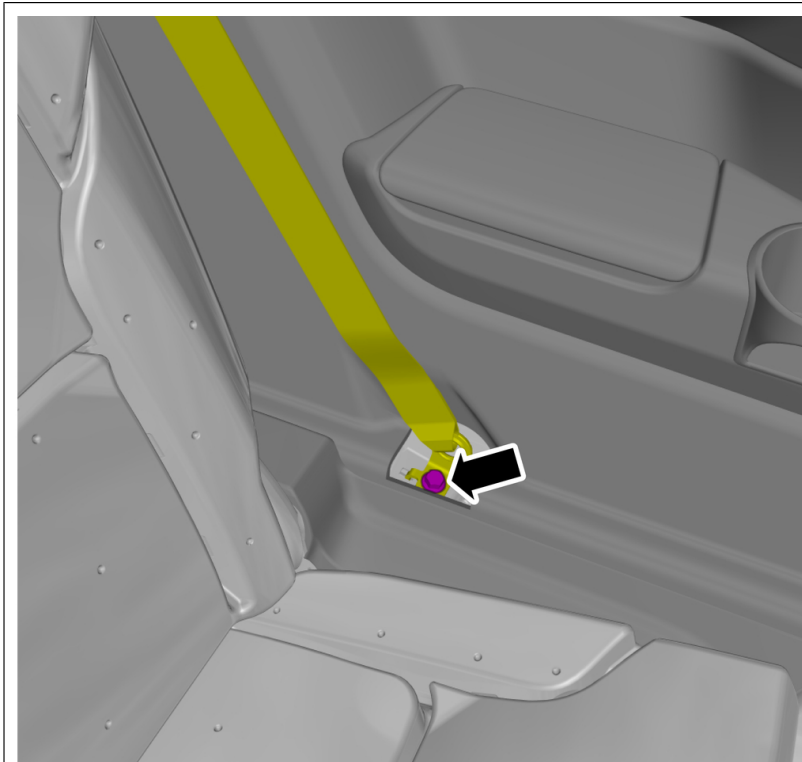

Right-hand side

Remove the screw.

Torque:

Safety belt lower anchor to body (rear) ,
40 Nm

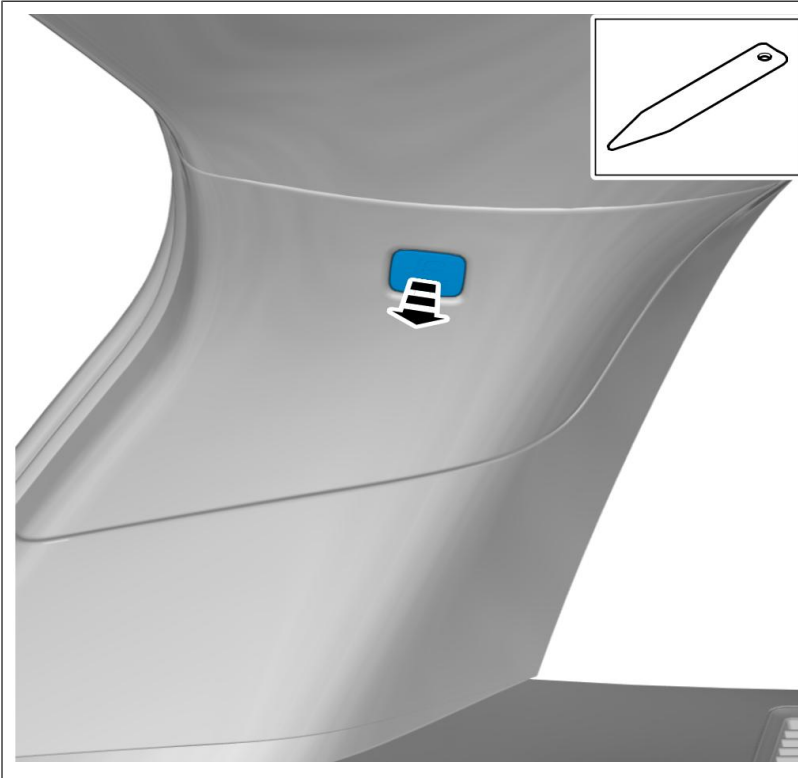

Right-hand side
Remove the marked part.

Special Tool: T9814071, Interior trim remover

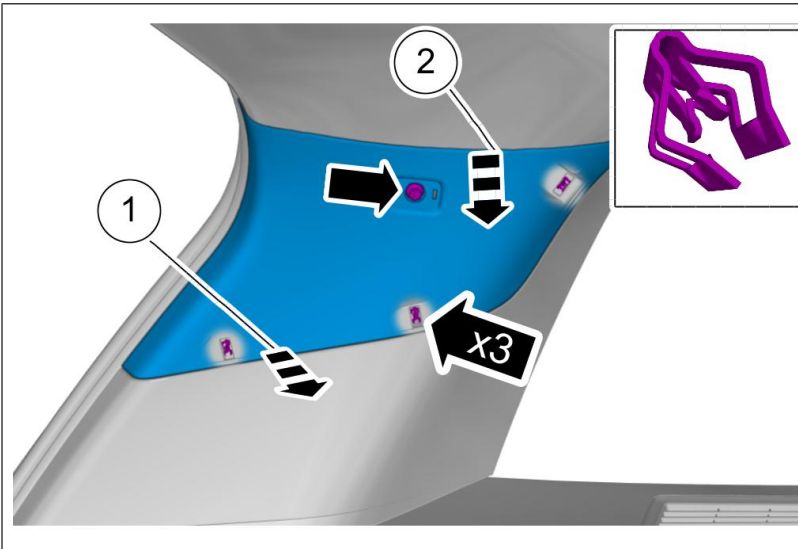

Right-hand side

1 . **Torque:**
Panel, to D-Pillar , 4.5 Nm

2 . Remove the screw.
3 . Remove the panel.

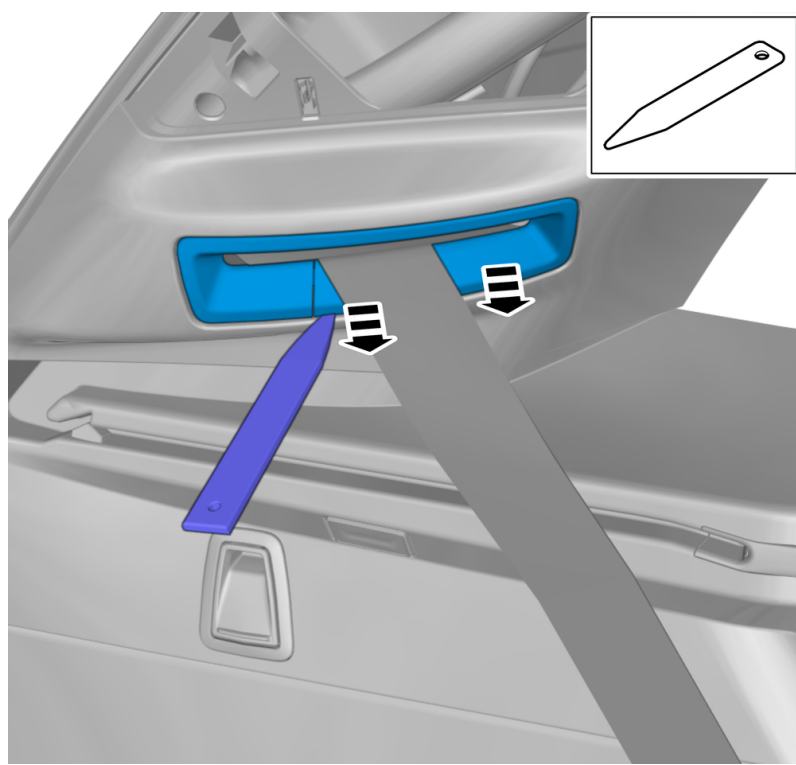

Right-hand side
Remove the marked part.
Special Tool: T9814071, Interior trim remover

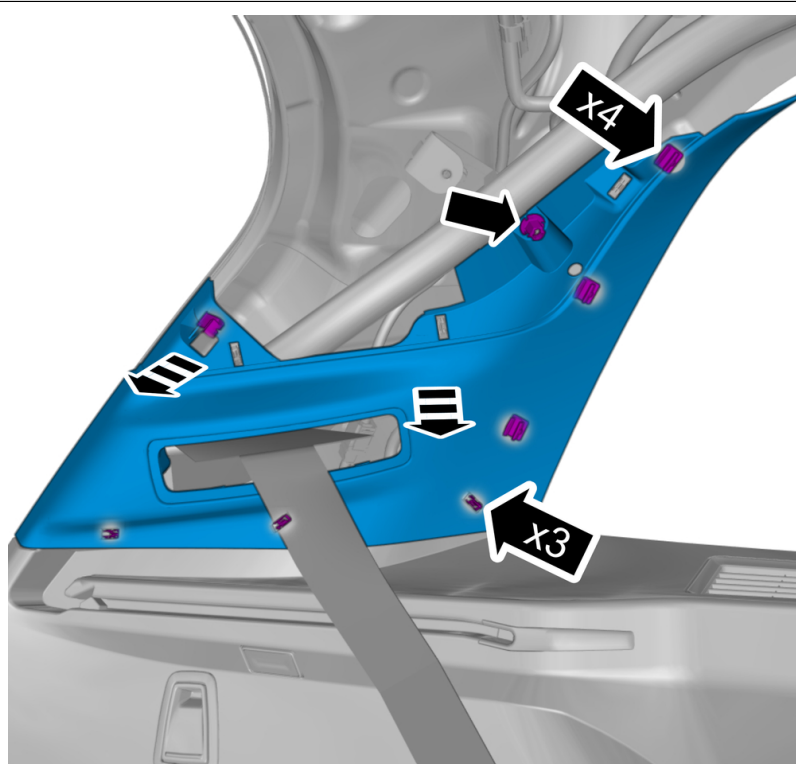

Right-hand side
Remove the nut.
Remove the marked part.

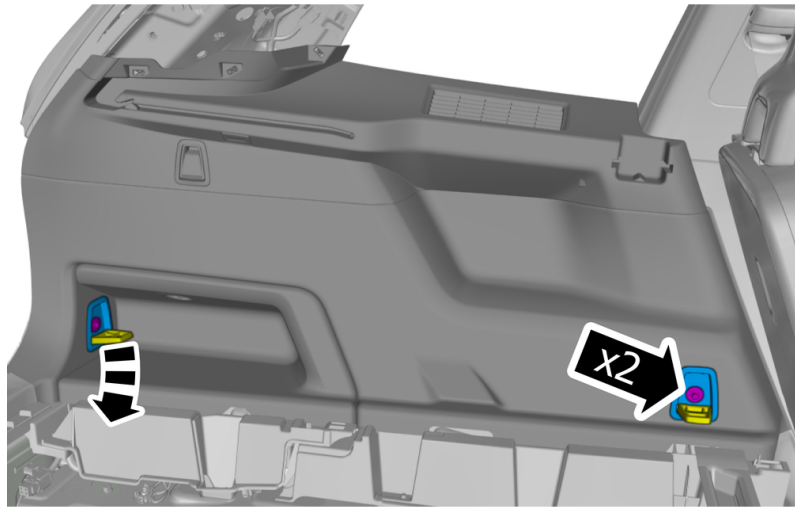

Right-hand side
Remove the screws.

Torque:

Cargo anchor, to body , 13 Nm

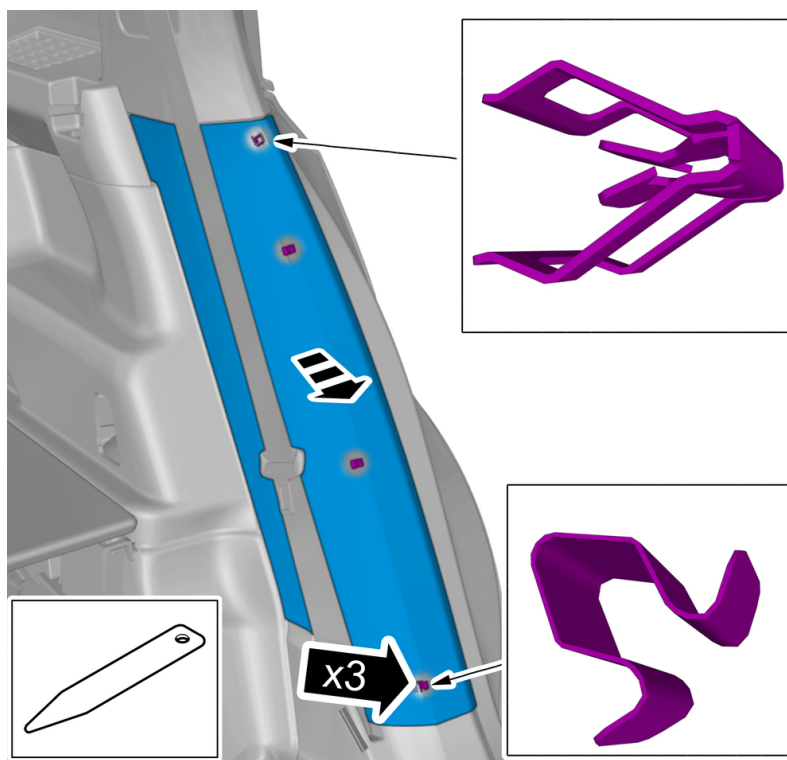

Right-hand side
Remove the panel.

Special Tool: T9814071, Interior trim remover

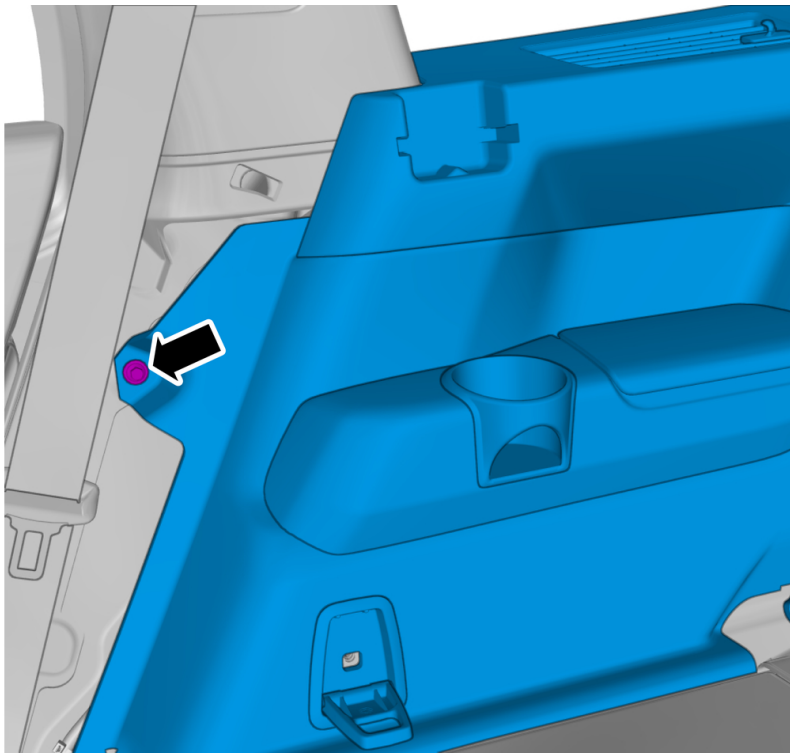

Right-hand side
Remove the screw.

Torque:

M5 , 5 Nm

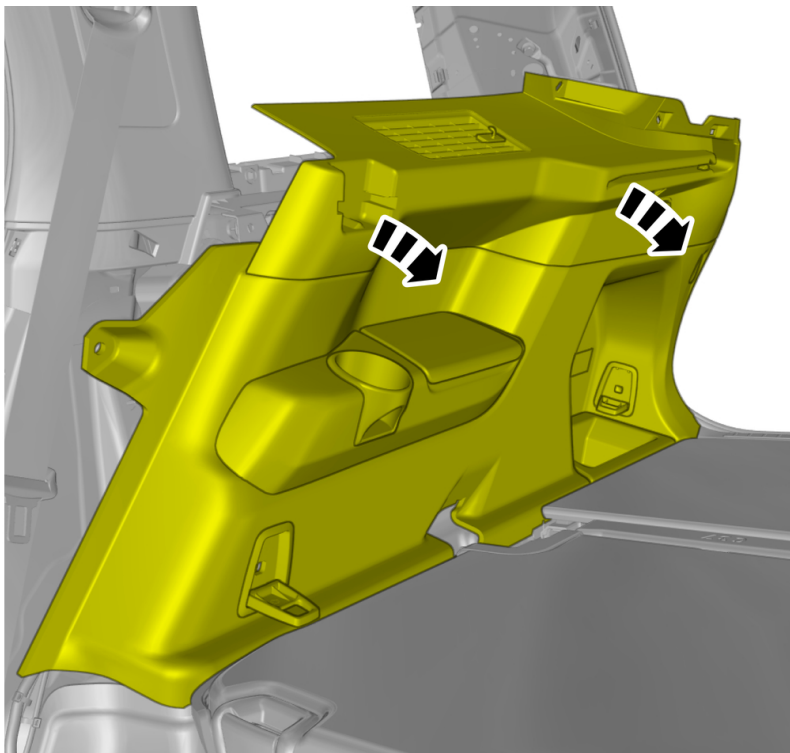

Right-hand side
Fold marked part to one side.

Disconnect connector ignition cable , refer to:
3 - Electrical system
37 - Cables and fuses
371 - cables

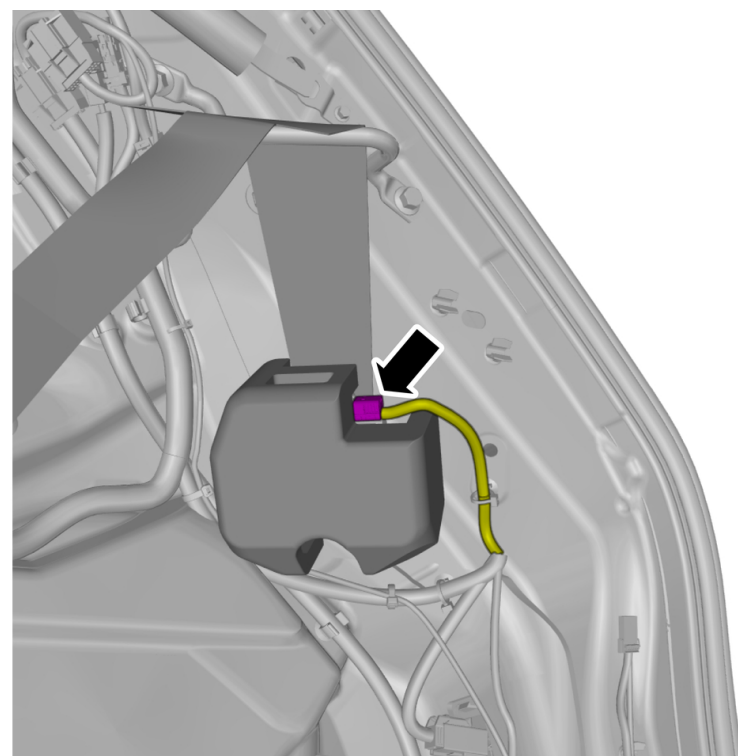

Right-hand side
Disconnect the connector.

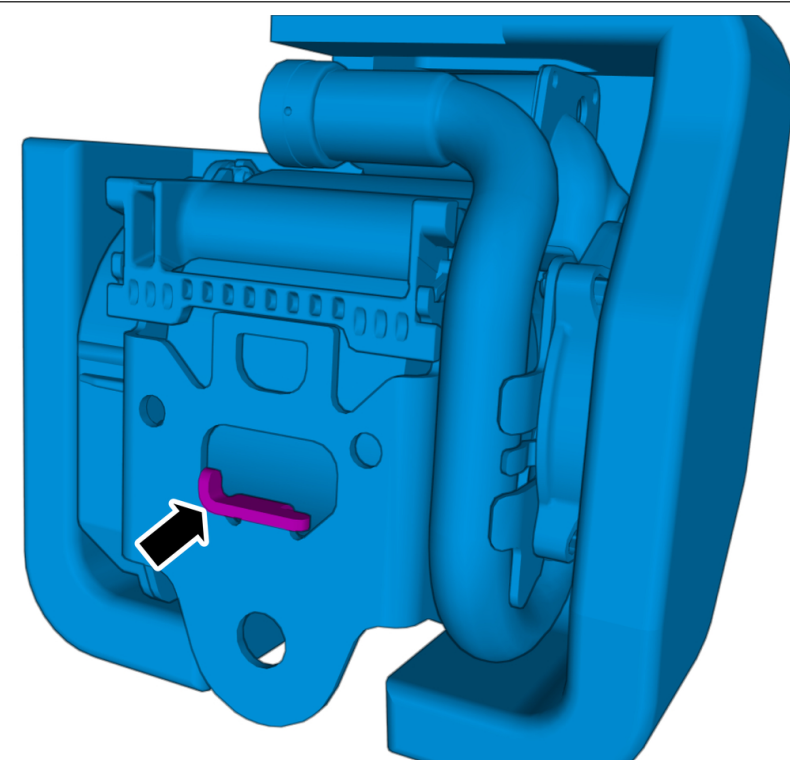

Note! The graphic shows the back of the component before removal.

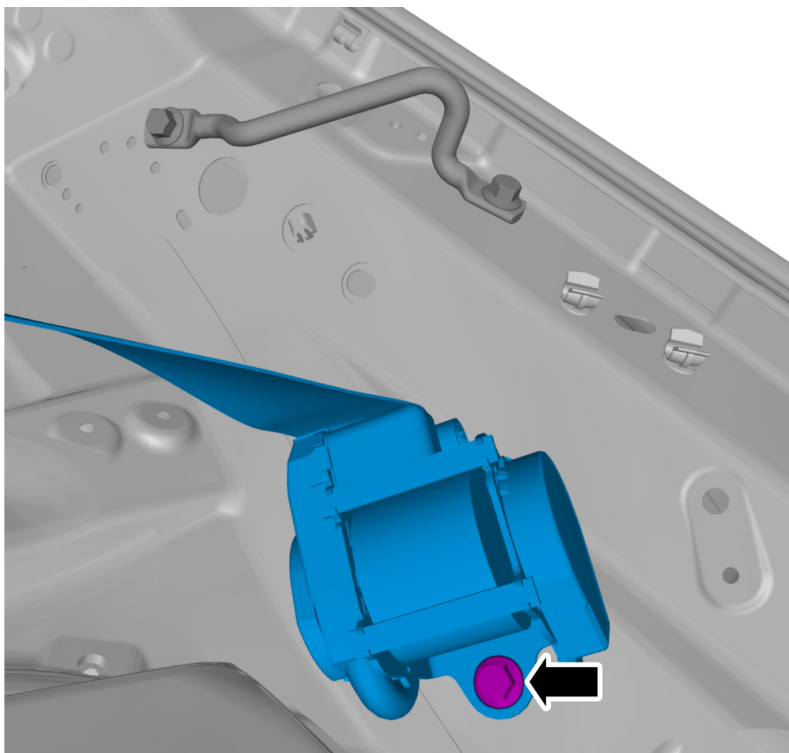

Right-hand side
Remove the screw.
Remove the marked part.

Torque:

Safety belt retractor rear to body , 40 Nm

Installation

To install, reverse the removal procedure.

Check that no diagnostic trouble codes (DTCs) are stored.



Parts Bulletin

TITLE:

**Recall R89716: Replace 3rd Row Passenger Side Seatbelt Retractor
Model Year 2017, XC90 with 7 Seats**

GROUP: 8	CAT/NO: R89716	REFERENCE BULLETINS: TJ 32813, QB R89716	CAR MARKET: United States and Canada	
COPY TO / CIRCULATIONS (PLEASE INITIAL):			ISSUE DATE: 2017-06-08	STATUS DATE: 2017-06-08
GENERAL MANAGER	PARTS MANAGER	SERVICE MANAGER	SALES MANAGER	
				Page 1 of 1

“Right first time in Time”

Reference Bulletins: TJ 32813, QB R89716

Volvo Car USA LLC and Volvo Car Canada LTD (Volvo) on behalf of Volvo Car Group has decided to launch Recall R89716 on certain model year 2017 XC90 vehicles with 7 seats.

The crimping of the tube for the Micro Gas Generator (MGG) in the 3rd row passengers side seat belt retractor, was not manufactured to specification. In the event of a crash where the pre-tensioner is activated and in combination with certain conditions, the MGG squib may detach and be propelled out of the tube. If the MGG squib penetrates the inner side trim panel, it will lose most of its kinetic energy before it may enter the 3rd row occupant compartment. Despite this condition, the seat belt functions properly.

The corrective action is to replace the 3rd row passenger’s side seatbelt retractor.

A total of 1,305 U.S. and 101 Canadian vehicles are eligible for this recall.

The following part numbers apply:

Part Number	Description	Qty
39842894	3rd Row seatbelt retractor (blond)	1
39825742	3rd Row seatbelt retractor (charcoal)	1

No replacement parts are available at this time. We will update this bulletin as soon as replacement parts information is available.