

This Field Service Bulletin replaces bulletin, "PV729-FSB293-022_V, EGR Temperature Sensor Routing", (USA61013) dated (08/2013).

EGR Temperature Sensor Routing
 VAH, VHD, VN
 D13H

FSB 293-022, EGR Temperature Sensor Routing

(March 2017)

Information

In the event that an EGR temperature sensor replacement is required on a VOLVO D13H engine, a new routing configuration is required. The new configuration requires seven cable ties (part number 948211) to secure the new 90-degree EGR temperature sensor and pigtail (part number 21164792) to the coolant pipe, around the venturi tube and along the main harness.

Service personnel: Please circulate, read and initial

Service Manager	Warranty Administrator	Workshop Foreman	Service Technicians						

Required Parts

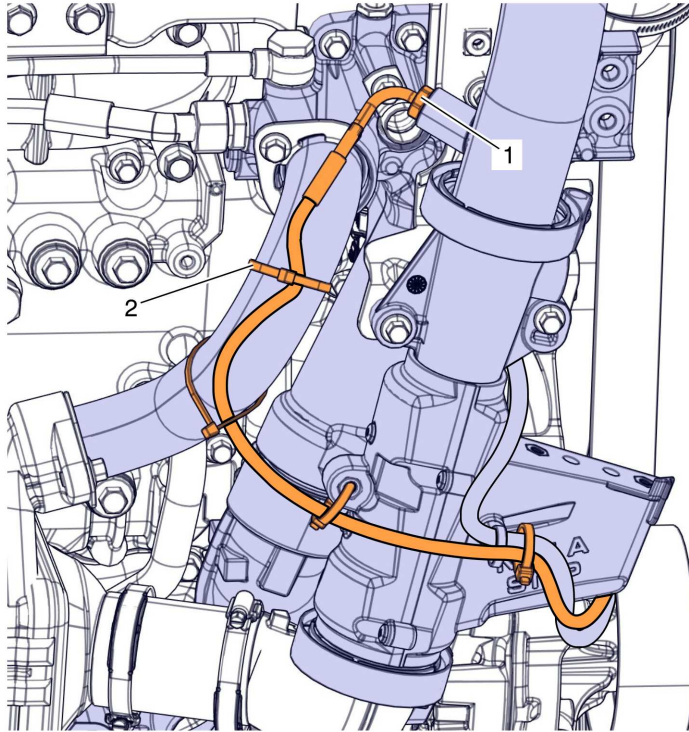

W2120801

EGR Temperature Sensor Routing Parts			
Item #	Description	Part Number	Qty
1	Temperature Sensor with Pigtail	21164792	1
2	Cable Tie	948211	7

Decommissioning the Truck for Repair

You must read and understand the precautions and guidelines in Service Information, group 20, "General Safety Practices, Engines" before performing this procedure. If you are not properly trained and certified in this procedure, ask your supervisor for training before you perform it.

NOTE: Information is subject to change without notice. Illustrations are used for reference only and can differ slightly from the actual vehicle being serviced. However, key components addressed in this information are represented as accurately as possible.



DANGER

Do not attempt to repair or service this vehicle without having sufficient training, the correct service literature and the proper tools. Failure to follow this could make the vehicle unsafe and lead to serious personal injury or death.

- 1 Park the vehicle on a level surface.
- 2 Apply the parking brake.
- 3 Place the transmission in neutral or park.
- 4 Install the wheel chocks on the rear wheels.

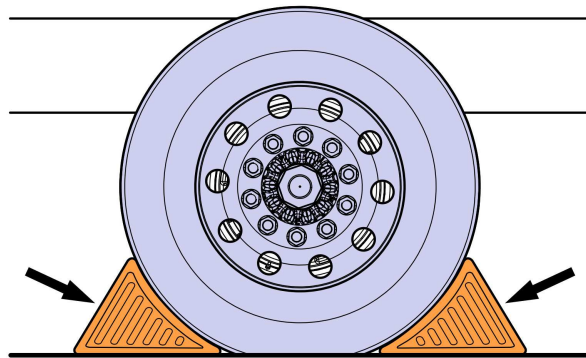

W7086748

- 5 Disconnect the cable from the battery's negative terminal.

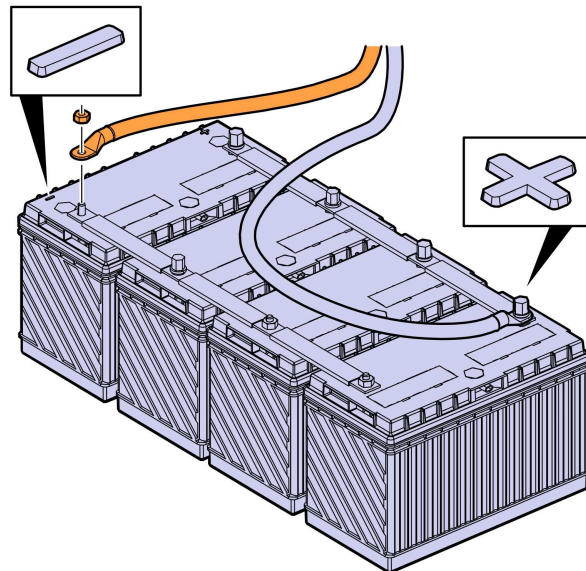

W3086747

EGR Temperature Sensor Routing Procedure

- 1 With 90-degree sensor installed, route pigtail down coolant pipe and secure with two cable ties.
- 2 Continue routing pigtail around venturi and follow EGR-dP sensor branch. Secure pigtail with two cable ties.
- 3 Secure one cable tie through venturi boss.
- 4 Secure one cable tie around EGR-dP branch and to the right of the push-in tie location.

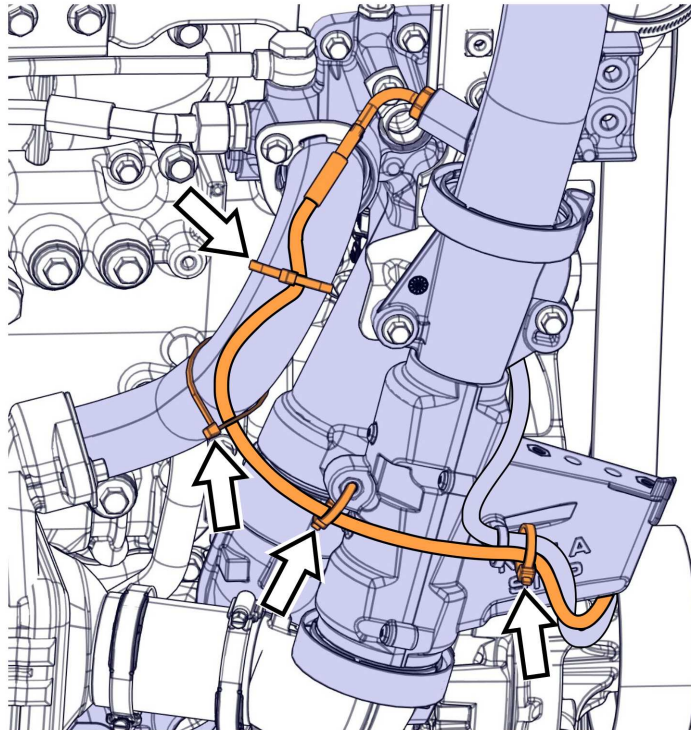

W2120802

- 5 Connect the sensor pigtail and harness connectors on top of main harness branch near coolant pump.
- 6 Route the temperature sensor branch along main harness and create loop to use one cable tie to secure branch only to main harness.
- 7 With connectors assembled together, secure assembly with two cable ties in their respective positions.
- 8 Use one cable tie to secure sensor pigtail and harness branch to main harness.
- 9 Use one cable tie to secure the connector assembly and harness branch to main harness.

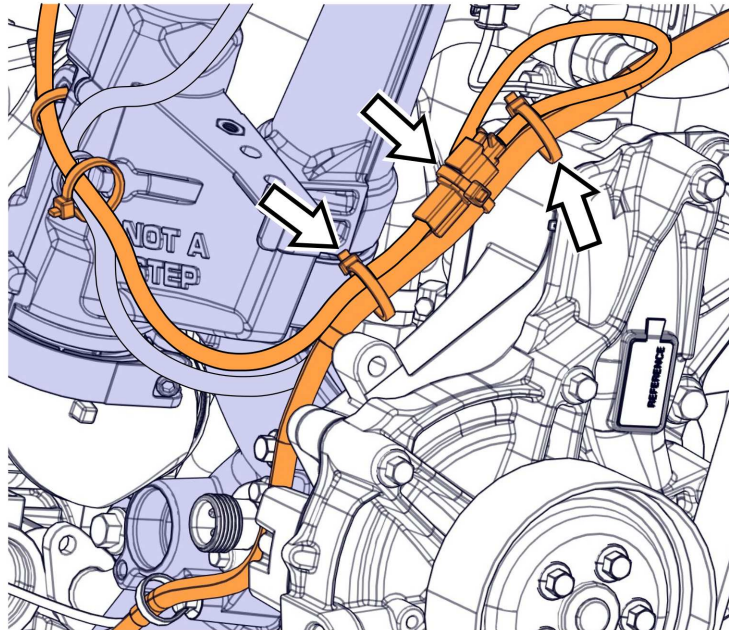

W2120803

Commissioning the Truck for Operation

- 1 Connect the cable to the battery's negative terminal.

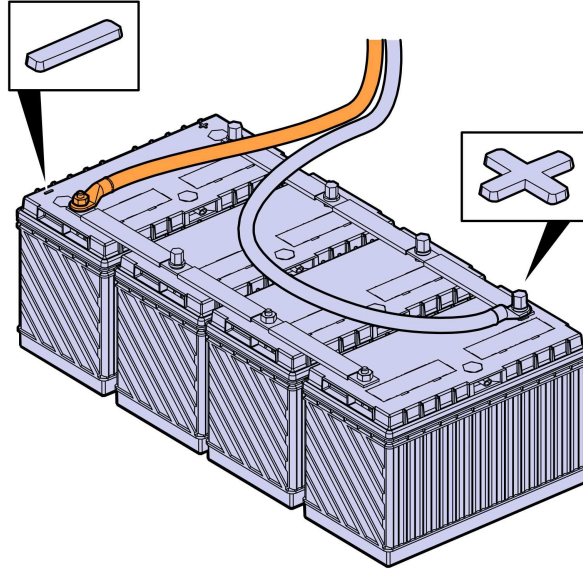

W3086758

- 2 Remove the wheel chocks from the rear wheels.

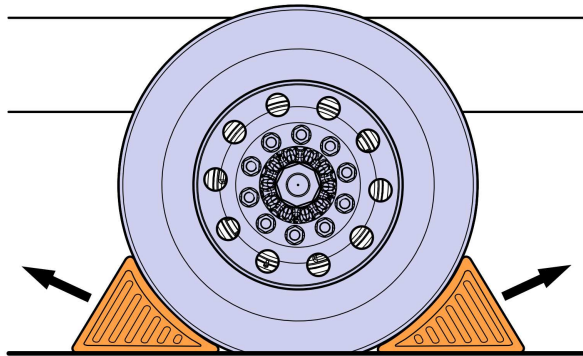

W7086759

Reimbursement

This repair may be eligible for reimbursement if a product failure was experienced within time and mileage limits of the applicable Warranty coverage. Reimbursement is obtained via the normal claim handling process.	UCHP Reimbursement
Claim Type (used only when uploading from the Dealer Bus. Sys.)	W
Labor Code	
Primary Labor Code (EGR Temperature Sensor Routing)	2939-03-02-02 0.4 hrs.
Causal Part	21164790

VOLVO Trucks North America reserves the right to make any changes in design or to make additions to or upon its products without incurring any obligations to install the same on vehicles previously built.