

JTBO0547NAS3

**TECHNICAL BULLETIN**

05 DEC 2017



© Jaguar Land Rover North America, LLC

NOTE: The information in Technical Bulletins is intended for use by trained, professional Technicians with the knowledge, tools, and equipment required to do the job properly and safely. It informs these Technicians of conditions that may occur on some vehicles, or provides information that could assist in proper vehicle service. The procedures should not be performed by 'do-it-yourselfers'. If you are not a Retailer, do not assume that a condition described affects your vehicle. Contact an authorized Jaguar service facility to determine whether this bulletin applies to a specific vehicle.

**INFORMATION**

---

This reissue replaces all previous versions. Please destroy all previous versions.

Changes are highlighted in blue

---

**SECTION:**

204-01: Front Suspension

---

**SUBJECT/CONCERN:**

Anti-lock Braking System Warning Lamp Illuminated in Instrument Cluster

---

**AFFECTED VEHICLE RANGE:**

<b>MODEL:</b>	<b>MODEL YEAR:</b>	<b>VIN:</b>	<b>ASSEMBLY PLANT:</b>	<b>APPLICABILITY:</b>
XE (X760)	2017	921222- 974047	Solihull	Vehicles With: 8HP45 8-Speed Automatic Transmission RWD

**MARKETS:**

NORTH AMERICA

**CONDITION SUMMARY:****SITUATION:**

The Anti-lock Brake System (ABS) warning light may be illuminated in the Instrument Cluster. Upon further inspection, Diagnostic Trouble Code (DTC) C0031-2F, C0031-29, C0031-31, C0031-62, C0034-2F, C0034-29, C0034-41, and/or C0034-62 may be stored in the Anti-lock Brake System Control Module

**CAUSE:**

This may be caused by water ingress through the wheel speed sensor mounting location.

**ACTION:**

Should a customer express this concern, follow the Workshop and Diagnostic Procedures below.

**PARTS:**

<b>PART NUMBER</b>	<b>DESCRIPTION</b>	<b>QUANTITY</b>
XR848057	Stabilizer bar link retaining nut - M10	2
T2H4069	Wheel Speed Sensor	2

**TOOLS:**

Jaguar Land  
Rover-approved  
Midtronics  
battery power  
supply



Jaguar Land  
Rover-approved  
diagnostic tool  
with latest SDD  
software,  
Calibration File



**JLR-  
204-  
842**  
Water Ingress Kit

**WARRANTY:****NOTES:**

- Repair procedures are under constant review, and therefore times are subject to change; those quoted here must be taken as guidance only. Always refer to JLR claims submission system to obtain the latest repair time.
- The JLR Claims Submission System requires the use of causal part numbers. Labor only claims must show the causal part number with a quantity of zero.

DESCRIPTION	SRO	TIME (HOURS)	CONDITION CODE	CAUSAL PART

DESCRIPTION	SRO	TIME (HOURS)	CONDITION CODE	CAUSAL PART
Wheel knuckle - Drain hole repair - Pair	60-25-80	1.10	42	T2H6337
Read and clear DTCs	86.99.78	0.2	42	T2H6337

**NOTE:**

Normal Warranty procedures apply.

**SERVICE INSTRUCTION:****NOTES:**

- Some components shown removed for clarity.
- Left-side shown; right-side similar.

1

**NOTE:**

Repeat this step to the other side of the vehicle.

Remove the front wheel arch liner (see TOPIx Workshop Manual section 501-02: Front End Body Panels - Fender Splash Shield).

2

**NOTE:**

Repeat this step to the other side of the vehicle.

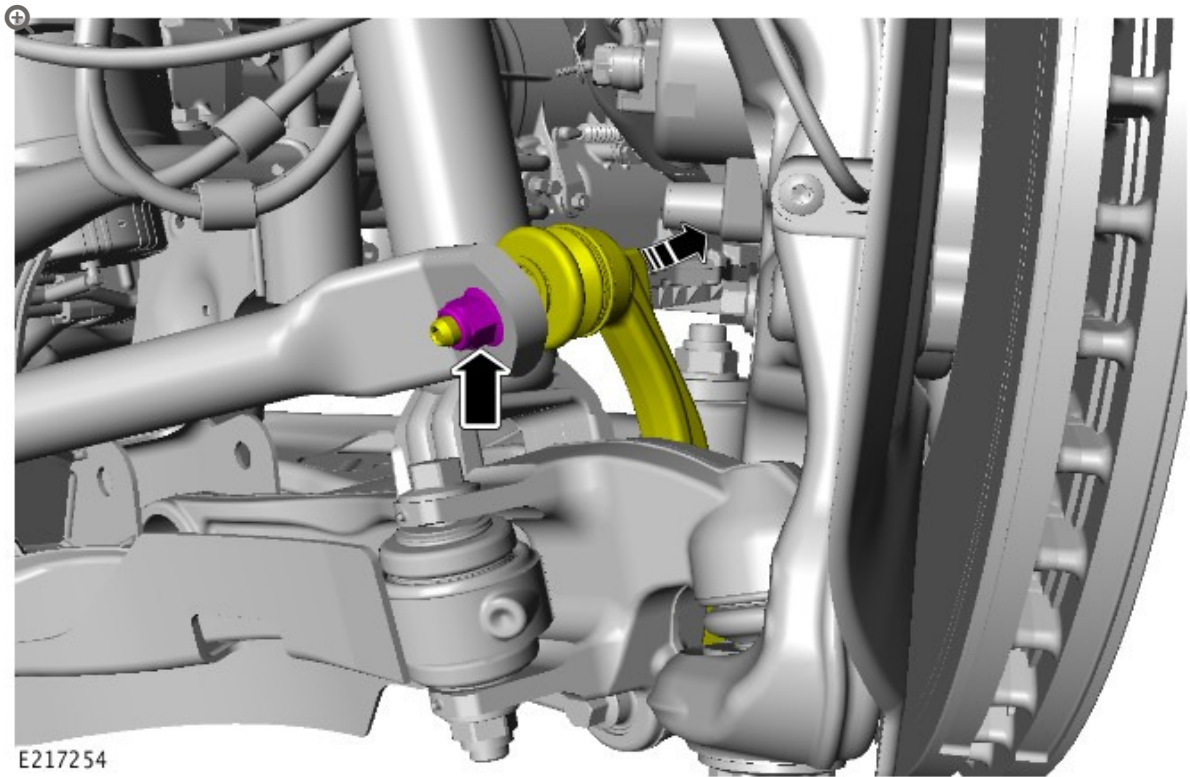

Remove and discard the nut from the front stabilizer bar link and position the front stabilizer bar link to one side.

---

3

**NOTE:**

Repeat this step to the other side of the vehicle.

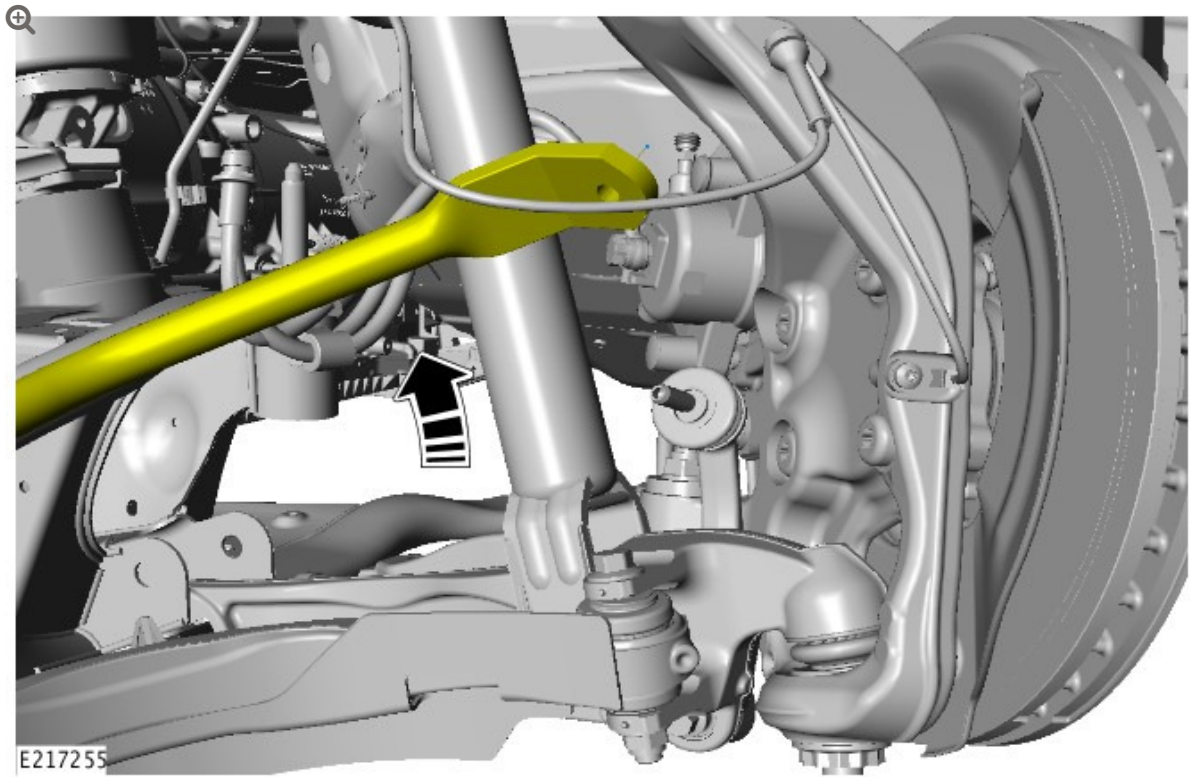

Raise the front stabilizer bar.

4

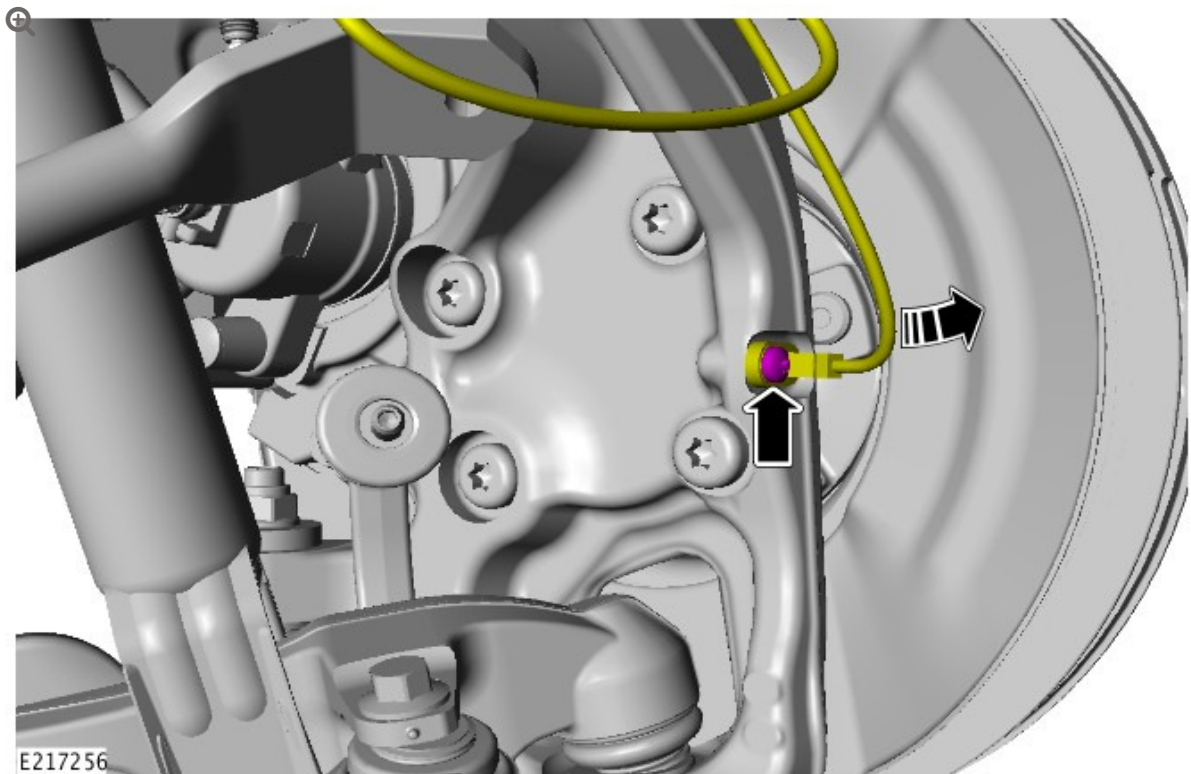

Remove the wheel speed sensor retaining bolt and place the wheel speed sensor to the side.

5

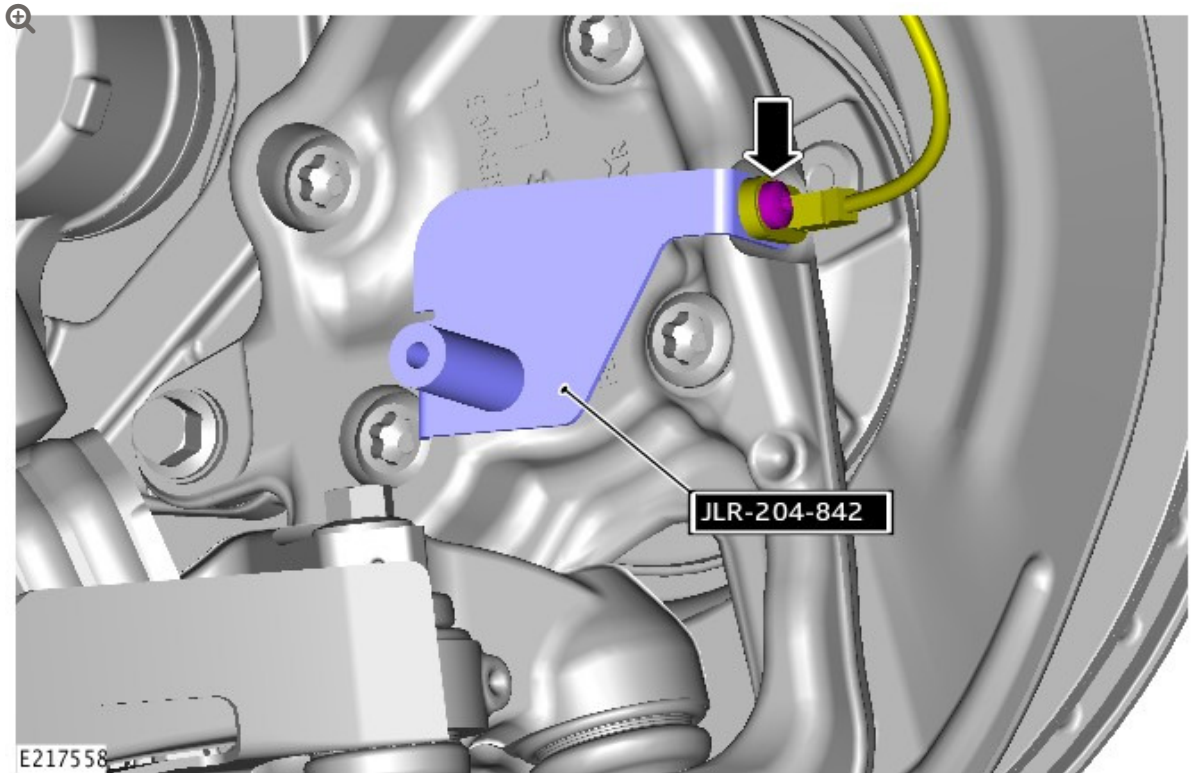

Using the wheel speed sensor install JLR-204-842 to the wheel knuckle.

6



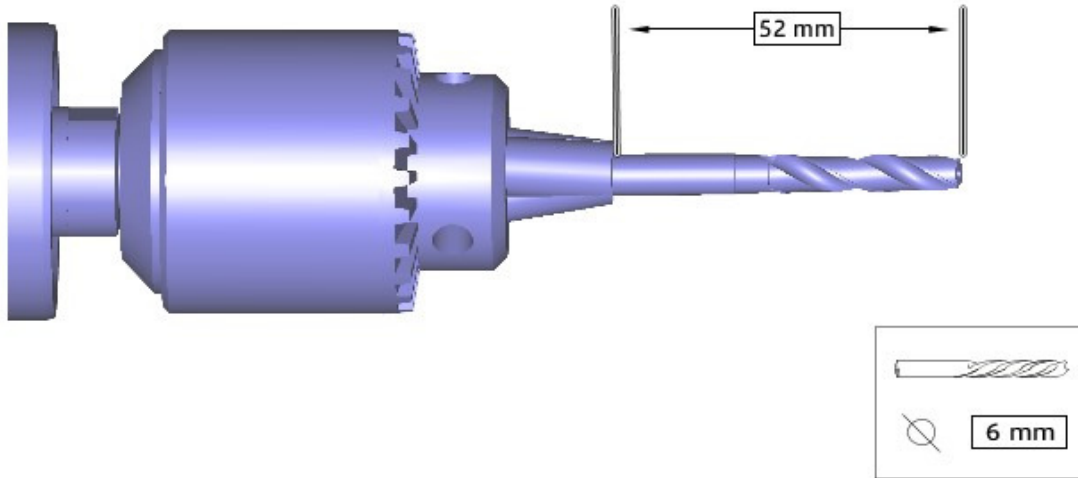

E217559

Install a 6 mm drill bit into the drill.

7

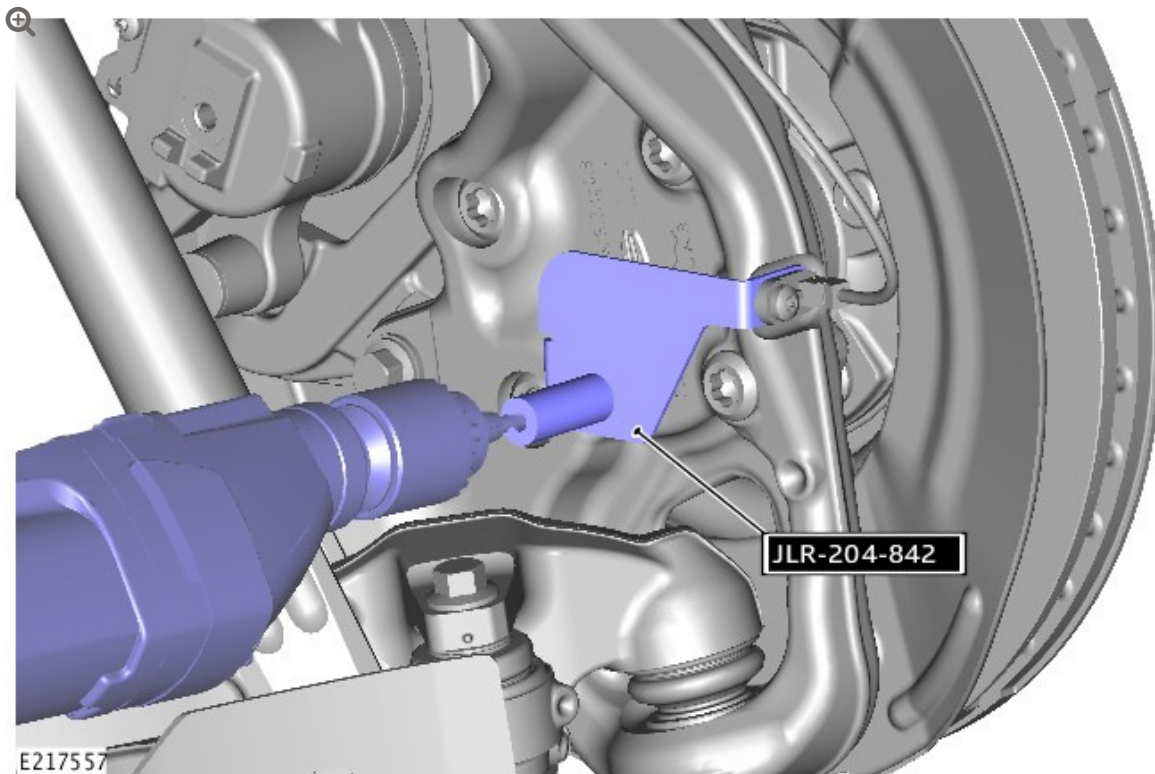



Using JLR-204-842 as a guide, drill a hole in the wheel knuckle.

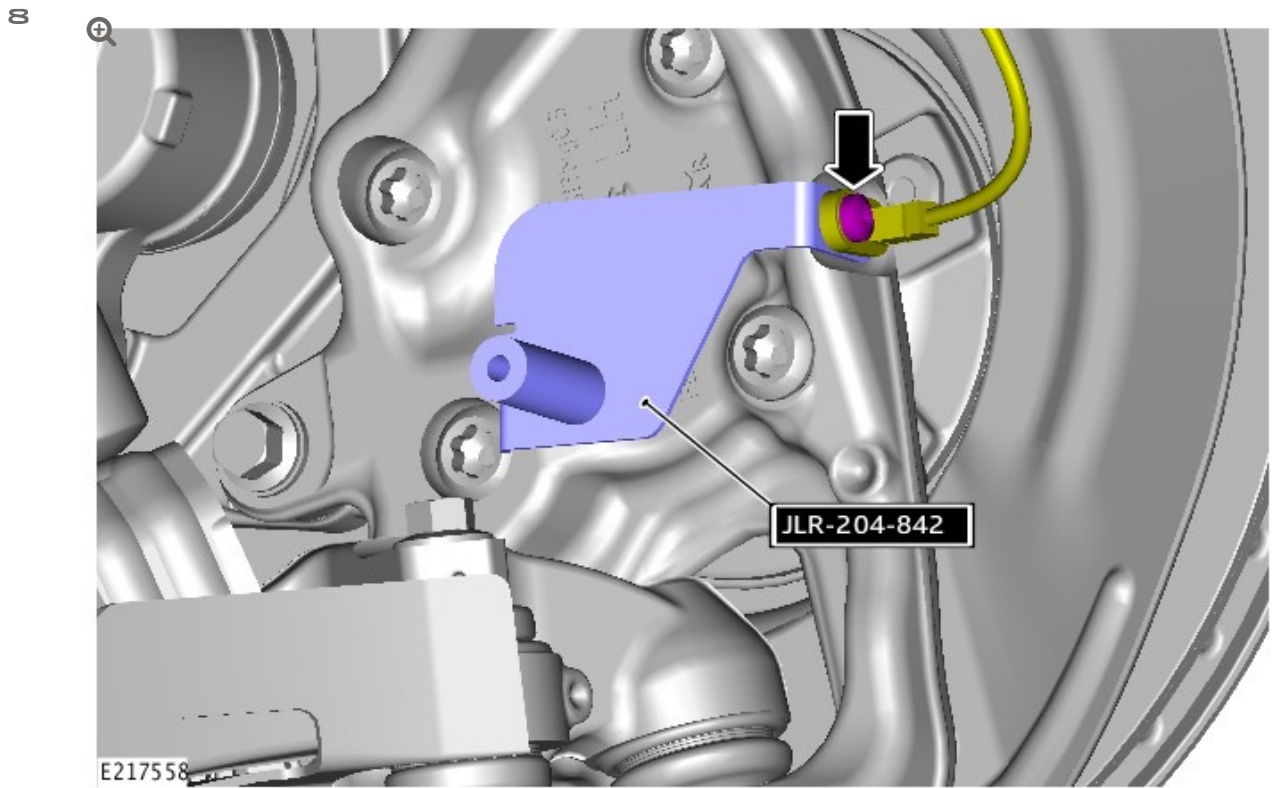

Remove the wheel speed sensor and JLR-204-842.

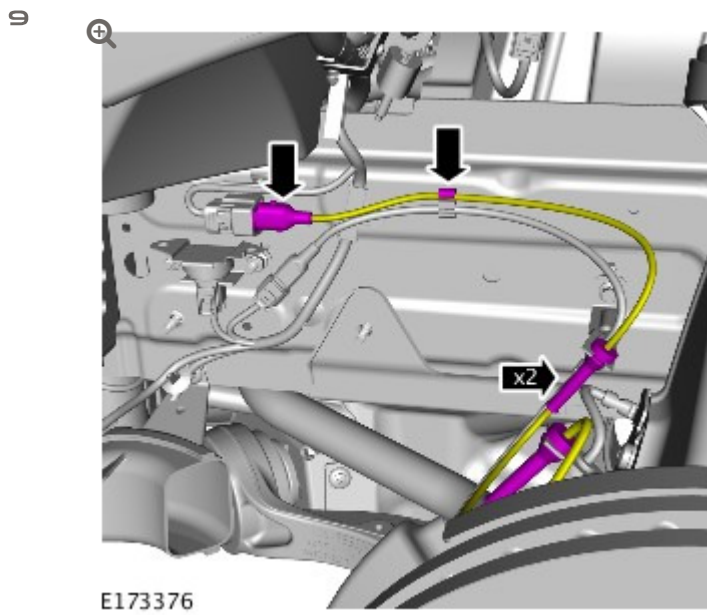

Remove and discard the wheel speed sensor.

10

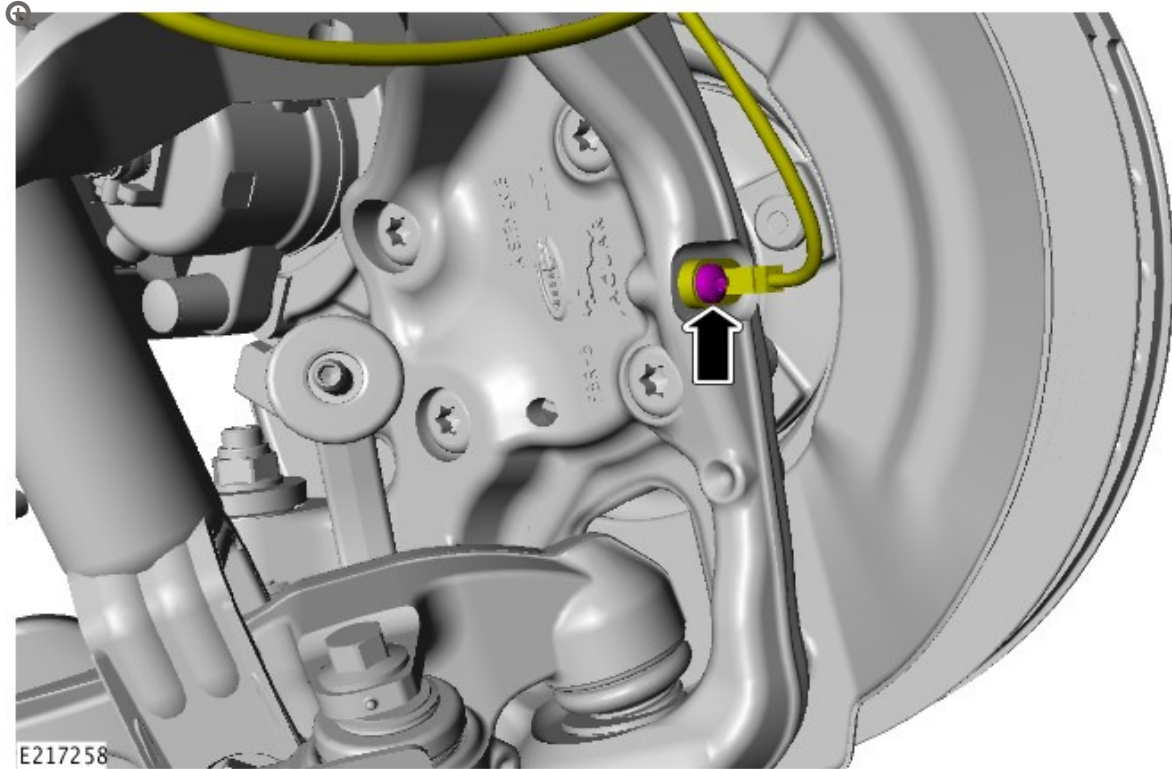

Install the new wheel speed sensor.

- Torque: **9 Nm**.

11

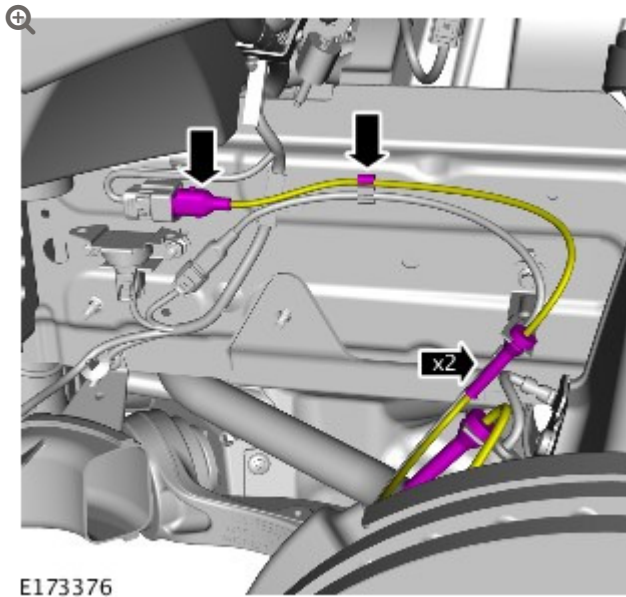

Connect the wheel speed sensor and secure in the location clips.

---

12 Repeat steps 4-11 for the front right wheel knuckle.

---

13

**NOTE:**

Repeat this step to the other side of the vehicle.

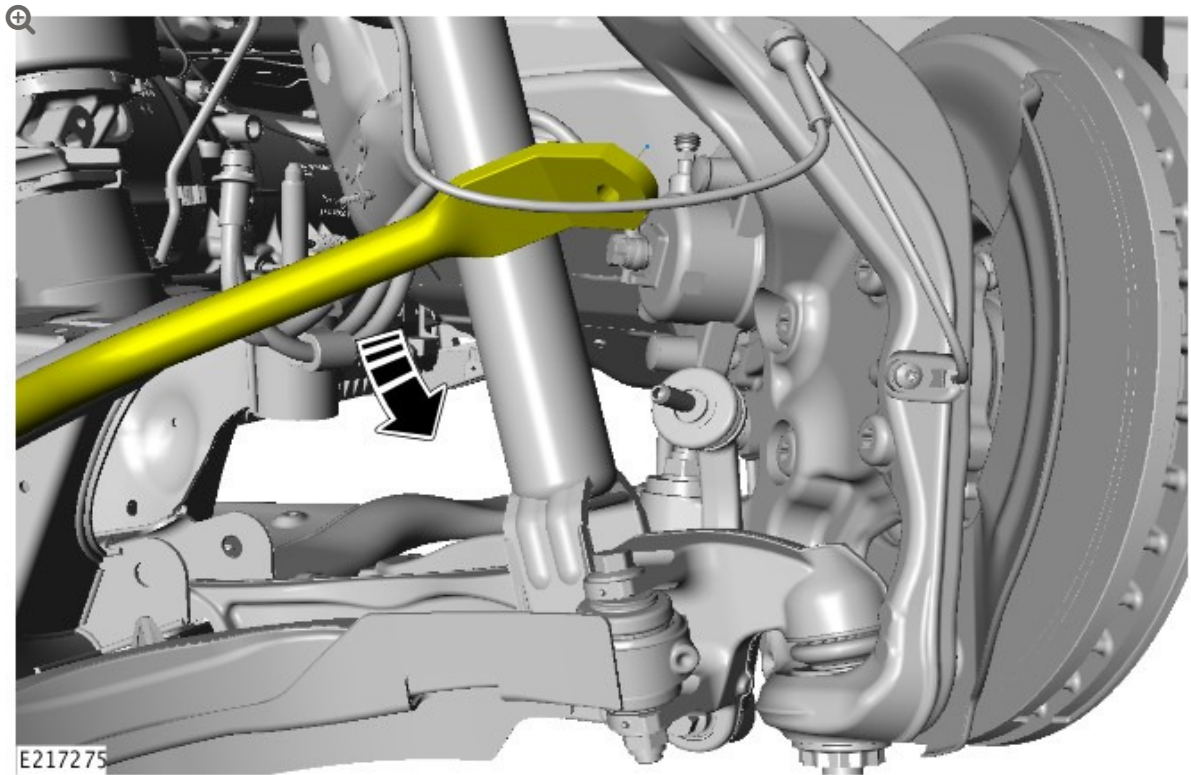

Lower the front stabilizer bar.

---

14

**NOTE:**

Repeat this step to the other side of the vehicle.

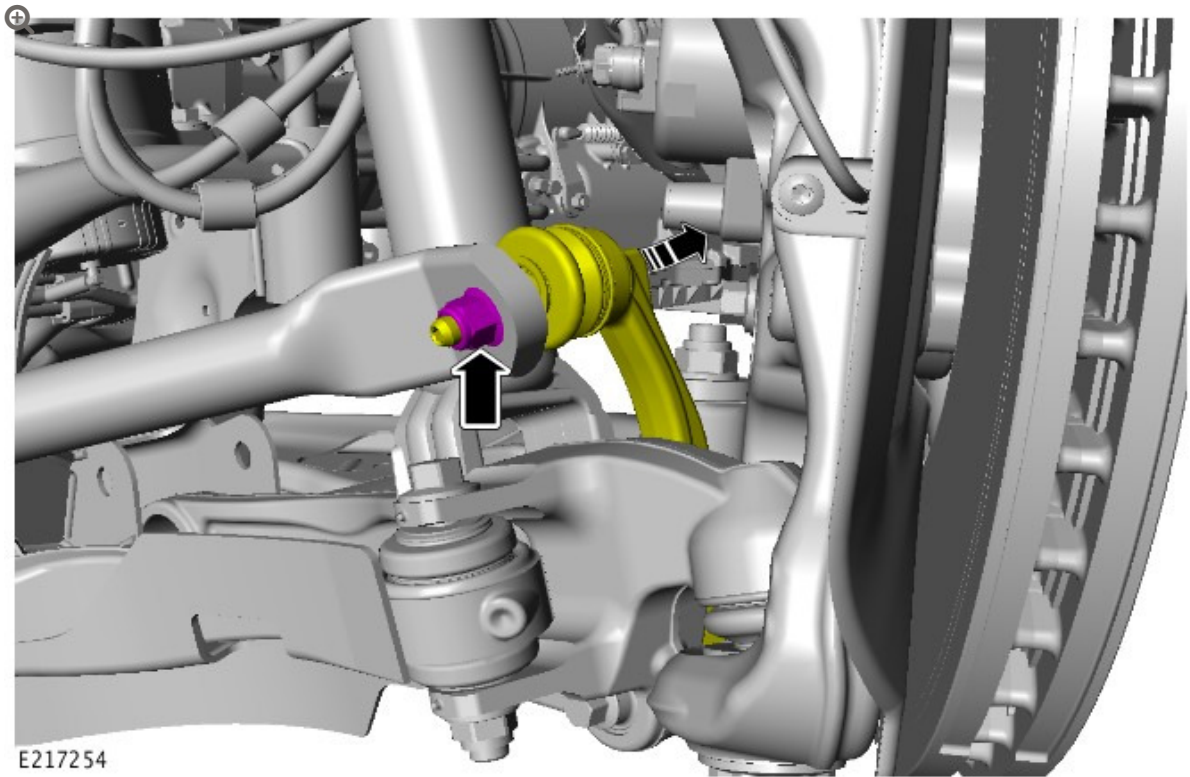

Using a new nut, install the front stabilizer bar link.

- Torque: **48 Nm**

---

15

**NOTE:**

Repeat this step to the other side of the vehicle.

Install the front wheel arch liner (see TOPIx Workshop Manual section 501-02: Front End Body Panels - Fender Splash Shield).

**DIAGNOSTIC PROCEDURE:**

---

**CAUTIONS:**

---

- A Jaguar Land Rover-approved Midtronics battery power supply must be connected to the vehicle battery during diagnosis / module programming.
- Make sure all ignition ON/OFF requests are carried out; failure to perform these steps may cause damage to control modules in the vehicle.

**NOTE:**

The Jaguar Land Rover-approved diagnostic tool must be loaded with DVD151.03 and Calibration File 281 (or later).

- 1 Connect the Jaguar Land Rover-approved Midtronics battery power supply to the vehicle battery.
- 2 Switch the ignition ON (engine not running).
- 3 Connect the Jaguar Land Rover-approved diagnostic tool to the vehicle and begin a new session.
- 4 Follow the on-screen prompts, allowing the diagnostic tool to read the VIN, identify the vehicle, and initiating the data collect sequence.
- 5 Read and clear all Diagnostic Trouble Codes (DTC).
  - 1 Follow all on-screen instructions until the application completes successfully.
  - 2 When all tasks are complete, go to the next Step.
- 6 Exit the current session.
  - 1 Select the **Session** tab.
  - 2 Select the **Close Session** option.
- 7 Disconnect the diagnostic tool and battery power supply from the vehicle.