

ATTENTION: This Technical Service Bulletin was issued by Gulf States Toyota, Inc.

For Toyota Dealers located in the Gulf States Toyota Region: Please refer to GST Dealer Daily to obtain instructions on how to order parts and submit a warranty claim (If applicable).

For Toyota Dealers *NOT* located in Texas, Oklahoma, Mississippi, Arkansas or Louisiana: For Repair Authorization, Parts Ordering, and Warranty Claims please contact GST Accessory Technical Support at 1-800-444-1074.

Thank you for your continued support.



GST-TSB-17-001

March 23, 2017

Service Category: Vehicle Interior

Section: Theft Deterrent /Keyless Entry

Market: USA

Alarm Triggering While Driving

Applicability

| YEAR(S) | MODEL(S) | INSTALLED ACCESSORY INFORMATION | | |
|-----------|----------|---------------------------------|--------------------|-----------------|
| | | DESCRIPTION | ACCESSORY LIO CODE | KIT PART NUMBER |
| 2013-2016 | RAV4 | Premium Security System | S6 | 00012-V1320-01 |
| 2017 | RAV4 | Premium Security System | S6 | 00012-V1620-01 |
| 2016-2017 | Corolla | Premium Security System | S6 | 00012-11620-01 |

Introduction

Some 2013-2017 RAV4 and 2016-2017 Corolla vehicles equipped with the GST Premium Security System accessory may exhibit improper function of the alarm, including a triggering of the alarm while driving, if the Power Outlet No.1 fuse is open. The following repair procedure will address this condition.

Parts Information

| Vehicle | Kit Part Number | Component Needed for Repair | Quantity Required per Vehicle |
|---------|-----------------|-----------------------------|-------------------------------|
| RAV 4 | 00012-01520-22 | 24-26 Gauge Black T-Tap | 1 |
| Corolla | 00012-01520-22 | 18-22 Gauge Red T- Tap | 1 |

| Vehicle | Part Number | Part Description | Quantity |
|-------------------|-------------|------------------|----------|
| RAV 4 and Corolla | 90982-09022 | 15A Mini-Fuse | 1 |

NOTE

NOT all items from the Kit will be needed for the repair.

Warranty Information

This repair is covered under the basic vehicle warranty. This warranty is in effect for **36 Months or 36,000 Miles**, whichever occurs first from the vehicle's In-service date.

| GST Installed Product | | | | |
|-----------------------|--------------------|----------------|----------------------|--|
| Model | RAV 4 2013-2016 | RAV 4 2017 | COROLLA 2016-2017 | DIO |
| Operation Code | B17021 | B17022 | B17023 | B17024 |
| OPF | 00012-V1320-01 | 00012-V1620-01 | 00012-11620-01 | 00012-V1320-01 00012-V1620-01 00012-11620-01 |
| Labor Time | 0.5 | 0.5 | 0.5 | 0.5 |

Repair Procedure

1. Disconnect Negative Battery Terminal.
2. Locate and inspect Power Outlet No.1 Fuse.

Is Power Outlet No.1 Fuse Open?

- **Yes** – Replace 15A fuse and proceed to Step 3
- **No** – This TSB does not apply

RAV4 Repair Procedure

3. Remove the fuse box opening cover by detaching the 8 clips illustrated in Fig.1

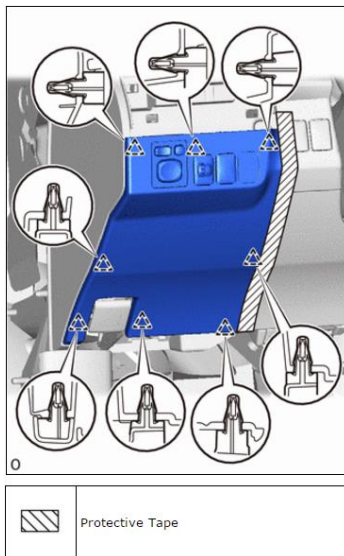

NOTE

Apply protective tape per Fig. 1 to avoid mutilation to vehicle.

Fig.1

RAV4 Repair Procedure (cont'd)

4. Locate the Instrument Panel J/B Assembly
 - a. Locate connector 3D

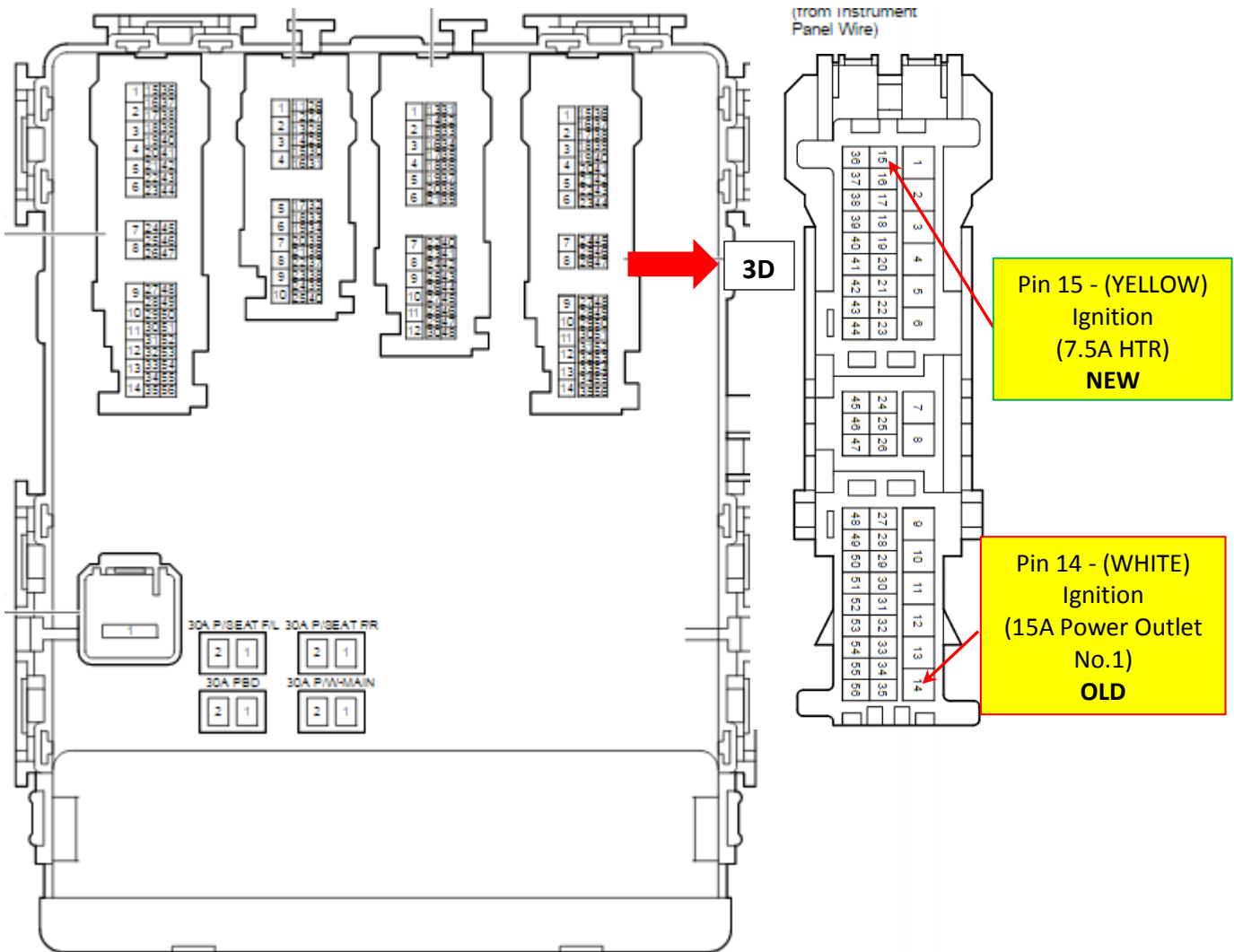

5. Disconnect the insulated female connector from the Red t-tap on PIN 14 Wire (White)
6. Reference Page 11 on **T-Tap Installation Guide**
7. Install Black T-Tap onto PIN 15 Wire (Yellow)
8. Re-connect insulated female connector onto installed Black T-Tap

NOTE

DO NOT REMOVE the RED T-TAP from PIN 14 Wire. It must remain on vehicle after repair is completed

GST-TSB-17-001

March 23, 2017

RAV4 Repair Procedure (cont'd)

9. Re-install the fuse box opening cover
10. Re-connect negative battery terminal and torque to **48 in./lbs**
11. Test Alarm System for proper function as listed on **Page 10**

Corolla Repair Procedure

16MY Corolla

3. Remove Fuse box opening cover

- Remove cover per Fig.1 and bolt per Fig.2

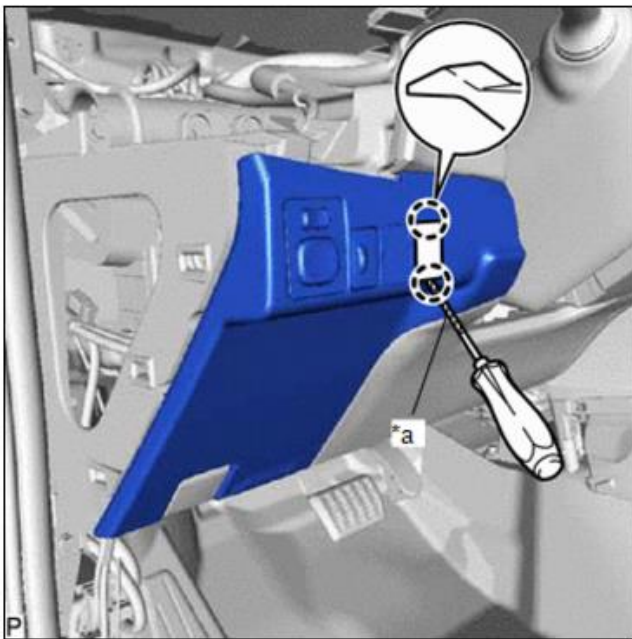

FIG.1

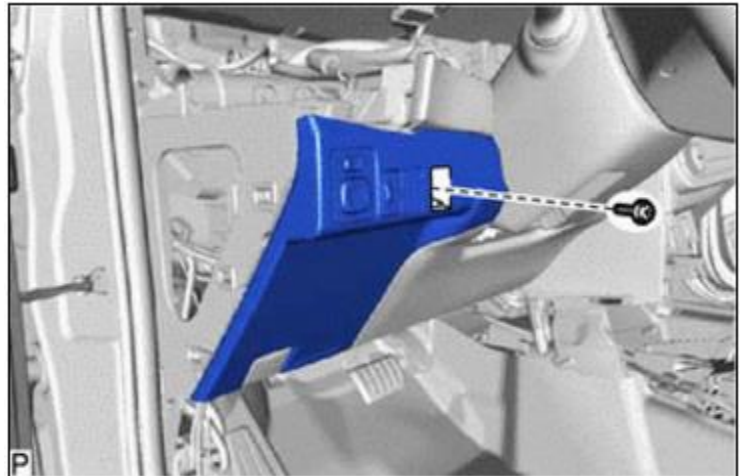

FIG. 2

Corolla Repair Procedure (cont'd)

17MY Corolla

3. Remove No.1 Meter Hood Cluster

- Apply protective tape to the area shown in **Fig. 3**
- Using molding remover, disengage the 3 clips and Remove the No.1 Meter Hood Cluster shown in **Fig. 4**

A. Disconnect the Front Door Opening Weatherstrip LH

B. Remove Instrument Side Panel LH shown in **Fig. 5**.

- Using molding remover, disengage the 6 clips in the direction indicated by the arrow

C. Remove No.1 Instrument Panel Register Assembly shown in **Fig. 6**.

- Disengage the 4 clips and Remove the No.1 Instrument Panel Register Assembly



Fig. 3

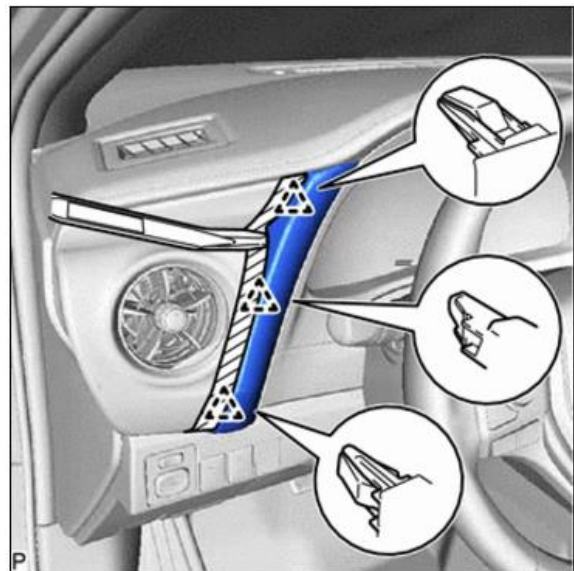

Fig. 4

Corolla Repair Procedure (cont'd)

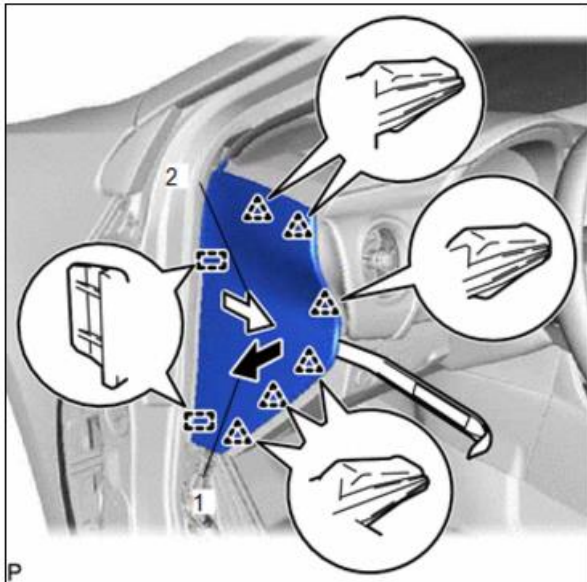

Fig. 5



Fig. 6

D. Remove Fuse box opening cover

- Remove cover per **Fig.7** and bolt per **Fig. 8**

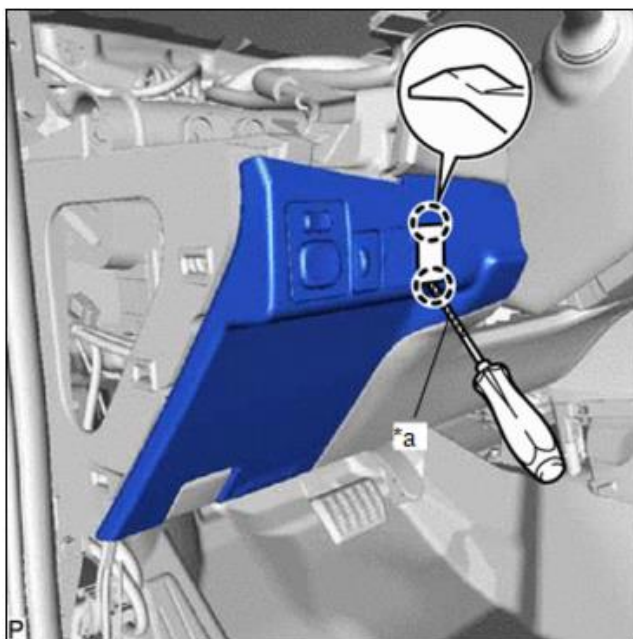

FIG. 7

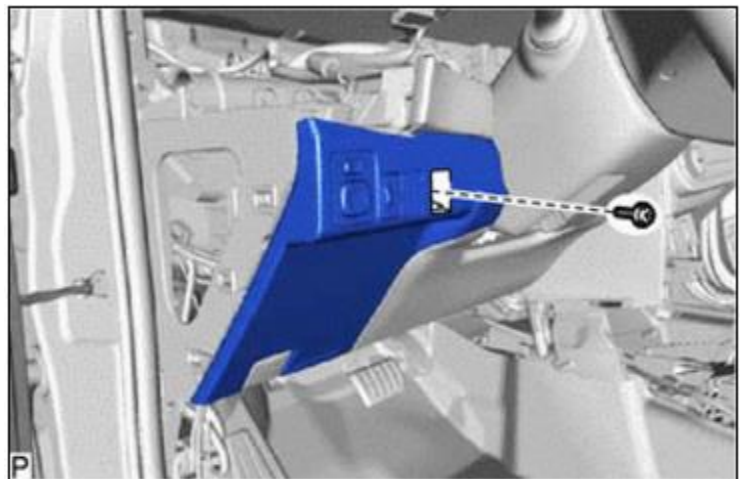

FIG. 8

GST-TSB-17-001

March 23, 2017

Corolla Repair Procedure (cont'd)

4. Locate the Instrument Panel J/B Assembly

a. Locate connectors 3C and 3D

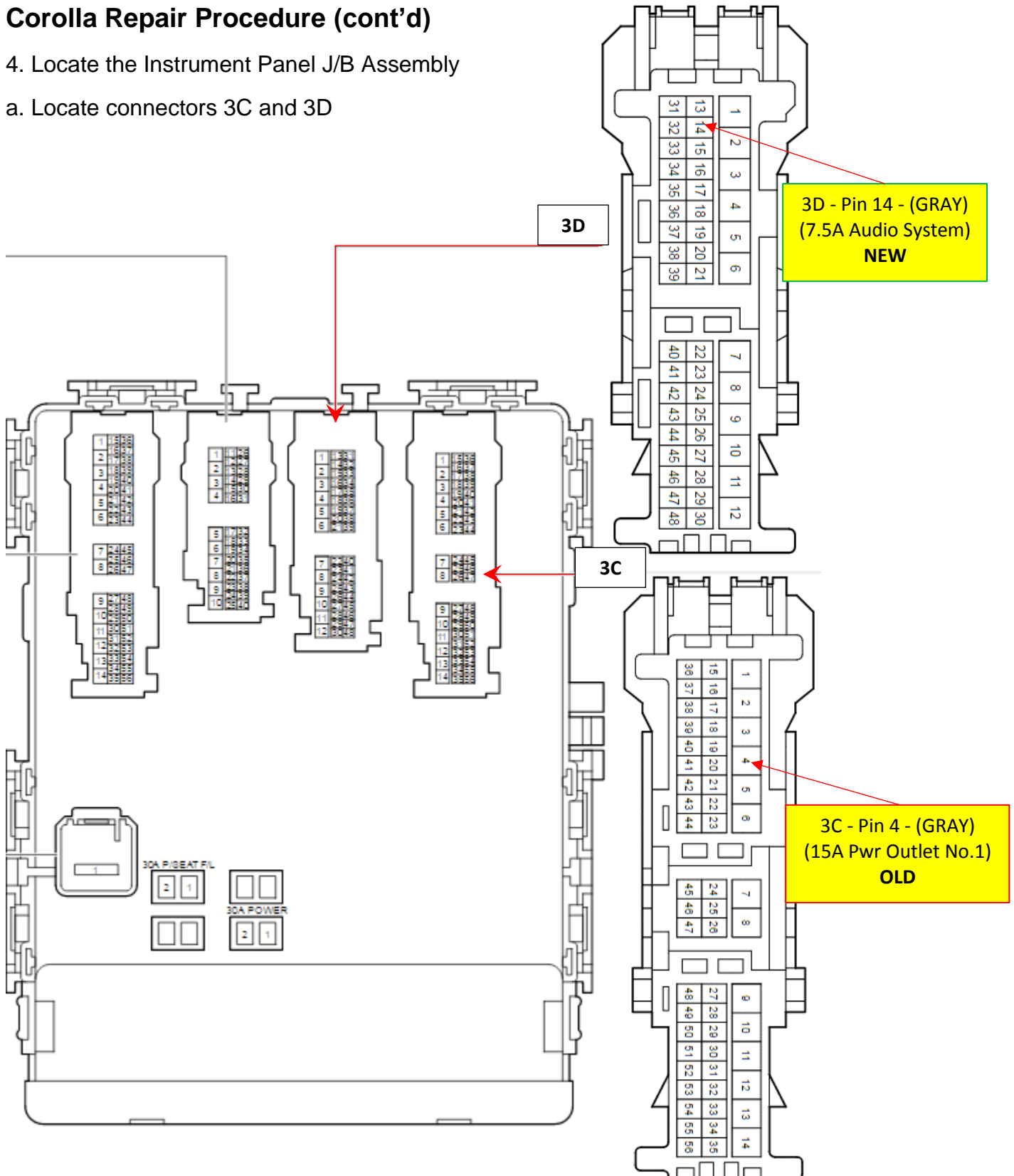



Corolla Repair Procedure (cont'd)

5. **16MY Corolla ONLY** - On Connector 3C – Is there a T-Tap present on PIN 4?
 - Yes – Proceed to Step 6
 - No – This TSB does not apply
6. On Connector 3C - Disconnect the insulated female connector from the Red t-tap on PIN 4 Wire (Gray)
7. Reference Page 11 on **T-Tap Installation Guide**
8. On Connector 3D - Install Red T-Tap onto PIN 14 Wire (Gray)
9. Re-connect insulated female connector onto installed Red T-Tap

NOTE

DO NOT REMOVE the RED T-TAP from PIN 4 Wire. It must remain on vehicle after repair is completed

10. Re-install the fuse box opening cover
11. Re-connect negative battery terminal and torque to 48 in./lbs.
12. Test Alarm System for proper function as listed on **Page 10**

TESTING ALARM SYSTEM:

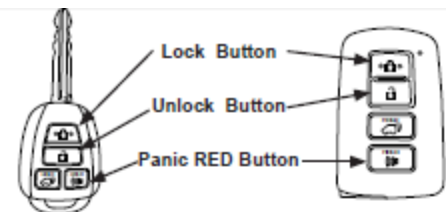

A. Test **BOTH** remote transmitters, one at a time. Press and release the "LOCK" button.

B. VALET CONTROL SWITCH:

1. Sit in the driver's seat, insert the ignition key and turn to the ON position.
2. Press the valet control switch and verify that the LED light responds. Light should go ON and OFF with actuation of the valet control switch.
3. With the LED indicator light ON, ignition OFF and key removed, the security system is in the valet mode and the alarm should not arm. Press the "LOCK" button, the lights will flash once, all doors will lock, headlights will come on for 20 seconds. Press the "UNLOCK" button, the lights will flash twice, driver's door only will unlock, headlights come on for 20 seconds.
4. Ignition key ON, LED light OFF, Ignition key OFF.

C. ARMING/DISARMING:

1. Put all vehicle windows down and close hood and all doors.
2. Press and release the "LOCK" transmitter button.
3. All doors should lock, lights flash once, horn chirps once, headlights come on for 20 seconds and the LED should flash slowly.
4. Press the "UNLOCK" button, the horn chirps (2) times, lights flash (2) times, headlights come on for 20 seconds, driver's door only unlocks.

D. SHOCK SENSOR:

1. Press the "LOCK" button to arm the system. With the open palm lightly slap the steering wheel. You should hear short chirps from the vehicle horn. This is a check of the shock sensor "WARN-AWAY" function. Allow a few seconds for the shock to settle, then conduct the same check at various points around the vehicle. Sensitivity can be adjusted at the shock sensor for best response, not to exceed Position 3.
2. Slap the steering wheel with slightly more force. The vehicle should go into full alarm. Press the "UNLOCK" button to disarm the system. Rearm the vehicle and conduct the same check at various points around the vehicle. Adjust sensitivity at the shock sensor for the best response.

E. IGNITION DISARM:

1. Sit in the driver's seat with all the doors closed. Press the "LOCK" button on the transmitter to arm the system. Insert the ignition key and turn to the start position. The alarm should disarm and the vehicle should start. If the alarm starts to sound, refer to OPTION PROGRAMMING on page 13.

F. DEFECTIVE OR LOST TRANSMITTER:

1. Press the "LOCK" button to arm the system. Reach in the driver's window to unlock and open the driver's door. The alarm will sound. Insert the key into the driver's door cylinder and turn to the unlock position. The alarm should deactivate.

G. REMOTE TRANSMITTER OPERATION:

1. Press the "LOCK" button, the system should arm and lock all doors.
2. Press the "UNLOCK" button, the system will also disarm and unlock the driver's door.
3. Press the "UNLOCK" button a second time and all doors should unlock.

H. INTRUSION TEST:

1. Rearm the security system by pressing the "LOCK" button. Open any protected door. The system should simultaneously sound the horn and flash the lights.
2. Disarm the security system by pressing the "UNLOCK" button. The system should sound (4) chirps of the horn, the lights should flash (4) times, indicating vehicle intrusion.
3. The LED should indicate the point of intrusion after disarming the system. Observe the LED for 1 or 3 flashes. Compare your observations to the following.
4. Repeat for each protected door.
5. Repeat this test for the trunk by pulling the remote trunk release lever on the driver's floor board.

- (1) Flash = Shock Sensor or Trunk
- (3) Flashes = Vehicle Doors

I. TEST DOOR LOCK SWITCH:

1. With drivers window open and alarm armed, press "UNLOCK" on the drivers door rocker switch and ensure alarm does not disarm.
2. With drivers window open and alarm disarmed, press "LOCK" on the drivers door rocker switch and ensure alarm does not arm.

SYSTEM AUTOMATICALLY CLEARS ALL STORED VIOLATIONS WHEN THE IGNITION SWITCH IS TURNED TO THE "ON" POSITION.

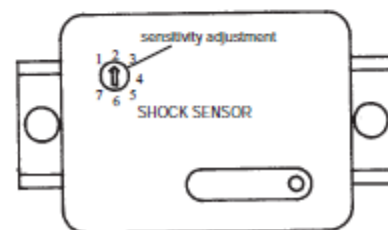

T-TAP Reference Information

STAGGER ALL T-TAPS WHEN MULTIPLE CONNECTIONS ARE ON A COMMON CONNECTOR

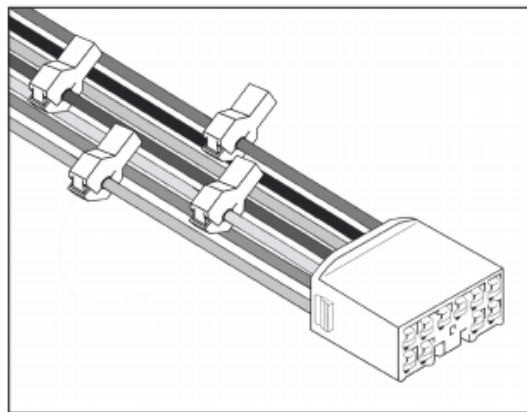

When applying multiple T-Taps to a common connector, the T-Taps must be staggered to avoid excessive stress/strain on the wires. T-Taps must also be applied at least 1 inch away from the connector housing.

T-TAP INSTALLATION

When installing T-Tap connectors, be sure the wire is located inside the wire channel of the T-Tap connector before closing the connector over the wire with pliers. When possible, install T-Taps at least 1" away from connector.

Step A



Step B

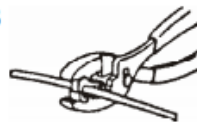

Step C

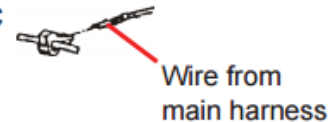

IMPORTANT! After installation, inspect and ensure that Keyless System Harnesses are clear of all HOT, SHARP or MOVING objects.

IMPORTANT! Care must be exercised when using the Black T-Taps. To avoid damage and broken wires, please note:

- **Ensure there is NO tension on the T-Tap connection when securing the harness. The wire should be slack.**
- **Excessive manipulation and/or stress on the wire connection could lead to wire breakage.**
- **Center the wire in the metal insert, NOT the plastic side of the T-Tap. Misalignment of the wire against the metal insert could lead to cutting the wire.**