



Emissions Recall

Code: 24CV

Subject	Inlet Air Box Housing Snow Flap Replacement & Oxygen Sensor Inspection/Replacement														
Release Date	August 11, 2017														
Important Repair Information!	<i>CAMPAIGN 24CV MUST BE COMPLETED BEFORE BEGINNING THE 23U3 CAMPAIGN!</i> <i>Over the next few weeks there will be updates made to ODIS and the campaign circular. Do not retain any hard copies of campaign circulars – only refer to the electronic copies posted to Elsa and ServiceNet.</i>														
Affected Vehicles	U.S.A. : 2009-2014 MY Volkswagen 2.0L TDI Engine Vehicles (Generation 1)														
	<table border="1"> <thead> <tr> <th>Country</th> <th>Model Year</th> <th>Vehicle Carline</th> </tr> </thead> <tbody> <tr> <td rowspan="5">USA</td> <td>2009-2014</td> <td>Jetta</td> </tr> <tr> <td>2009-2014</td> <td>Jetta SportWagen</td> </tr> <tr> <td>2012-2014</td> <td>Beetle</td> </tr> <tr> <td>2012-2014</td> <td>Beetle Convertible</td> </tr> <tr> <td>2010-2014</td> <td>Golf</td> </tr> </tbody> </table>	Country	Model Year	Vehicle Carline	USA	2009-2014	Jetta	2009-2014	Jetta SportWagen	2012-2014	Beetle	2012-2014	Beetle Convertible	2010-2014	Golf
Country	Model Year	Vehicle Carline													
USA	2009-2014	Jetta													
	2009-2014	Jetta SportWagen													
	2012-2014	Beetle													
	2012-2014	Beetle Convertible													
	2010-2014	Golf													
	<p>Check Campaigns/Actions screen in Elsa on the day of repair to verify that a VIN qualifies for repair under this action. Elsa is the <u>only</u> valid campaign inquiry & verification source.</p> <ul style="list-style-type: none"> ✓ Campaign status must show “open.” ✓ If Elsa shows other open action(s), inform your customer so that the work can also be completed at the same time the vehicle is in the workshop for this campaign. 														
Problem Description	<p>The snow flap in the inlet air box housing may remain partially to fully open. Should this occur, excess warm air could enter the air intake through the snow flap inlet.</p> <p>The oxygen sensor will be checked during this service and, if measured degradation tolerances are met, the sensor will be replaced.</p>														
Corrective Action	Install an improved inlet air box housing snow flap and, if measured degradation tolerances are met, replace the oxygen sensor.														
Parts Information	<p>3C0129594A (Snow Flap) - Parts will be allocated prior to owner notification. If allocated parts have been used and your dealership is at the weekly Upper Order Limit, please submit the backordered sales document number to upperorderlimits@vw.com to have additional parts released.</p> <p>G052172M2 (Special Anti-Friction Agent) – Each can of Special Anti-Friction Agent is intended to service 100 Snow Flap installations. If allocated parts have been used and your dealership is at the weekly Upper Order Limit, please submit the backordered sales document number to upperorderlimits@vw.com to have additional parts released.</p> <p>03L906262B (O2 Sensor) - Please contact the Parts Specialists via phone (800-767-6552, option#2), email (VWoAPartsSpecialists@vw.com) or chat with the VIN to order.</p>														
Code Visibility	<p>On or about August 11, 2017, affected vehicles will be listed on the Inventory Vehicle Open Campaign Action report under My Dealership Reports (found on www.vw.com & OMD Web). A list will not be posted for dealers who do not have any affected vehicles.</p> <p>On or about August 11, 2017, this campaign code will show open on affected vehicles in Elsa.</p> <p>On or about August 11, 2017, affected vehicles will be identified with this campaign code in the VIN Lookup tool at www.vw.com.</p>														

Owner Notification

Owner notification will take place in August 2017. An owner letter example is included in this bulletin for your reference.

Emissions Campaigns Requirements (CALIFORNIA ONLY)

The California Air Resources Board and the Department of Motor Vehicles (DMV) require emissions-related campaigns to be completed prior to vehicle registration renewal. When campaign work is done you must provide the owner with a signed "Vehicle Emission Recall – Proof of Correction" certificate (RC EMISCAVWAWU). Order certificates online via the Compliance Label Ordering portal at www.vwhub.com.

Additional Information

Please alert everyone in your dealership about this action, including Sales, Service, Parts and Accounting personnel. Contact Warranty if you have any questions.

Dealers must ensure that every affected inventory vehicle has this campaign completed before delivery to consumers.

Fill out and affix Campaign Completion Label (CAMP 010 000) after work is complete. *Labels can be ordered at no cost via the Compliance Label Ordering portal at www.vwhub.com.*

Claim Entry Instructions

After campaign has been completed, enter claim as soon as possible to help prevent work from being duplicated elsewhere. Attach the Elsa screen print showing action open on the day of repair to the repair order.

If customer refused campaign work:

- ✓ U.S. dealers: Submit request via WISE under the *Campaigns/Update/Recall Closure* option.

Service Number	24CV															
Damage Code	0099															
Parts Vendor Code	WVO															
Claim Type	Sold vehicle: 7 10 Unsold vehicle: 7 90															
Causal Indicator	Mark Snow Flap as causal part*															
Vehicle Wash/Loaner	Do not claim wash/loaner under this action															
Criteria I.D.	01															
	<p>Install new Snow Flap</p> <p>Labor operation: 2325 25 99 30 T.U.</p> <table border="1"><thead><tr><th>Quantity</th><th>Part Number</th><th>Description</th></tr></thead><tbody><tr><td>1.00</td><td>3C0129594A</td><td>Snow Flap*</td></tr><tr><td>0.01</td><td>G 052172M2</td><td>Special Anti-Friction Agent</td></tr></tbody></table> <p>-NOTE for 2009 Model Year Vehicles- It is NOT REQUIRED to replace the Heated O2 Sensor -G39- under this action, as the sensor will be replaced as part of the 23U3 Campaign.</p> <p>-AND if required- Check condition of Heated Oxygen Sensor (G39) Labor operation: 0150 00 00 up to 30 T.U. per GFF log.</p> <p>-AND IF NECESSARY per test results- Replace Heated Oxygen Sensor (G39) Labor operation: 2357 19 99 40 T.U.</p> <table border="1"><thead><tr><th>Quantity</th><th>Part number</th><th>Description</th></tr></thead><tbody><tr><td>1.00</td><td>03L906262B</td><td>Heated Oxygen Sensor (G39)</td></tr></tbody></table>	Quantity	Part Number	Description	1.00	3C0129594A	Snow Flap*	0.01	G 052172M2	Special Anti-Friction Agent	Quantity	Part number	Description	1.00	03L906262B	Heated Oxygen Sensor (G39)
Quantity	Part Number	Description														
1.00	3C0129594A	Snow Flap*														
0.01	G 052172M2	Special Anti-Friction Agent														
Quantity	Part number	Description														
1.00	03L906262B	Heated Oxygen Sensor (G39)														

Customer Letter Example

**Subject: Emissions Recall 24CV - Inlet Air Box Housing Snow Flap
2009-2014 MY Volkswagen 2.0L TDI Engine Vehicles (Generation 1)**

Dear Volkswagen Owner,

In cooperation with the United States Environmental Protection Agency and the California Air Resources Board, we are informing you of our decision to conduct an emissions recall on 2009-2014 MY Volkswagen 2.0L TDI engine vehicles (Generation I). Our records show that you are the owner of a vehicle affected by this action.

- What is the issue?** The snow flap in the inlet air box housing may remain partially to fully open. Should this occur, excess warm air could enter the air intake through the snow flap inlet.
- The oxygen sensor will be checked during this service and, if measured degradation tolerances are met, the sensor will be replaced.
- What will we do?** Your authorized Volkswagen dealer will install an improved inlet air box housing snow flap and, if measured degradation tolerances are met, replace the oxygen sensor. This work will take about an hour to complete and will be performed for you free of charge. Please keep in mind that your dealer may need additional time for the preparation of the repair, as well as to accommodate their daily workshop schedule.
- What should you do?** In order to limit any possible inconvenience, please contact your authorized Volkswagen dealer as soon as possible to schedule this service. For your convenience, you can also visit www.vw.com and click on the "Owners" link to locate a dealer near you and schedule this service online.
- Lease vehicles and address changes** If you are the lessor and registered owner of the vehicle identified in this action, please forward this letter immediately via first-class mail to the lessee within ten (10) days of receipt. If you have changed your address or sold the vehicle, please fill out the enclosed prepaid Owner Reply card and mail it to us so we can update our records.
- Important information for California Vehicle Owners – California Regulations** California regulations require that this campaign be completed prior to the time you renew your vehicle registration. Therefore, **please make sure that this campaign is completed prior to the renewal of your vehicle registration**, and that you furnish proof of completion to the Department of Motor Vehicles (DMV) in the form of a copy of the dealer's repair order, including a signed "Proof of Correction" certificate. You obtain this from your dealer after the campaign has been completed. Please retain the signed "Proof of Correction Certificate" with your vehicle records. **DO NOT MAIL THIS FORM** to the DMV, unless requested.
- Can we assist you further?** If your authorized Volkswagen dealer fails or is unable to complete this work free of charge within a reasonable time, or if you should have any questions about this communication, please reach out to us using your preferred method of communication at www.vw.com/contact or by calling 1 800-893-5298. Our phone team is available Monday through Friday from 8AM to 10PM EST and Saturday from 9AM to 5PM EST.
- Checking your vehicle for open Recalls and Service Campaigns** To check your vehicle's eligibility for repair under this or any other recall/service campaign, please click on the **Look Up Recalls** link at www.vw.com and enter your Vehicle Identification Number (VIN) into the **Recall/Service Campaign Lookup** tool.

We apologize for any inconvenience this matter may cause; however we are taking this action to help ensure your vehicle continues to meet and exceed your expectations.

Sincerely,

Volkswagen Customer Protection

ATTENTION!
 Damages resulting from improper repair or failure to follow these work instructions are the dealer's responsibility and are not eligible for reimbursement under this action.

Required Parts

Quantity	Part Number	Part Description
1	3C0 129 594 A	Snow Flap
0.01	G 052 172 M2	Special Anti-Friction Agent
1 (if necessary)	03L 906 262 B	Heated Oxygen Sensor (G39)

Required Tools



- VAS6150X – Diagnostic Tester (or equivalent)
- VAS5054X – Remote Diagnosis Head (or equivalent)



- 3337 – Ring Wrench 7-piece set (or equivalent)

The repair information in this document is intended for use only by skilled technicians who have the proper tools, equipment and training to correctly and safely maintain your vehicle. These procedures are not intended to be attempted by "do-it-yourselfers," and you should not assume this document applies to your vehicle, or that your vehicle has the condition described. To determine whether this information applies, contact an authorized Volkswagen dealer. ©2017 Volkswagen Group of America, Inc. All Rights Reserved.

Applicable criteria ID(s)	Campaign/Action Status
01 ← 2	Open ← 1

EXAMPLE

TIP

If Campaign Completion label is present, no further work is required.

- Enter the VIN in Elsa and proceed to the “Campaign/Action” screen.

TIP

On the date of repair, print this screen and keep a copy with the repair order.

- Confirm the Campaign/Action is open <arrow 1>. If the status is closed, no further work is required.
- Note the Applicable Criteria ID <arrow 2> for use in determining the correct work to be done and corresponding parts associated.

Proceed to Section B

Section B – Check, and if necessary, Replace Heated Oxygen Sensor (G39)

NOTE

-2009 Model Year Vehicles ONLY-

It is **NOT** required to replace the Heated O2 Sensor -G39- for 2009 Model Year vehicles because a new Heated Oxygen Sensor -G39- is included in the Base Kit II for the 23U3 campaign. Although it is not necessary to replace the sensor under this action, it **IS REQUIRED** to reset the Heated Oxygen Sensor -G39- adaptation values if the sensor check shows the sensor is out of range. For 2009 Model Year vehicles, check the “Filtered oxygen value” in the following steps, and if determined to be out of range, follow the instructions to reset the adaptation values.

NOTE

At this time it is required to complete this action prior to beginning **Campaign 23U3**. Campaign 23U3 requires the condition of the Heated O2 Sensor -G39- to be verified before beginning the flash operations contained in that action.

THIS CAMPAIGN MUST BE COMPLETED PRIOR TO STARTING THE 23U3 CAMPAIGN!

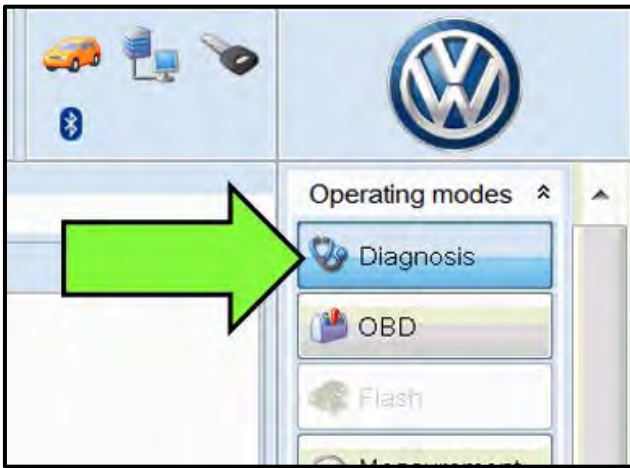

Check condition of Heated Oxygen (O2) Sensor -G39-

- Switch the ignition on.
- Connect the VAS6150X Diagnostic Tester (or equivalent) to the vehicle.
- Start the ODIS program.
- Upon ODIS startup, verify the "Diagnosis" operating mode is selected <arrow>.

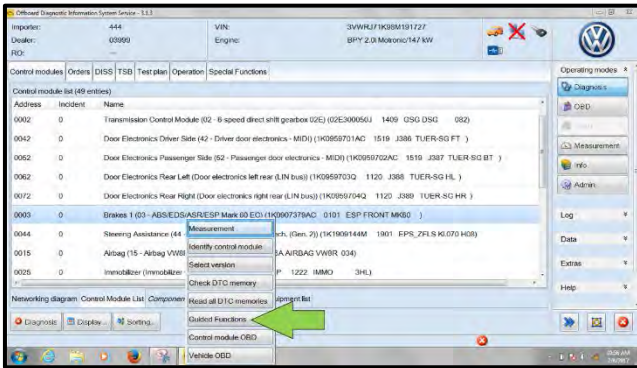

- Select the "Control Module" tab.
- Scroll down and right click on Address Word 0001/ Engine Control Module.
- Select "Guided Functions" <arrow>.

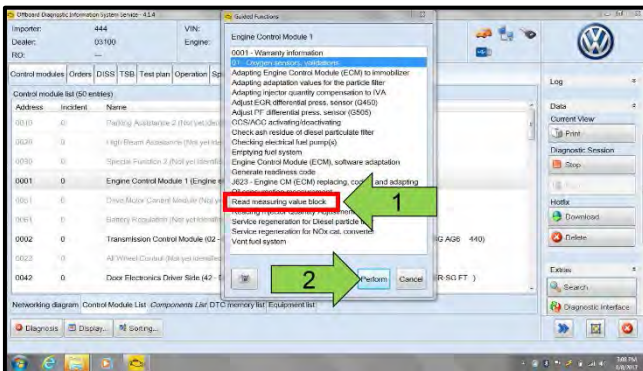

- Select "Read measuring value block" <arrow 1>.
- Select "Perform" <arrow 2>.

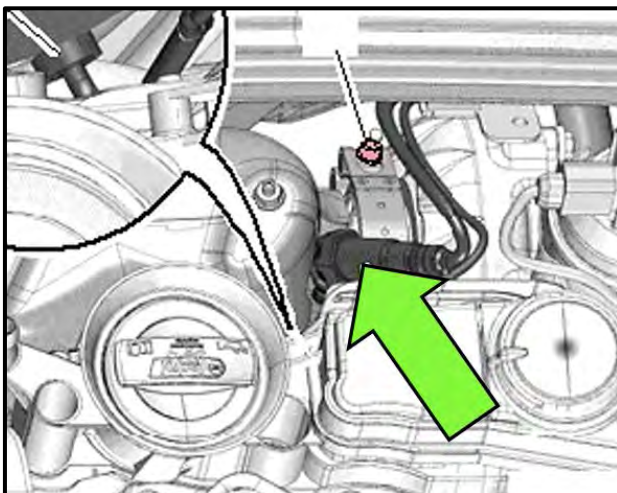
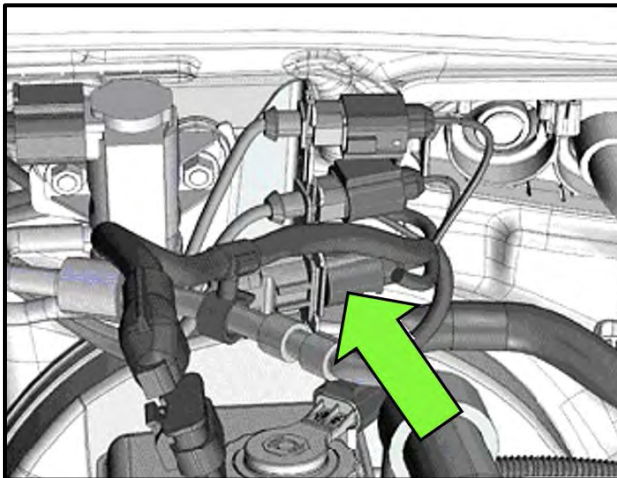
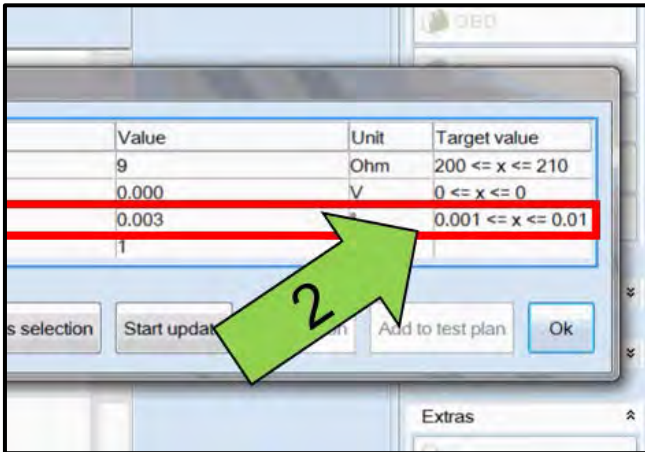
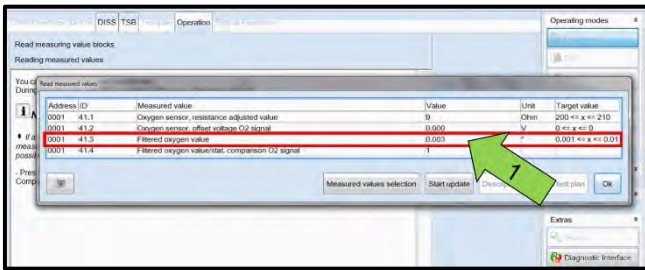

- Using the search function, locate measuring value block **41.3** for “Filtered oxygen value” <arrow 1>.
- Read measuring value block **41.3** for “Filtered oxygen value” <arrow 1>. The measured value for a **GOOD** Heated Oxygen Sensor -G39- will read within the following range:
 - **Greater than: 0.0019**
 - **Less than: 0.0100**
- If the Filtered oxygen value <arrow 2> listed is **WITHIN** this range, the sensor is **OK** and does not require replacement.
 - **Proceed to Section C** and replace the Snow Flap.
- If the Filtered oxygen value listed is **ABOVE**, or **BELOW** this range, the sensor is **BAD** and requires replacement.
 - Proceed to the next step.

- Switch ignition off.
- Remove the engine cover.
- Disconnect the Heated Oxygen Sensor -G39- electrical connector <arrow>.
- Free up the wiring harness.

- Loosen and remove the original heated O2 sensor -G39- <arrow> from diesel particulate filter using the ring wrench 7-piece set -3337-.
- Install new heated O2 sensor -G39- <arrow> (part number **03L 906 262 B**) into diesel particulate filter using the ring wrench 7-piece set -3337- and torque to 50 Nm.
- Reconnect electrical connector and reinstall engine cover.

NOTE

Risk of Damaging O2 Sensor
 Grease only the threads with Hot Bolt Paste (G 052112A3). The Hot Bolt Paste must not get into the slots on the sensor body.



- After replacing the Heated Oxygen Sensor -G39-, the oxygen sensor adaptation values must be reset.
- **STOP**, create a VTA ticket and contact the Volkswagen Technicians Helpline.
 - The Volkswagen Technicians Helpline will assist you with installing a HotFix into the ODIS Software that activates a test plan for resetting the O2 Sensor adaptation values, and other associated learned value blocks.
 - Follow the direction of the Volkswagen Technicians Helpline consultant to complete the resetting the O2 Sensor adaptation values, and other associated learned value blocks AFTER the sensor has been replaced.



NOTE

-When performing Campaign 23U3-

If the Heated Oxygen Sensor -G39- was checked, found bad, and replaced under this action, you **MAY** still receive the following message **“Replace the heated oxygen sensor -G39- (before catalytic converter), Refer to the Repair Manual, Repair Group 23”** <arrow 1> when performing the flash procedure during Campaign 23U3. It does not indicate a failed sensor, or improperly reset adaptation values.

It is normal to receive this message while performing the flash operation during Campaign 23U3 if the Heated Oxygen Sensor -G39- was found to be bad, and replaced. Appearance of this message does not indicate a new, failed sensor.

The new sensor requires adaptation to the new ECM software in order for the 23U3 flash self-check routine to “pass” the new sensor.

Disregard this message if it is received after sensor replacement. Select “Complete/continue” <arrow 2> to bypass.

- End the GFF session and send the GFF Log online.

Proceed to Section C

Section C – Replace Snow Flap



- Remove low pressure hose <1> from air filter housing.



- Disconnect mass air flow (MAF) connector <1> -G70-.

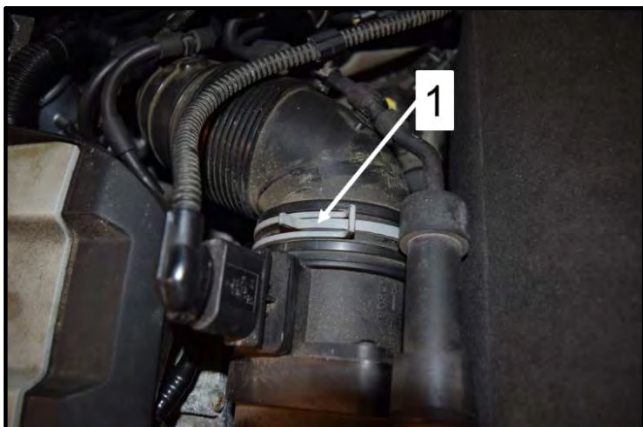

- Loosen clamp <1> to remove air duct hose.

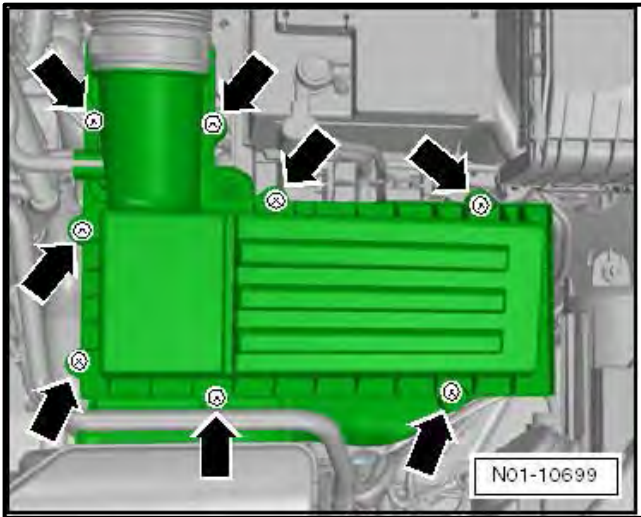

- Loosen the eight airbox cover screws <arrows> and remove the airbox cover.

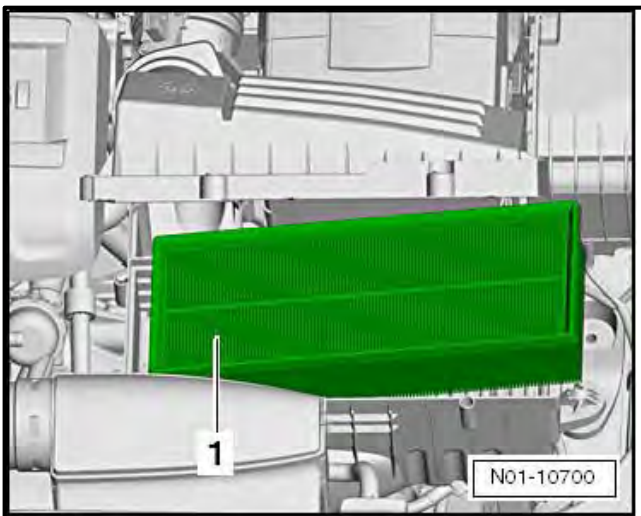

- Remove the air filter <1> from the lower airbox.

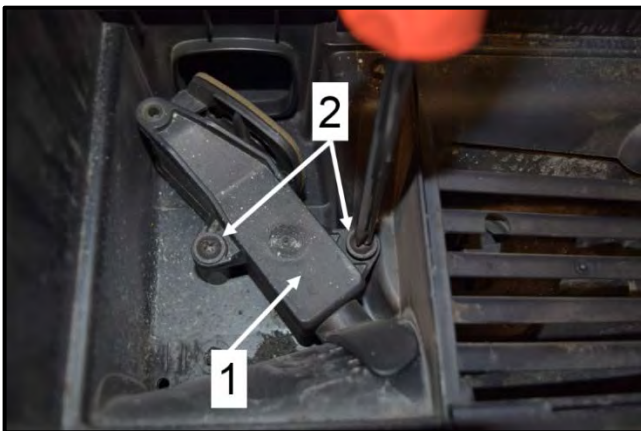

- Loosen the two screws <2> on the snow flap and remove them.
- Lift the snow flap <1> out of the airbox base and remove it.



TIP

The new snow flap when at rest and at normal room temperature (70 F or 21 C) may appear to be extended in the closed position further than the old flap. This condition is normal.



- Before installing the new Snow Flap, apply a small amount (approx. 1 ml) of Special Anti-Friction Agent to the Snow Flap operating piston <arrow A>.
- Remove any excess or oversprayed Special Anti-Friction Agent using a cloth or rag before installing the new Snow Flap into the airbox.

Part Number	Part Description
3C0 129 594 A	Snow Flap
G 052 172 M2	Special Anti-Friction Agent

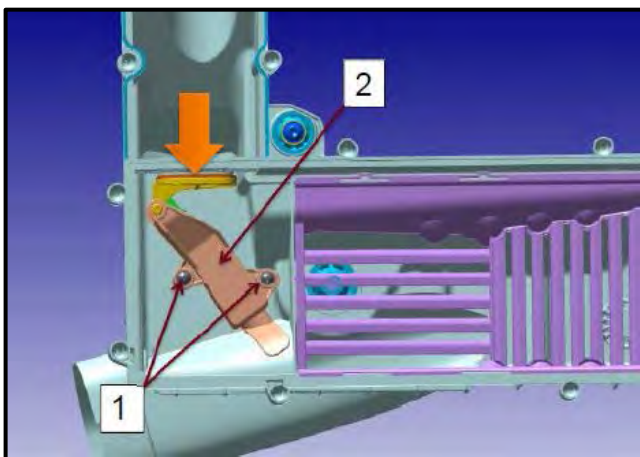

- Install the new snow flap by pushing the flap in the direction of the arrow towards the closed position for easier installation.
- Install and tighten the two screws <1> to 1.6 Nm.



NOTE

IN-FORM Tool REQUIREMENT

The TDI IN-FORM Tool **REQUIRES** a photograph of the new Snow Flap to be uploaded in order to fulfil the requirements of Campaign 23U3.

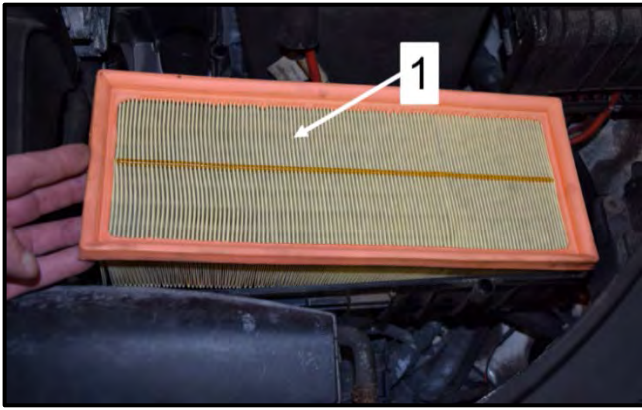

- Reinstall the air filter <1> into the lower airbox.



- Reinstall air duct hose in the direction of the <arrow> and reinstall the clamp.

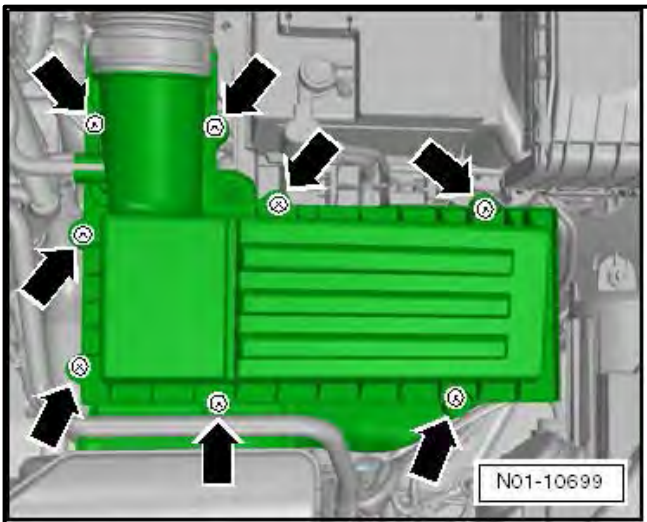

- Reinstall the air filter cover and tighten the bolts <arrows> to 2 Nm.



- Reconnect mass air flow (MAF) connector <2> -G70-.



- Reinstall low pressure hose <1> onto air filter housing.

ALL WORK COMPLETE

Proceed to Section D

Section D – Campaign Completion Label

Install Campaign Completion Label

- Fill out and affix Campaign Completion Label, part number CAMP 010 000, next to the vehicle emission control information label.

***i* TIP**

Ensure Campaign Completion Label does not cover any existing label(s).

ALL WORK COMPLETE

Proceed to Section E

Section E - Parts Return/Disposal

Properly store (retain), destroy or dispose of removed parts in accordance with all state/province and local requirements, unless otherwise indicated and/or requested through the Warranty Parts Portal (WPP).

Proceed to Section F (California only).

Section F – California Only Requirements

CALIFORNIA ONLY Requirements for Emissions Campaigns Having Customer Notification

The California Air Resources Board and the Department of Motor Vehicles (DMV) require emissions-related campaigns to be completed prior to vehicle registration renewal. **When campaign work is done you must provide the owner with a signed “Vehicle Emission Recall – Proof of Correction” certificate (RC EMIS_CAL VW).** Certificates can be ordered at no cost online via the Compliance Label Ordering portal at www.vwhub.com.

TIP

Ensure owners are aware of the importance of retaining the completed certificate for their records. It should be mailed to the California DMV only upon request.