

# ***SERVICE PROCEDURE***

17510  
November, 2017

**SUBJECT:** SAFETY RECALL

**Air Brake Hose Routing on certain RE school bus models built 04 November 2014 thru 27 March 2017**

## **DEFECT DESCRIPTION**

The air brake drop hose on the steer axle may contact the tire when wheels are turned to their fullest travel. Drop hose contact with the tire may cause an air leak at the hose resulting in a pull condition during brake application or an unexpected increase in stopping distance. This could cause a vehicle crash which may result in property damage or personal injury.

## **MODELS INVOLVED**

Certain RE school bus models built 04 November 2014 thru 27 March 2017.

## **ELIGIBILITY**

This procedure applies ONLY to vehicles marked in the International® Service Portal<sup>SM</sup> with Safety Recall 17510. Also complete any other open campaigns listed on the Service Portal at this time.

## **SPECIAL TOOLS**

Print the templates at the end of this letter to create an Installation Gauge to measure 45-degree orientation of the 90-degree fitting inwards and the 45-degree fitting is facing down.

## PARTS INFORMATION

Part Number	Part Description	Quantity
3576380C1	Hose, Flexible Air	As Needed
BX801552	Transmitter-Speed Sensor WS-24	As Needed
Source Locally	Cable Tie Strap	As Needed

## SERVICE PROCEDURE

**GOVERNMENT REGULATION:** Engine fluid (oil, fuel, and coolant) may be a hazard to human health and the environment. Handle all fluid and other contaminated materials (such as filters and rags) in accordance with applicable regulations. Recycle or dispose of engine fluids, filters, and other contaminated materials according to applicable regulations.

**WARNING!** To prevent property damage, personal injury, and / or death, park vehicle on hard flat surface, turn the engine off, set the parking brake and install wheel chocks to prevent the vehicle from moving in either direction.

**WARNING!** To prevent property damage, personal injury, and / or death, if the vehicle must be raised, do not work under the vehicle supported only by jacks. Jacks can slip or fall over.

**WARNING!** To prevent personal injury and / or death, always wear safe eye protection when performing vehicle maintenance.

**WARNING!** To prevent property damage, personal injury, and /or death, allow engine / vehicle components to cool before servicing.

**WARNING!** To prevent property damage, personal injury, and / or death, keep flames or sparks away from vehicle and do not smoke while servicing the vehicle's batteries. Batteries expel explosive gases.

**WARNING!** To prevent property damage, personal injury, and / or death, remove the ground cable from the negative terminal of the battery box before disconnecting any electrical components. Always connect the ground cable last.

1. Park vehicle on flat surface.
2. Shift transmission to Park or Neutral and set parking brake.
3. Install wheel chocks.

**NOTE: Guideline for replacing the flexible air hose or speed sensor transmitter: if the flexible air hose shows signs of the cords in the hose or the outside of the harness is worn through they should be replaced.**

4. Inspect ABS harness and drop hose on right-side and left-side steer axle chambers for contact damage that would affect hose life.
5. If damage is found replace ABS harness or hose.
6. Use tie wraps to secure harness on top of hose.

**NOTE: Do not print with custom scale, fit to page, or shrink options.**

7. Create alignment template, see attached document.
  - Print attached Fitting Orientation Template.
  - Cut out border of individual templates.
  - Adhere one template to a piece of cardboard.
  - Trim cardboard accordingly to edge of template border.
  - Adhere remaining template to opposite side of cardboard.

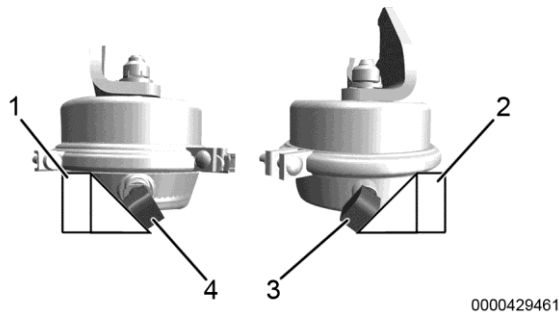

**Figure 1. Brake Chamber Fitting Orientation.**

1. Template left-side
2. Template right-side
3. Drop hose fitting orientation – right-side
4. Drop hose fitting orientation – left-side

**NOTE: Incorrectly installed fittings must be reoriented to the correct position, in the tightening direction only. If the fitting must reorient in the loosening direction, it must be completely removed and reinstalled.**

**NOTE: If a fitting combination must be removed, the 45-degree fitting must first be disassembled from the 90-degree fitting, then remove the 90-degree fitting from the brake chamber. Reverse this process to reinstall.**

8. On both front brake chambers, using Fitting Orientation Templates (Figure 1, Items 1 and 2), Turn 90-degree fitting (Figure 1, items 3 and 4) inward 45-degree and turn 45-degree fitting facing down.
9. Once fittings are correctly oriented, turn the steer wheels to their fullest position in both directions and verify there is no drop hose or speed sensor harness contact with the steer tires.
10. Remove wheel chocks.

## **END OF SERVICE PROCEDURE**

### **LABOR INFORMATION**

<b>Operation Number</b>	<b>Description</b>	<b>Time</b>
A40-17510-1	Re-orientation Both Sides	0.7 hrs
A40-17510-2	Replacing Each ABS Harness	0.1 hrs
A40-17510-3	Replacing Each Hose	0.1 hrs

---

#### **VEHICLE RECALL 17510**

## CAMPAIGN IDENTIFICATION LABEL

Each vehicle corrected in accordance with this campaign must be marked with a CTS-1075 Campaign Identification Label.

Complete the label and attach on a clean surface next to the vehicle identification number (VIN) plate.



## ADMINISTRATIVE / DEALER RESPONSIBILITIES

### WARRANTY CLAIMS

Warranty claim expense is to be charged to Warranty. Claims are to be submitted in the normal manner, making reference to Safety Recall 17510.

Section 7 of the Warranty Policy and Procedures Manual contains further information related to the submission and processing of AFC / Recall claims.

As with all claim submissions, items acquired locally must be submitted in the "Other Charges" tab. The cost of any bulk items (such as a bag of cable tie straps, roll of wire, barrel of oil, or tube of silicone) should be prorated for the cost of the individual pieces / amount used during each repair.

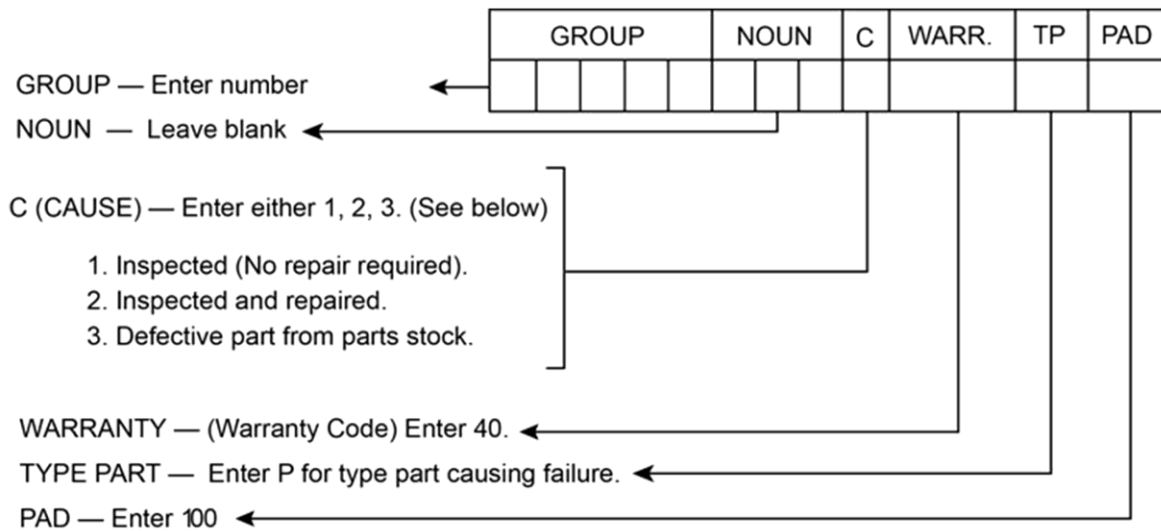

0000047910

## **VEHICLE RECALL 17510**

## **UNITED STATES AND POSSESSIONS**

The National Traffic and Motor Vehicle Safety Act, as amended, provides that each vehicle that is subject to a vehicle recall campaign must be adequately repaired within a reasonable time after the owner has tendered it for repair. A failure to adequately repair within 60 days after a tender of a vehicle is prima facie evidence of failure to repair within a reasonable time. If the condition is not adequately repaired within 60 days, the owner may be entitled to replacement with an identical or reasonable equivalent vehicle at no charge, or to a refund of the purchase price less a reasonable allowance for depreciation.

Dealers must correct all vehicles subject to this campaign at no charge to the owner, regardless of mileage, age of vehicle, or ownership, from this time forward.

Dealers should proceed immediately to make necessary correction to units in inventory. All inventory vehicles subject to this recall campaign must be corrected prior to sale, transfer or delivery. If vehicles have been sold or transferred and you are in receipt of Customer Notification Letters and Authorization for Recall Service cards for those vehicles, the transfer location or customer must be notified immediately from your dealer location.

Dealers must make every effort to promptly schedule an appointment with each owner to repair his or her vehicle as soon as possible. However, consistent with the customer notification, dealers are expected to complete the repairs on the mutually agreed upon service date.

Dealers involved in the recall process will be furnished a listing of owner names and addresses to enable them to follow up with owners and have the vehicles corrected. Use of this listing must be limited to this campaign because the list may contain information obtained from state motor vehicle registration records, and the use of such motor vehicle registration data for purposes other than this campaign is a violation of law in several states.

## **CANADA**

Dealers must correct all vehicles subject to this campaign at no charge to the owner, regardless of mileage, age of vehicle, or ownership, from this time forward.

Dealers should proceed immediately to make necessary correction to units in inventory. All inventory vehicles subject to this recall campaign must be corrected prior to sale, transfer or delivery. If vehicles have been sold or transferred and you are in receipt of Customer Notification Letters and Authorization for Recall Service cards for those vehicles, the transfer location or customer must be notified immediately from your dealer location.

Dealers must make every effort to promptly schedule an appointment with each owner to repair his or her vehicle as soon as possible. However, consistent with the customer notification, dealers are expected to complete the repairs on the mutually agreed upon service date.

Dealers involved in the recall process will be furnished a listing of owner names and addresses to enable them to follow up with owners and have the vehicles corrected. Use of this listing must be limited to this campaign because the list may contain information obtained from state motor vehicle registration records, and the use of such motor vehicle registration data for purposes other than this campaign is a violation of law in several states.

### **EXPORT**

Export Distributors should proceed immediately to make necessary correction to units in inventory. All inventory vehicles subject to this recall campaign must be corrected prior to sale, transfer or delivery. If vehicles have been sold or transferred and you are in receipt of Customer Notification Letters and Authorization for Recall Service cards for those vehicles, the transfer location or customer must be notified immediately from your distributor location.

Export Distributors are to submit warranty claims in the usual manner making reference to this recall number.

Export Distributors are expected to provide full cooperation and follow-up with respect to this important subject matter. If you have any questions or need further assistance, please contact the Regional Service Manager at your regional office.

## **NAVISTAR, INC.**

# Fitting Orientation Template

Front of Vehicle

Left Brake Chamber Band Clamp

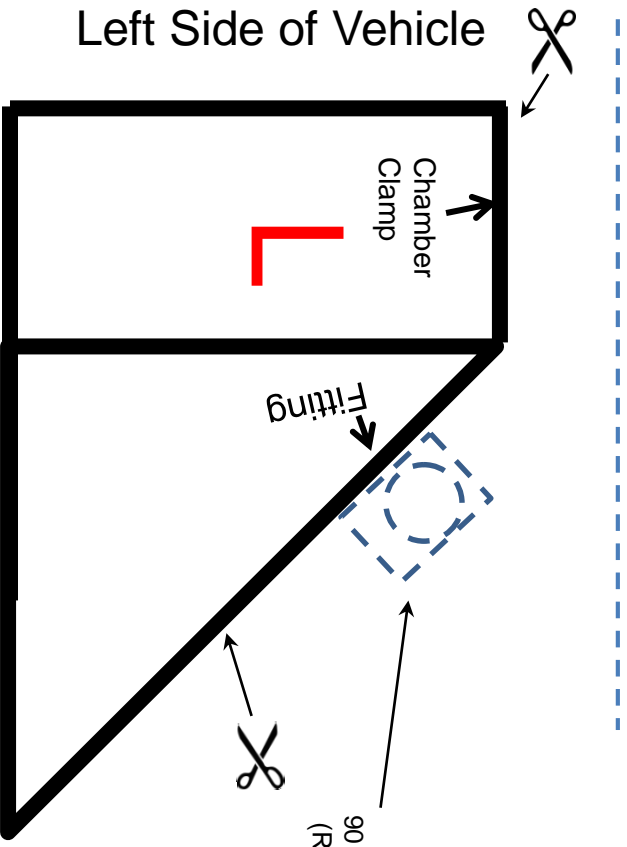

Right Brake Chamber Band Clamp

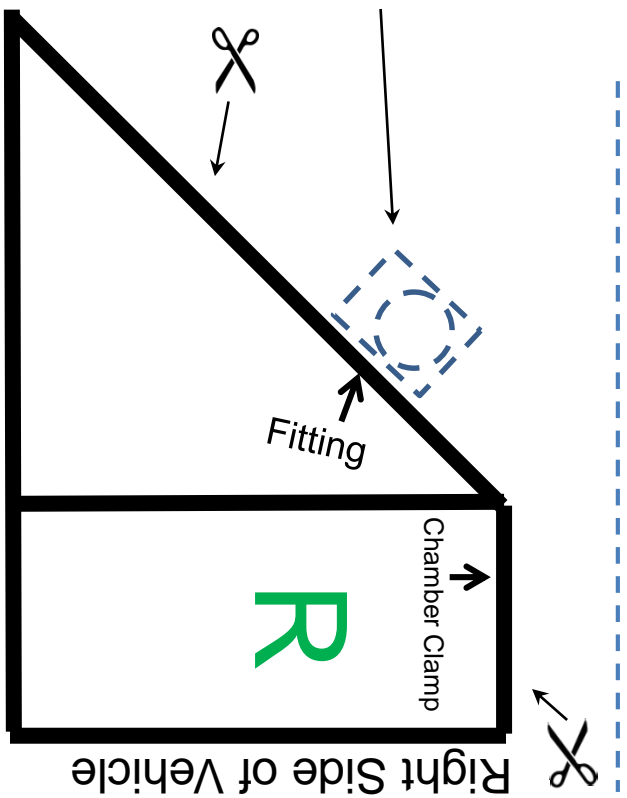

Cut along entire outer border of each individual template.

**NOTE:** Template must be printed with Actual Size option selected.

**DO NOT** print template with Shrink to Fit, Fit to Page, or Custom Scale options.