



**Countries:** CANADA, UNITED STATES, MEXICO  
**Availability:** ISIS, IsSIR  
**Major System:** COOLING  
**Current Language:** English  
**Other Languages:** NONE  
**Viewed:** 209

**Document ID:** IK0900122  
**Revision:** 2  
**Created:** 8/3/2017  
**Last Modified:** 11/27/2017  
**Author:** Greg Scheff

[Less Info](#)

Hide Details

Coding Information

<b>Copy Link</b> 	<b>Copy Relative Link</b> 	<b>Bookmark</b>  <a href="#">View My Bookmarks</a>	<b>Add to Favorites</b> 	<b>Print</b> 	<b>Provide Feedback</b> 	<b>Helpful</b>  7	<b>Not Helpful</b>  1
----------------------	-------------------------------	--	-----------------------------	------------------	-----------------------------	-------------------------	-----------------------------

**Title:** Loose or Missing Charge Air Cooler Clamps and Possible DPF Plugging

**Applies To:** Chassis Equipped with Cummins B6.7

## CHANGE LOG

Please refer to the change log text box below for recent changes to this article:

08/03/2017 - Initial Article Release  
 11/27/2017 - Added photo of clamp placement

## DESCRIPTION

This document will guide the user through repairing units with loose or missing CAC clamps, and correcting any contingent damage.

## SYMPTOM(s)

Sudden loss of power, loud pop heard under the hood, and possible exhaust plugging.

### **Customer Observations or Concerns:**

The customer will likely hear a loud pop under the hood, followed by a sudden loss of engine horsepower. Continued operation afterwards, will result in rapid plugging of the DPF. The check engine light will likely come on afterwards due to high soot loading and low boost pressure.

## SPECIAL TOOL(s) / SOFTWARE

Not Applicable

## SERVICE PARTS INFORMATION

Description	Part Number	Quantity Required	Notes
Clamp, Rad Outlet Pipe	1622369C1	As Needed	Turbo Outlet Pipe to CAC
Clamp, Air Cleaner Tube or Pipe	2026730C1	As Needed	CAC Outlet
Clamp, Air Duct Hose	2006496C1	As Needed	CAC Pipe at Engine Intake Elbow

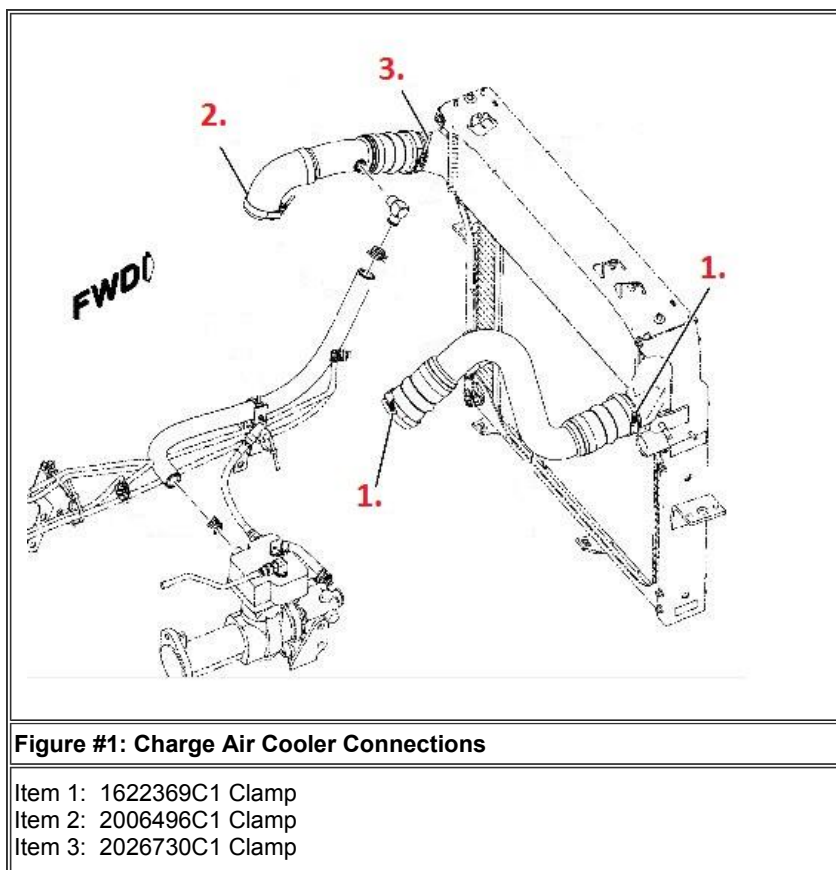

## REPAIR STEP(s)

**WARNING!** To prevent property damage, personal injury, and / or death, park vehicle on a hard, flat surface, turn the engine off, set the parking brake, and install wheel chocks to prevent the vehicle from moving in either direction.

**WARNING!** To prevent property damage, personal injury, and / or death, if the vehicle must be raised, do not work under the vehicle supported only by jacks. Jacks can slip or fall over.

**WARNING!** To prevent personal injury and / or death, always wear safe eye protection when performing vehicle maintenance.

**WARNING!** To prevent property damage, personal injury, and / or death, keep flames or sparks away from vehicle and do not smoke while servicing the vehicle's batteries. Batteries expel explosive gases.

**WARNING!** To prevent property damage, personal injury, and / or death, remove the ground cable from the negative terminal of the battery box before disconnecting any electrical components. Always connect the ground cable last.

If after inspection any of the CAC clamps are found to be loose or missing, perform the following steps.

1. Inspect the CAC boots, and piping for any damage. Replace boots as needed if any damage is found.
2. Install and torque all missing or loose CAC clamps (Figure #1), and torque to 11 Nm (8 ft. lbs.). Ensure clamp is positioned correctly while torquing. See image below:

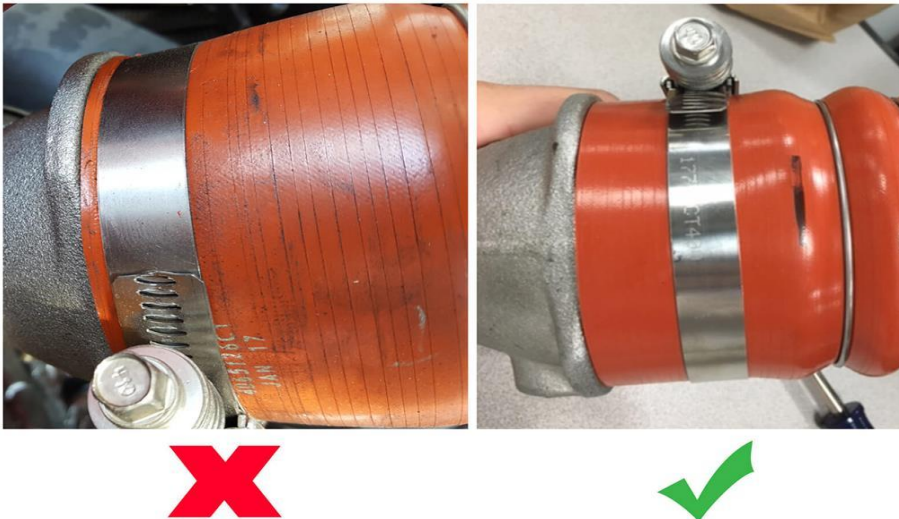

3. Inspect air compressor inlet hose (if equipped) for any damage or loose clamps.
4. Hook up the service tool, run the engine and inspect for any high soot loading fault codes.
5. If any high soot load codes are present, attempt to perform a manual stationary regen using the service tool.
6. If the regen is successful and no other issues are present, return the unit to service.
7. If the regen is NOT successful and the DPF is completely plugged, replace the DPF and retest for any further issues.

## **WARRANTY INFORMATION**

### **Warranty Claim Coding:**

<b>Group:</b>	09046 - Charge Air Cooler
<b>Noun:</b>	853 - Clamp, Charge Air Cooler

Refer to the [Warranty Coding Manual](#) for Group and Noun Codes.

## **OTHER RESOURCES**

[Master Service Information Site](#)

Hide Details		Feedback Information	
		Viewed:	208
		Helpful:	7
		Not Helpful:	1
Staff ID	Client ID	Comments	Created Date
	DY00184	You received the following feedback From: dy00184 - Shane Hoye Email Address: shoye@hillintltrucks.com Job Classification: SE006, Service Foreman Dealer: HILL INTL TRUCKS NA LLC Feedback: You need to change this because if a 1922 code Is present you are not to attempt a stationary regen.	11/27/2017 9:13:38 AM

Copyright © 2017 Navistar, Inc.