

Authorized Field Change



AFC 17908

Date: November 2017

Subject File: Uptime Improvements

Subject: Update Instrument Cluster, Body Control Module (BCM), Light Control Module (LCM), Switch Pack Modules, Stalk Shifter Module, and Inspection of Powertrain Harness Routing.

Model: Certain International® LT™ Series and International® RH™ Series model trucks.
Start Date: 07 July 2017 End Date: 12 August 2017

DESCRIPTION

Multiple system module updates to mitigate false malfunction indicator light, and inspection of powertrain harness routing.

ELIGIBILITY

This procedure applies ONLY to vehicles marked in the International® Service PortalSM with AFC 17908. Check and complete any other open campaigns also at this time.

TOOLS INFORMATION

Table 1. **Tools Information**

Tool Number	Tool Description
N/A	EZ-Tech® or EST with Diamond Logic® Builder Software

PARTS INFORMATION

Table 2. **Parts Information**

Part Number	Description	Quantity
306132C1	Tie Straps	10 (As Needed)
3554554C1	Guide, BRK Hose & Cable	2 (If Needed)
3820913C91	Strap	1 (If Needed)
3553742C1	Guide, BRK Hose & Cable	1 (If Needed)
25519R1	Nut	1 (If Needed)
25483R1	Bolt	1 (If Needed)
1687803C1	Extension	1 (If Needed)

SERVICE PROCEDURE

 **WARNING:** To prevent property damage, personal injury, and / or death, park vehicle on hard flat surface, turn the engine off, set the parking brake, and install wheel chocks to prevent the vehicle from moving in both directions.

 **WARNING:** To prevent personal injury and / or death, always wear safe eye protection when performing vehicle maintenance.

 **WARNING:** To prevent property damage, personal injury, and /or death, remove ground cable from negative terminal of main battery before disconnecting or connecting electrical components. Always connect ground cable last.

1. Park vehicle on flat surface.
2. Shift transmission to Park or Neutral and set parking brake.
3. Install wheel chocks.

DLB MODULE UPDATES

4. Ensure that current Health Report of the vehicle has been captured.
5. Launch Diamond Logic® Builder (DLB) software and ensure that the vehicle's VIN does not appear in the list of VINs on the Select tab. Delete the VIN if necessary.

NOTE: Use the Nexiq USB link or Nexiq USB Link 2 interface cable for these updates. Other interface cables may increase programming time or may not work at all.

6. With the ignition in the Key ON, Engine OFF position, connect to DLB and let it detect the vehicle's modules.

SERVICE PROCEDURE (CONT.)

The screenshot shows the 'Detected Modules' tab in the software. The main table lists various modules and their status. A right-click context menu is open over the 'Detected...' and 'Kernel' columns, with the 'Kernel' option selected. Three callout numbers are present: '1' points to the 'Detected Modules' tab, '2' points to the column headings in the context menu, and '3' points to the 'Detected...' and 'Kernel' columns in the main table.

Y VIN/Name	Te...	Conf...	Status	Description
2013 N13 Stand	✓		49	
3HSDZAPR7HN505545			43	
HN71379 Base	✓		34	
HN7139 Base BU	✓		32	
LT Backup	✓		24	
LT Temp for Bill	✓		19	
LT test before	✓		11	
TESTVIN01XX144323	✓		4	
Temp for Bill	✓		20	
Wig Wag I/O	✓		11	
fthdytdsyj	✓		20	
play rpm	✓		33	
remove 595BLN	✓		10	Wig Wag

Selected Vehicle	Detected
3HSDZAPR7HN505545	3HSDZAPR7HN505545

Y Module	Add...	Data Link	In C...	Har...	C...	Data V...	Detected...	Kernel
Lighting Control M...	55	Driv...	✓		0	0...	15	15
Six Position Switc...	151	Driv...	✓		0	0...	15	15
Six Position Switc...	152	Driv...	✓		0	0...	15	15
Six Position Switc...	153	Driv...	✓		0	0...	15	15
Six Position Switc...	154	Driv...	✓		0	0...	15	15
Stalk Shifter	5	Driv...	✓		0	0...	52	52

Selected Module	Detected
Instrument Cluster	Instrument Cluster
0	0
0	0
0	0
30101	30101

Figure 1. Detected Modules: Before Update

1. Detected Modules tab
2. Column headings
3. Detected and Kernel columns

NOTE: Only modules that are installed on the connected vehicle will show up on the Detected Modules tab.

NOTE: There may be as many as five switch packs installed on the vehicle. Ensure that all installed switch packs are detected.

NOTE: Vehicles equipped with Stalk Shifter: If stalk shifter is not communicating with the data link or in a non-programmable state before or after performing this update, remove the Transmission Shifter Fuse for 5 seconds, then reinstall to restore module communication.

7. Select the Detected Modules tab (Figure 1, Item 1) to see the kernel information for this vehicle.
8. If the Detected Kernel and Kernel columns are not displayed, enable their display by right clicking on any column heading (Figure 1, Item 2) and then selecting these columns in the right-click menu.

SERVICE PROCEDURE (CONT.)

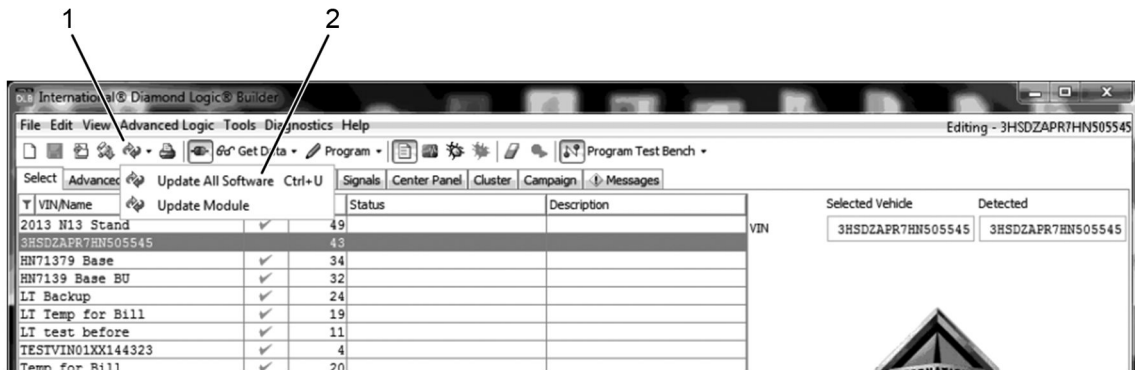

0000428647

Figure 2. Update All

1. Update All icon
2. Update All Software

9. Click the Update All icon in the toolbar (Figure 2, Item 1) and select the Update All Software option (Figure 2, Item 2). DLB will update the versions displayed in the Kernel column to the latest versions available.

SERVICE PROCEDURE (CONT.)

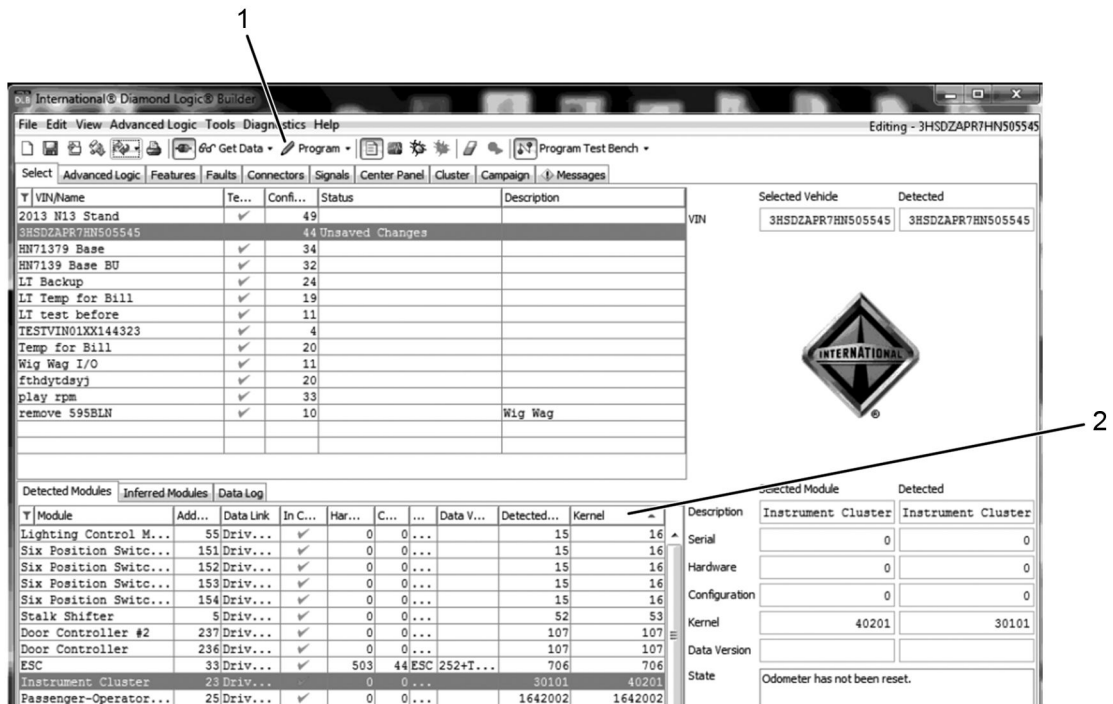

0000428643

Figure 3. Detected Modules: After Update

1. Program icon
2. Kernel column

NOTE: Depending on the number of modules to be programmed, programming could take as long as 60 minutes, during which time the headlights will turn on and off several times. Connecting a battery charger and / or disconnecting the headlights is recommended. Also ensure that your EZ-Tech® battery has sufficient charge to last for the entire procedure.

NOTE: Kernel versions shown in this document's figures are examples only. The actual kernel version that is current when an update is performed may vary.

10. Once the versions in the Kernel column (Figure 3, Item 2) have been updated, click the Program icon (Figure 3, Item 1) in the toolbar.
11. At this point, several messages regarding programming of the body controller may be displayed. Respond to these prompts in the same way you would during normal body controller programming.
12. Once programming begins, DLB will indicate programming status in the status bar at the bottom of the window. Programming may take up to 60 minutes, depending on how many modules are being updated.

SERVICE PROCEDURE (CONT.)

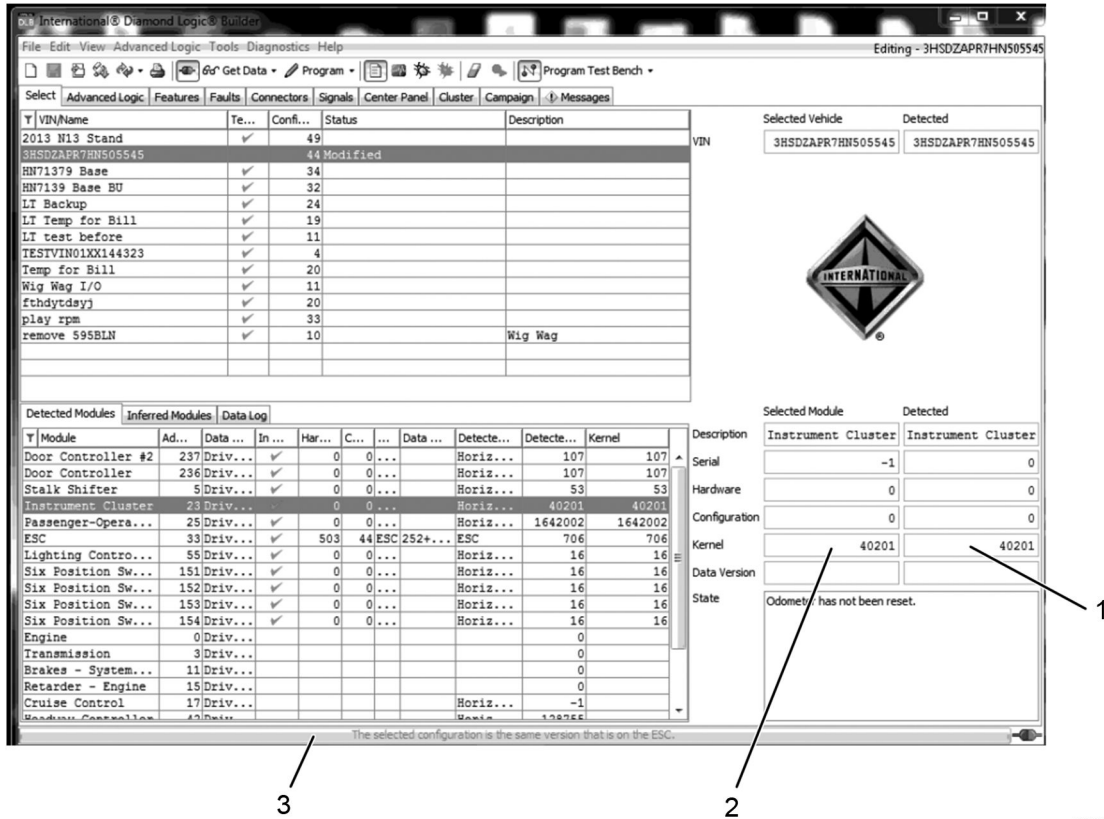

Figure 4. Programming Complete

1. Detected kernel version
2. Selected Module kernel version
3. Status bar

NOTE: During programming, there will not be any prompts that require a technician response. The technician does not need to be present and can perform other tasks while programming is underway.

NOTE: There may be pauses during the update process. Ensure that programming is complete before disconnecting the computer.

13. Verify that programming is complete by selecting each updated module. If the update has been finished for the selected module, the kernel version listed in the Selected Module column (Figure 4, Item 2) will match the version listed in the Detected column (Figure 4, Item 1). Additionally, the status bar at the bottom of the window (Figure 4, Item 3) will display “The selected configuration is the same that is on the ESC.”
14. Disconnect DLB from vehicle by clicking on Disconnect icon, switching vehicle ignition to Key OFF, Engine OFF position, and disconnecting the interface connector from the diagnostic port.
15. Reconnect interface connector to diagnostic port, switch vehicle ignition to Key ON, Engine OFF position and click DLB’s connect icon.

SERVICE PROCEDURE (CONT.)

16. Enter diagnostic mode.
17. Select the Faults tab.
18. Clear any DTCs listed. Refer to the Diamond Logic Builder User Guide for detailed instructions.

NOTE: You may have to invoke the Clear DTCs routine several time to clear all DTCs. Active DTCs will reappear and the issues causing them should be corrected before releasing the vehicle to the customer.

19. Disconnect DLB from vehicle by clicking on Disconnect icon, switching vehicle ignition to Key OFF, Engine OFF position, and disconnecting the interface connector from the diagnostic port.

POWERTRAIN HARNESS

20. Unlatch and open hood.
21. Locate powertrain harness near air compressor discharge line and left engine mount.
22. Inspect powertrain harness; if harness is not rubbing or not in contact with mount proceed to Step 27.

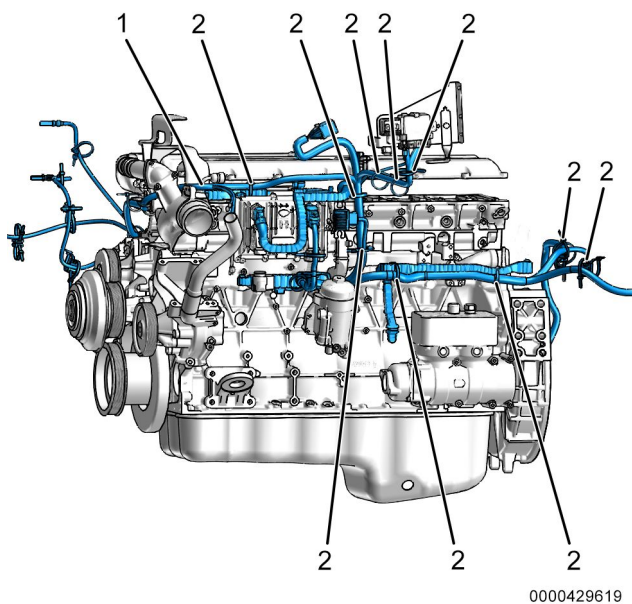
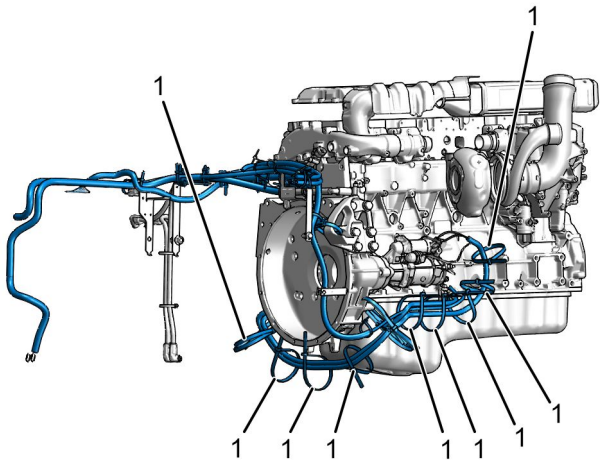

Figure 5. Left-side Tie Strap Locations

1. Harness
2. Tie strap (10)

23. Locate tie strap clips; if tie straps are not installed, adjust harness (Figure 5, Item 1) routing and install tie straps (Figure 5, Item 2). If tie straps are installed, proceed to Step 24.

SERVICE PROCEDURE (CONT.)



0000429618

Figure 6. Rear Tie Strap Locations

1. Tie strap clip (9)

24. Locate tie strap clips (Figure 6, Item 1) on harness underneath turbocharger; if tie straps are not installed, adjust harness routing and install tie straps.

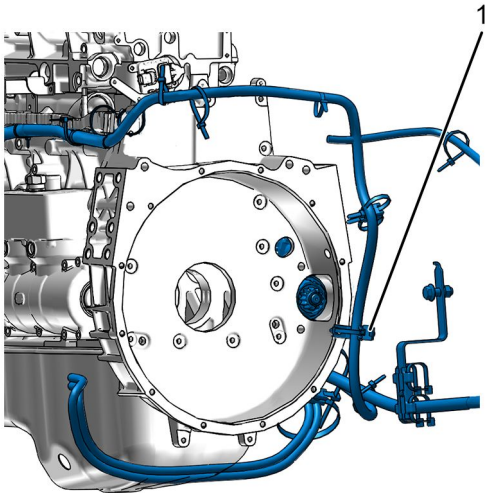

0000429620

Figure 7. LT Rear Bracket

1. Bracket

25. On LT™ Series vehicle, locate rear bracket (Figure 7, Item 1) and secure harness to bracket.

SERVICE PROCEDURE (CONT.)

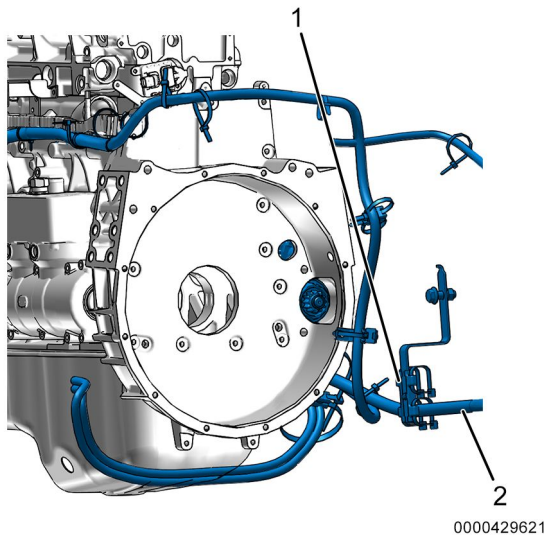

Figure 8. RH Rear Bracket

1. Clip point
2. Starter wire

26. On RH™ Series vehicles or units with frame rail battery boxes, locate clip point (Figure 8, Item 1). If missing, secure powertrain harness to starter wire (Figure 8, Item 2).

27. Close and latch hood.

28. Remove wheel chocks.

LABOR INFORMATION

Operation number must appear on all claims.

Table 3. Labor Information

Operation No.	Description	Time
A40-17908-1	Uptime Improvements	1.0 hr

ADMINISTRATIVE PROCEDURE

Expense is to be charged to Warranty. Claims are to be submitted in the normal manner, making reference to Authorized Field Change Number 17908.

Section 7 of the Warranty Policy and Procedures Manual contains further information related to the submission and processing of AFC / Recall claims.

As with all claim submissions, items acquired locally must be submitted in the “Other Charges” tab. The cost of any bulk items (such as a bag of cable tie straps, roll of wire, barrel of oil, or tube of silicone) should be prorated for the cost of the individual pieces / amount used during each repair.

To ensure this important improvement is made in a timely manner, all claims for 17908 activity must be submitted by 17 November 2018 or within the normal warranty period for the vehicle, if after 17 November 2018.

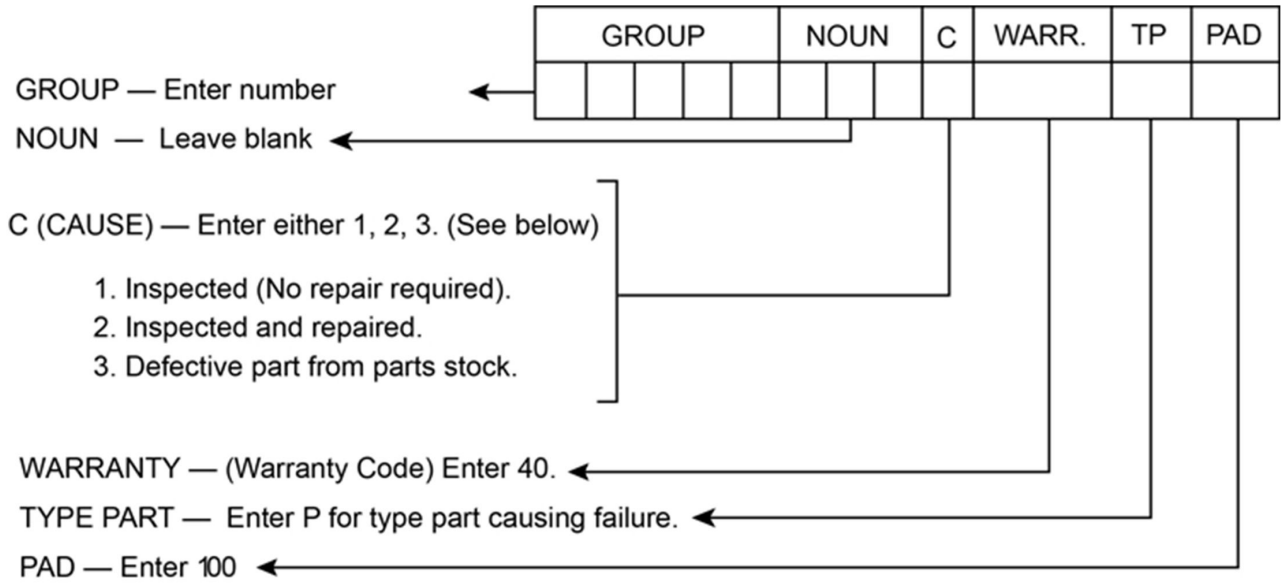

0000047910