



RECREATIONAL VEHICLE SERVICE CAMPAIGN

October 4, 2017

SERVICE ADVISORY 17-298

«Dealer_name»
ATTN: Service Manager
«Street»
«Street_2»
«City», «State» «Zip»
«Country»

Dear «Dealer_name»,

Reason for this campaign It has been determined some 2018 Springdale 38BH models were built with support that may be inadequate for the rear upper bunks, additional support must be added.

The campaign population includes:

2018 Springdale 38BH Travel Trailer
Serial Number Range: H3102471– H3104146

Our records indicate unit(s) sold or in your present lot inventory fall within this range, which will require inspection. **Important:** Please complete the service campaign on these units before retail delivery. Our records indicate the following unit serial number(s) are presently in your inventory or have been sold:

«VIN1»

-- Serial numbers with '*' have been retail sold --

We apologize for any inconvenience this situation may cause and greatly appreciate your cooperation. Should you have any questions or concerns regarding this correspondence or the enclosed Service Advisory, please contact us at: **(866) 273-1452**

Sincerely,

KEYSTONE RV COMPANY

Rick Deisler
Vice President Service Operations

PO Box 2000 Goshen, IN 46527-2000
Phone: (574) 535-2100 – Fax: (574) 535-2199
www.keystonerv.com



RECREATIONAL VEHICLE SERVICE CAMPAIGN

October 4, 2017

Service Advisory: 17-298

SERVICE CAMPAIGN

«Owner_name»
«Street»
«Street_2»
«City», «State» «Zip»
«Country»

VIN: «VIN»

Dear «Owner_name»:

Keystone RV Company is conducting a service campaign on certain 2018 Springdale Travel Trailers. We apologize for any inconvenience this action may cause you; however your continued satisfaction is of the utmost importance to us.

Reason for this campaign

It has been determined some 2018 Springdale 38BH models were built with support that may be inadequate for the rear upper bunks, additional support must be added.

What we will do

Keystone has notified our dealers regarding this situation. The remedy is to install additional fasteners. The service required for this corrective action will be provided at no charge to you.

What we need you to do

At your earliest convenience, please make an appointment to have your RV serviced by your dealership. The labor time to perform this campaign is approximately ½ hour. Please ask your dealer if you wish to know how much additional time will be needed to schedule and process your RV for this repair.

If you have questions

Your dealer is best equipped to obtain parts and provide service to ensure your RV is corrected as promptly as possible. If your dealer is unable to assist or if you take your RV to your dealer on the agreed service date, and the dealer does not remedy the condition within a reasonable amount of time, or without charge to you, please contact Keystone Customer Service by calling 1-866-425-4369.

Thank you for your attention and cooperation in this matter.

Sincerely,

KEYSTONE RV COMPANY

Rick Deisler
Vice President Service Operations

PO Box 2000 Goshen, IN 46527-2000
Phone: (574) 535-2100 – Fax: (574) 535-2199
www.keystonerv.com

SERVICE ADVISORY # 17-298

Springdale 38BH Bunk Support

It has been determined some 2018 Springdale 38BH models were built with support that may be inadequate for the rear upper bunks, additional support must be added. This service advisory explains how to add additional fasteners.

- Models Included:** 2018 Springdale 38BH Travel Trailer
- Serial Number Range:** H3102471– H3104146
- Parts Required:** (10) 2" washer head screws (obtain locally)
(1) 270010 - Trim - Metal - 1" x 1" x 12' - Punched Angle - 1 Leg - Black
- Tools Required:** - Screw Gun with #2 Square Bit

Note – Check serial number on Key Express to verify the campaign is open.

When performing warranty or recall service, please make certain that appropriate Personal Protective Equipment (PPE) is used.

REPAIR INSTRUCTIONS

Step 1

Locate the trailer on a level, flat, hard surface. Chock the wheels.

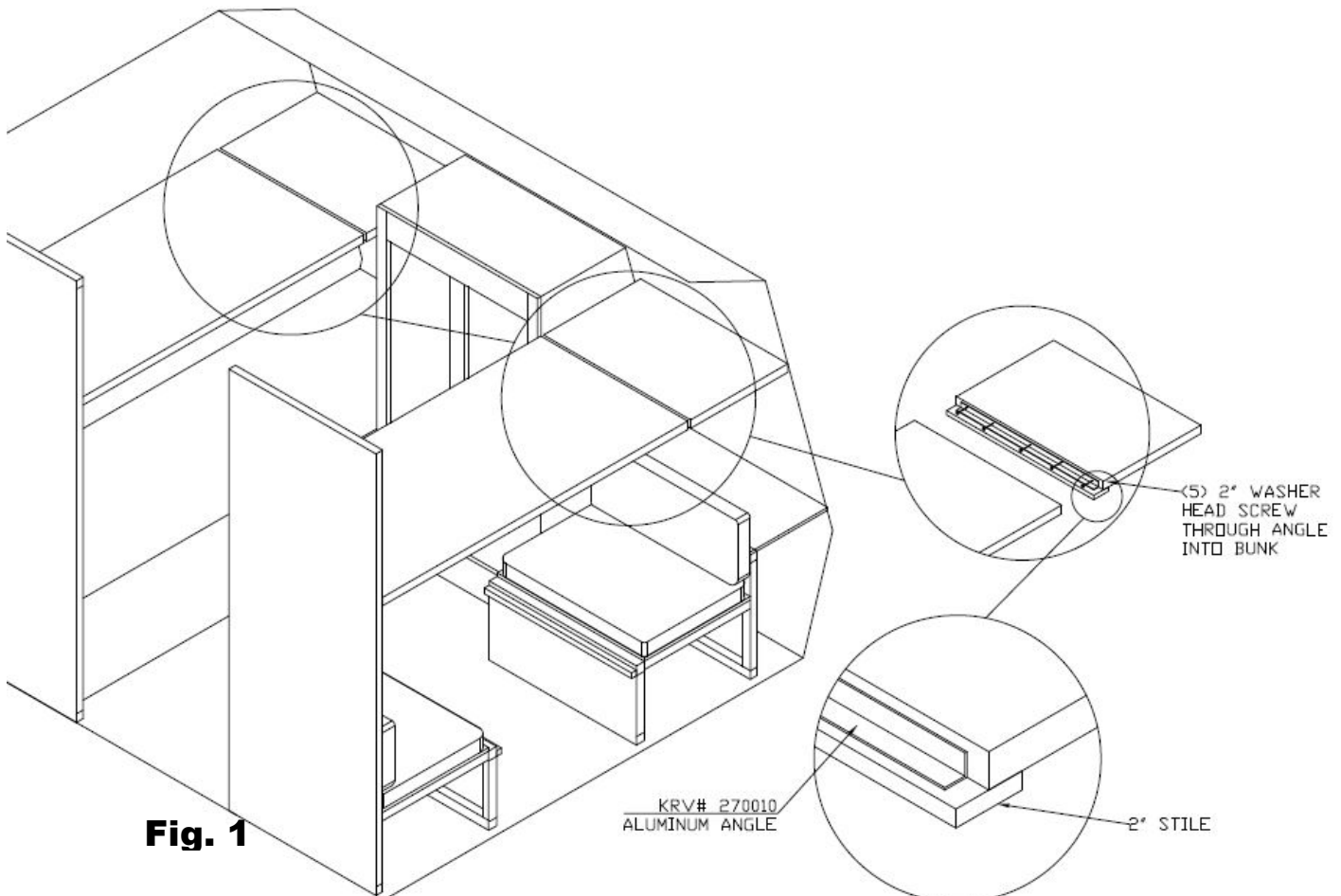

Step 2

Locate the support for the upper bunks in the rear of the unit, Figure 1.

Step 3

Cut aluminum angle (270010) to fit existing support and install according to Figure 1, using 5 screws in each support as indicated.

WARRANTY REIMBURSEMENT

Submit the claim on Key Express using **Flat Rate Code # 7129842A** with **Service Advisory # 17-298** noted in the customer complaint section of the form. The amount of time authorized for this repair is .5 hours.

Please call Keystone Customer Service at **(866) 273-1452** if you have any questions.