

LTB01094NAS1



TECHNICAL BULLETIN

07 SEP 2017

© Jaguar Land Rover North America, LLC

NOTE: The information in Technical Bulletins is intended for use by trained, professional Technicians with the knowledge, tools, and equipment required to do the job properly and safely. It informs these Technicians of conditions that may occur on some vehicles, or provides information that could assist in proper vehicle service. The procedures should not be performed by 'do-it-yourselfers'. If you are not a Retailer, do not assume that a condition described affects your vehicle. Contact an authorized Land Rover service facility to determine whether this bulletin applies to a specific vehicle.

INFORMATION

SECTION:

501-10: Seating

SUBJECT/CONCERN:

Third Row Left Seatback Does Not Fold

AFFECTED VEHICLE RANGE:

MODEL:	MODEL YEAR:	VIN:	ASSEMBLY PLANT:	APPLICABILITY:

MODEL:	MODEL YEAR:	VIN:	ASSEMBLY PLANT:	APPLICABILITY:
Discovery (LR)	2017 Onwards	000532 Onwards	Solihull	Vehicles With: 7 Seats

MARKETS:

NORTH AMERICA

CONDITION SUMMARY:

SITUATION:

When operating the third row seat intelligent seat fold feature, the left seatback may fold down and then return to the raised position.

CAUSE:

This may be caused by the seat cushion cover activating the anti-trap sensor.

ACTION:

Should a customer express this concern, follow the Service Instruction below.

PARTS:

NOTE:

An allowance (\$1.25 USD [or local equivalent]) has been provided to cover the cost of the double-sided tape. Claim using Sundry Code 'ZZZ001'.

PART NUMBER	DESCRIPTION	QUANTITY:
LR057150	Hog ring	22
ZZZ001	Double-sided tape (locally sourced)	£1

TOOLS:

Refer to Workshop Manual for any required special tools.

WARRANTY:**NOTES:**

- Repair procedures are under constant review, and therefore times are subject to change; those quoted here must be taken as guidance only. Always refer to TOPIx to obtain the latest repair time.
- The JLR Claims Submission System requires the use of causal part numbers. Labor only claims must show the causal part number with a quantity of zero

DESCRIPTION	SRO	TIME (HOURS)	CONDITION CODE	CAUSAL PART
Third row seat anti-trap sensor - Modification	78.40.89.28	0.4	42	LR080975

NOTE:

Normal Warranty procedures apply.

SERVICE INSTRUCTION:

1

CAUTION:

The third row left seat cushion cover must be fully removed to complete this repair. Failure to do so may damage or crease the cover.

Remove the third row left seat cushion cover (see TOPIx Workshop Manual section 501-10: Seating - Removal and Installation - Third row seat cushion cover).

2

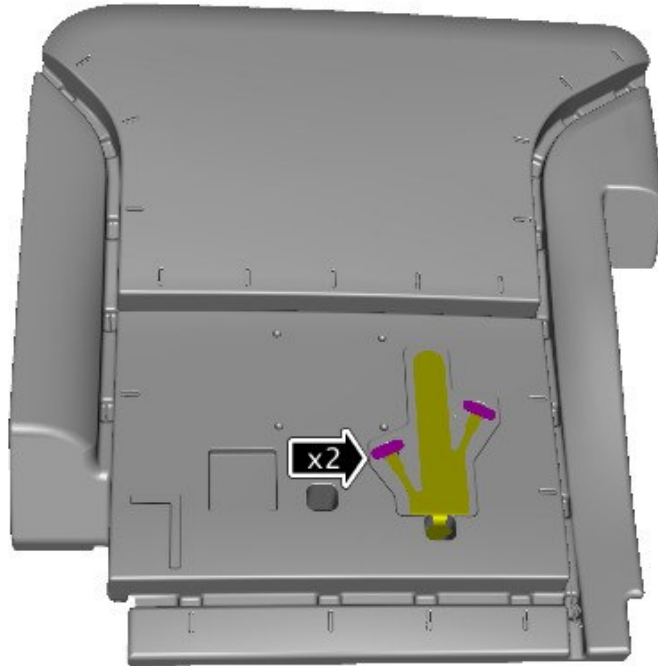

E212915

Release the 2 anti-trap sensor locating tabs from the seat cushion.

3

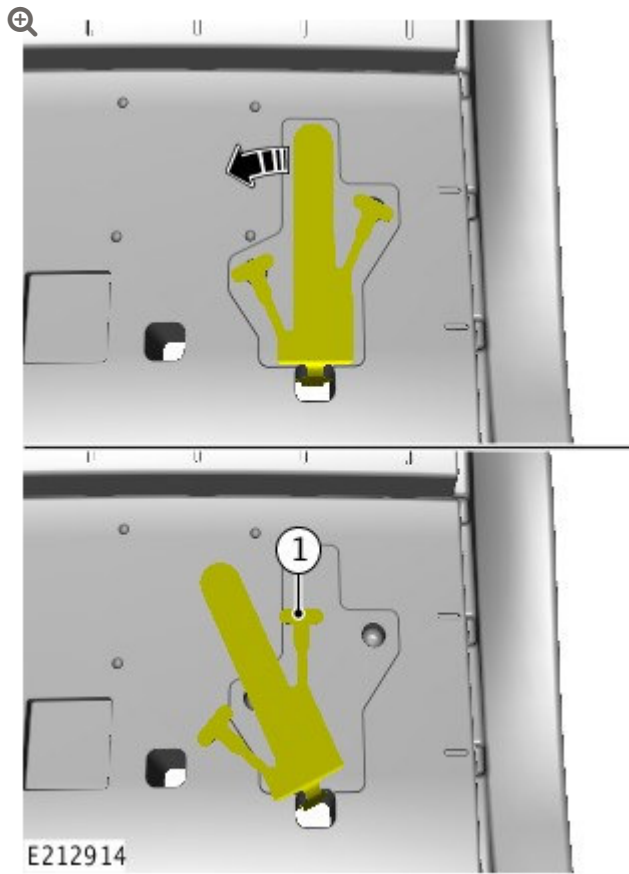

Position the anti-trap sensor so that locating tab (1) is oriented as shown.

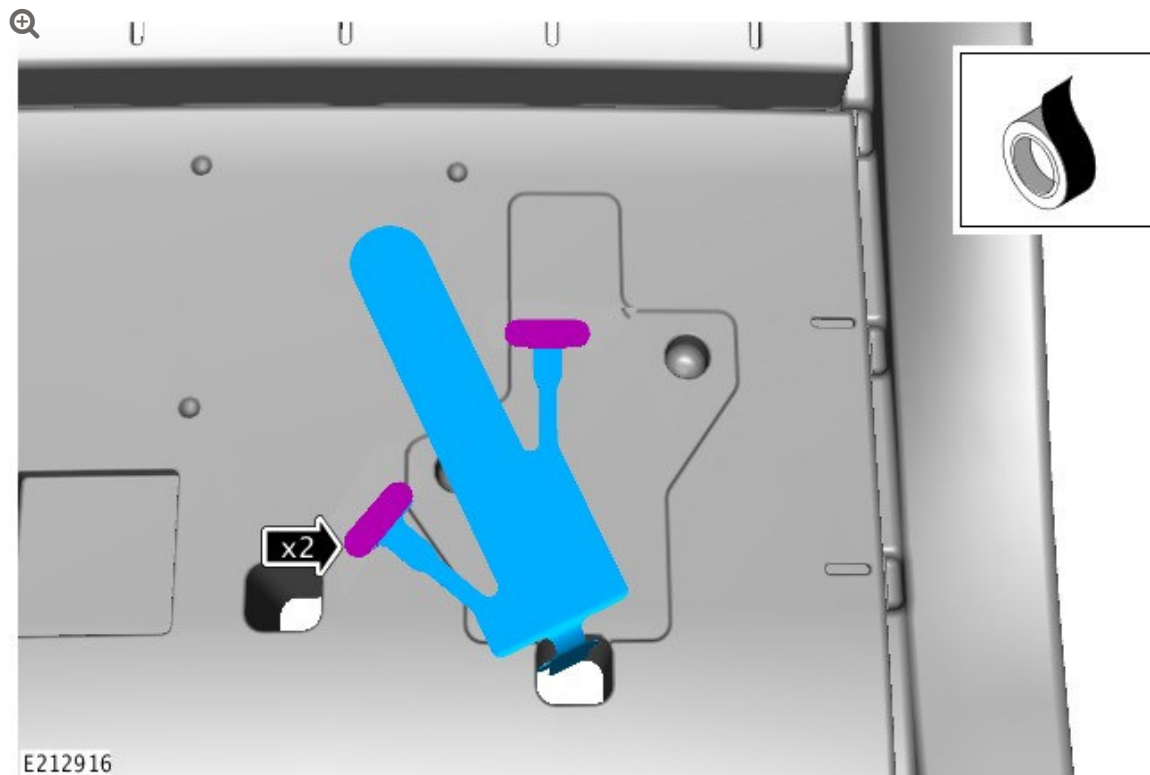

Install the anti-trap sensor using appropriate double-sided tape under the locating tabs as shown.

5

NOTE:

Make sure the anti-trap sensor does not contact the seat cushion cover seam.

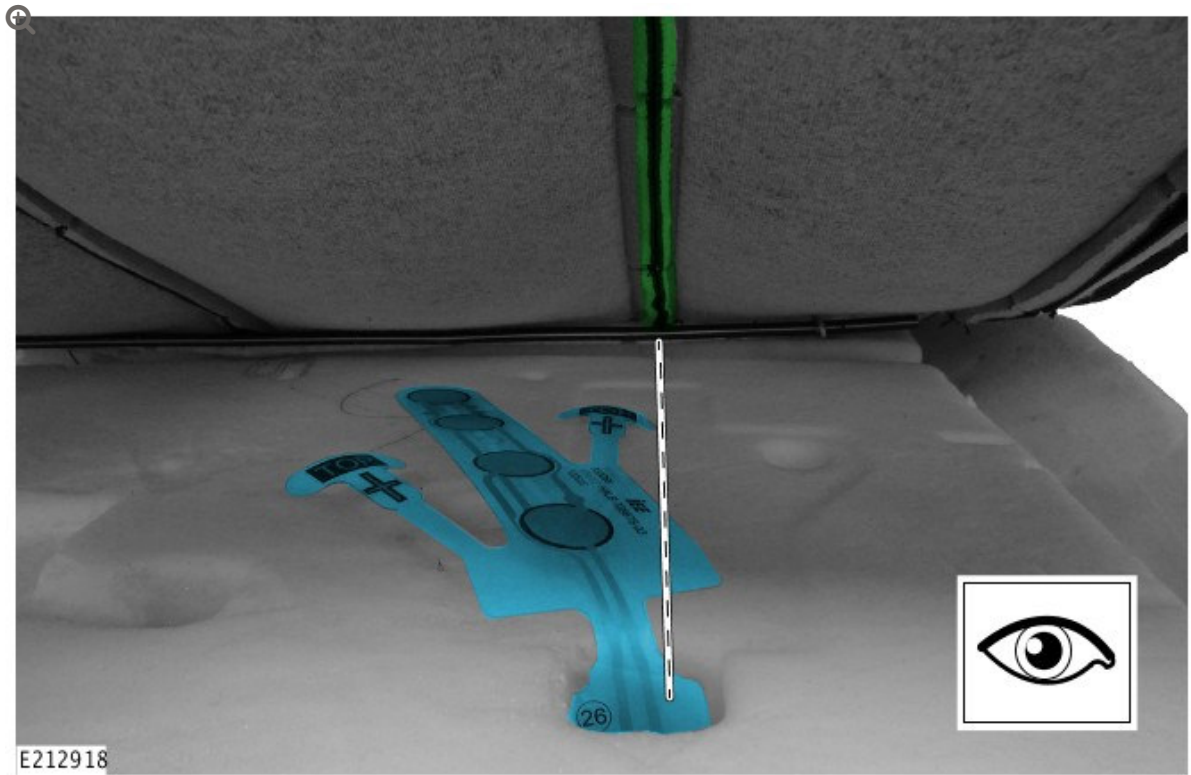

Install the third row left seat cushion cover (see TOPIx Workshop Manual section 501-10: Seating - Removal and Installation - Third row seat cushion cover).