

<b>REFERENCE:</b>	Nova Bus Manuals
<b>SECTION:</b>	12: Interior Furnishings
<b>RS N°:</b>	MQR 7621-849
<b>EFFECTIVE IN PROD.:</b>	N/A

**APPLICATION DEADLINE:** 2019JA31  
**CLAIM REFERENCE NUMBER:** WB-3448

<b>SUBJECT:</b>	Bum rest shells replacement
<b>JUSTIFICATION:</b>	Bum rest shells cracking and anchor points may loosen with time and vibration.

LEVEL	DESCRIPTION	DIRECT CHARGES		TIME
		LABOUR	MATERIAL	
1	Bushing added to prevent torquing of bolt directly on the shell.	Nova Bus	Nova Bus	2 h
2	–	–	–	–

**MATERIAL**

QTY	PART N°	REV.	DESCRIPTION	REPLACES PART N°
<b>LEVEL 1</b>				
1	N81705	–	SHELL REAR (CUT OUT)	N58090
1	N81704	–	SHELL FRONT (CUT OUT)	N74699
8	N31991	–	UPPER BOLT PAD M6 X 50 SS GR.A2 DIN 931	–
1	N35535-01	–	SIKAFLEX 552 AEROGRAY DARK/400	–
7	N81726	–	SCREW M12X75 HEX SS CL A2-70	–
7	N8902765	–	BUSHINGS	–
7	N79659	–	WASHER NORD-LOCK M12 O/S OD SS	–
7	N58380	–	GROMMET 1"ID	–
<b>LEVEL 2</b>				
7	N58627	–	CAP PROTECTOR	–
1	N58602	–	GASKET BUM REST	–

Materials will be available within 50 days. To order, please contact Prevost Parts by phone at 1-800-771-6682, by fax at 1-888-668-2555 or by email at [prevostparts.commandes@volvo.com](mailto:prevostparts.commandes@volvo.com). Specify document number, quantity of parts required and shipping address.

**DISPOSAL OF PARTS**

<b>REMOVED PARTS ARE:</b>	<b>DISCARDED *</b>	<b>RETAINED</b>	* Dispose of the unused parts and the defective parts in accordance with local environmental standards in effect.
	Yes	–	

**REVISION HISTORY**

<b>REV.</b>	<b>DATE</b>	<b>CHANGE DESCRIPTION</b>	<b>WRITTEN BY</b>
NR	2015DE02	Initial release	André Pelletier
R1	2017NO23	Revised partlist, procedure, client list and operation time	Kumaraswamy K S

**APPROVED BY:**

Symbol	Meaning
Empty Field	No changes, the procedure applies
+	Contract added, the procedure applies
-	Contract removed, the procedure does not apply

	CLIENT	ORDER	ROAD NUMBER		VIN (2NVY/4RKY...)		QTY
			FROM	TO	FROM	TO	
	Clemson Area Transit - South Carolina	L769	—	—	S92U1D4500418	S92U1D4500418	1
	CT Transit - Connecticut	L814	1462	1473	S92LXE4500717	S92L4E4500728	12
+	Ames Transportation Agency - Iowa	L904	6101	6104	S92J1G9775221	S92J7G9775224	4



**WARNING**

Follow your internal safety procedures.

**PROCEDURE**

1.1. Remove the front and the rear bum rest shells. Retain the removed parts. See Figure 1.

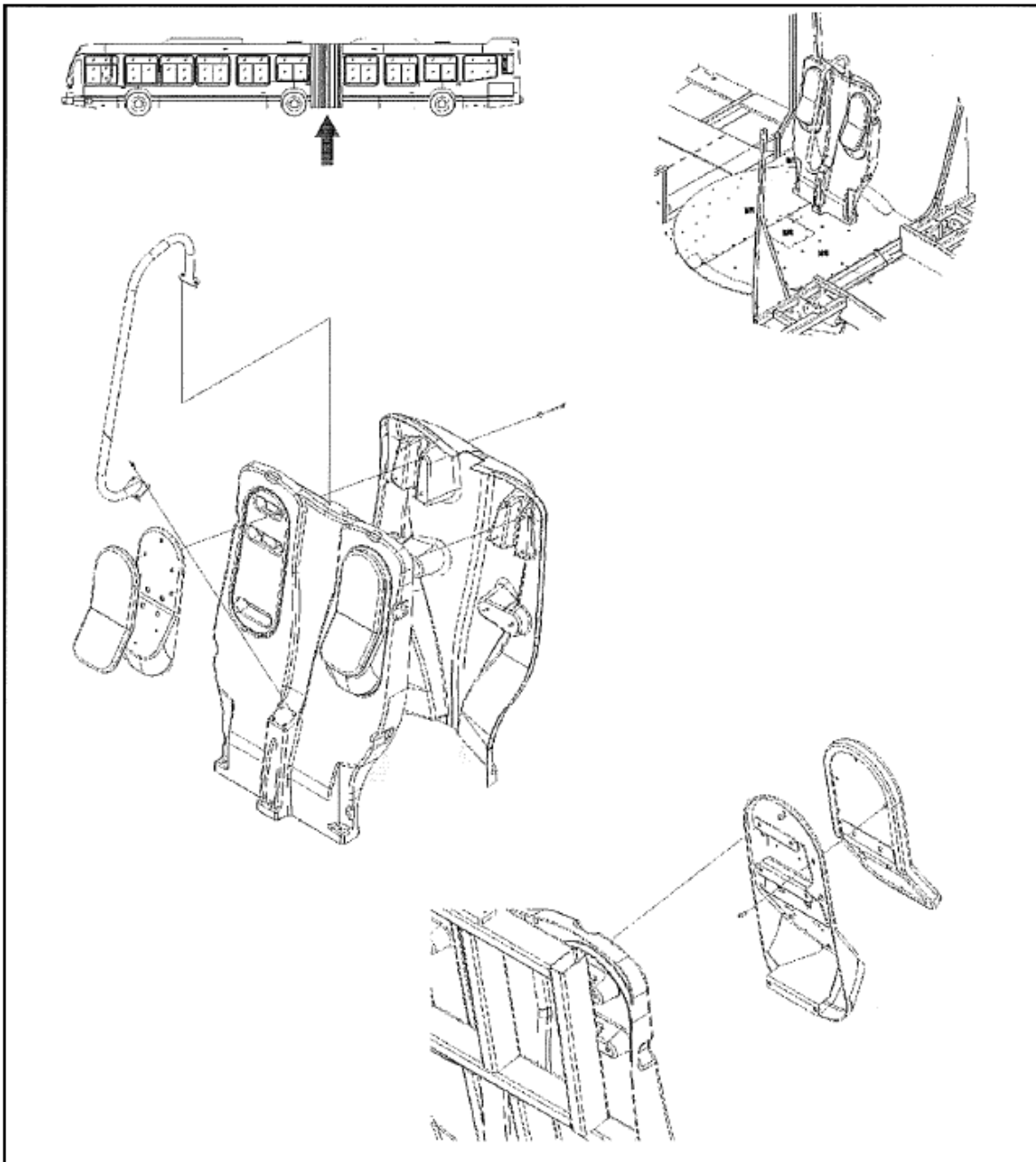

Figure 1 - Front and Rear Bum Rest Views

- 1.2. Enlarge the holes in parts N81704 (3x) and N81705 (4x) to 1.25" in diameter.
- 1.3. Install the new bum rest shells using the rubber grommet N58380, the new bushing N8902765, self-locking washer N79659 and screw N81726. Torque to 30.2 lb-ft (41 N•m). See Figure 2. Typical for 7 locations.

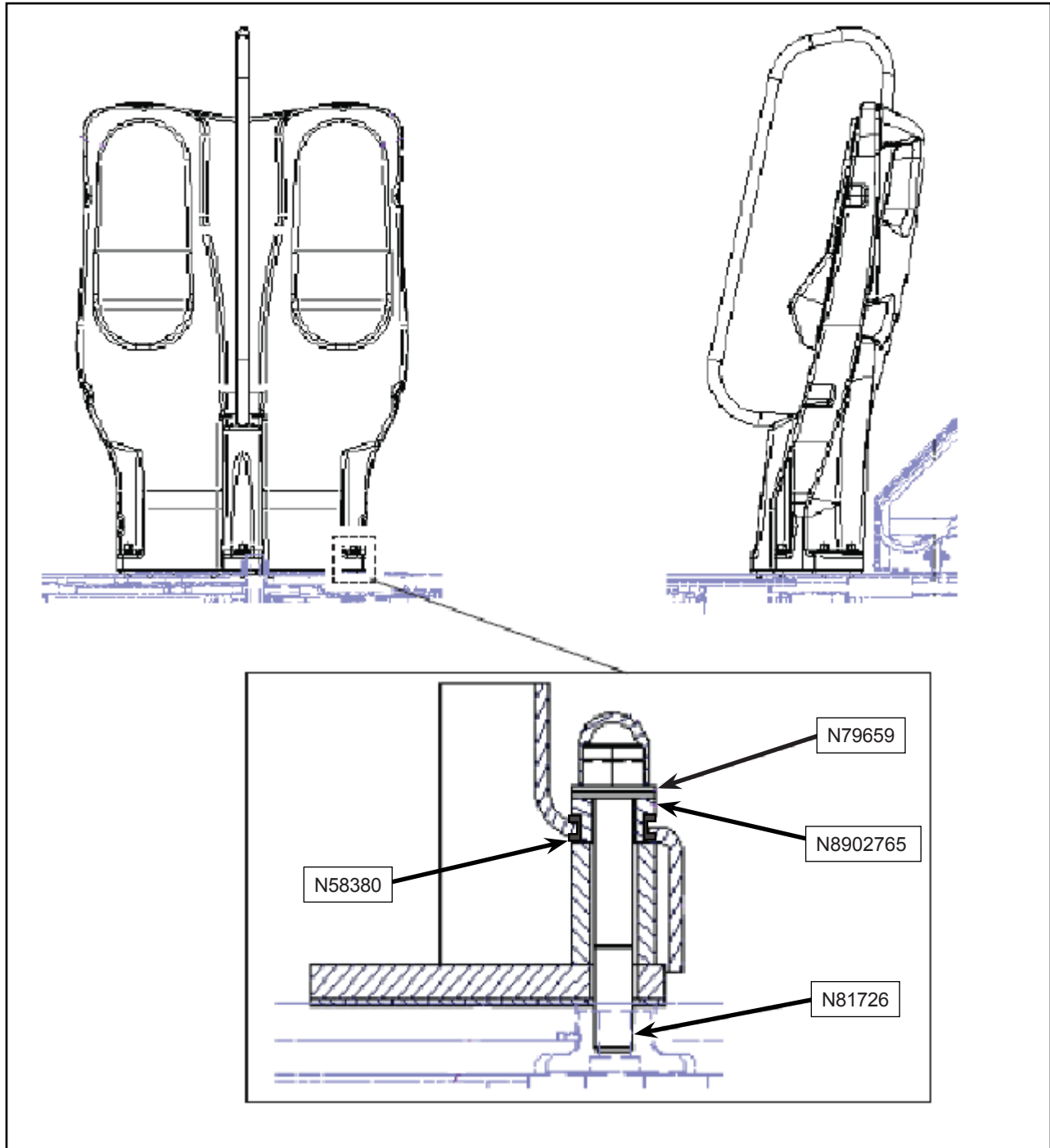

Figure 2 - Hardware Location

- 1.4. Re-install bum rest parts and hardware. New upper pad bolts N31991 are provided.
- 1.5. Apply Sikaflex N35535-01 to make a finishing seam between the rear and the front shell. ❖