



DATE: May 8, 2017

APPLIES TO: This service bulletin applies to the Emergency Response chassis cabs listed below by Model and Model Year, built between March 26, 2004 to August 8, 2016.

Model	Model Year
<u>Advantage</u>	<u>2005 – 2009</u>
<u>Diamond</u>	<u>2004 – 2008</u>
<u>Gladiator</u>	<u>2004 – 2017</u>
<u>MetroStar</u>	<u>2006 – 2017</u>
<u>MetroStar R/T</u>	<u>2010 - 2014</u>

CONDITION: Door hinge may deform causing door to sag.

CORRECTION: Replace door hinges, door latches, strikers and door seals.

LABOR ALLOCATION: 2.5 Hrs. per door.

CLASSIFICATION: E

Service Bulletins are intended for use by Professional Technicians only. They are written to guide Professional Technicians in performing service to vehicles of specific nature in conjunction with industry standards. Professional Technicians should be appropriately trained on industry standards and have the tools and equipment to perform procedures safely and properly.



PARTS NEEDED:

<u>QTY</u>	<u>Part Number</u>	<u>Description</u>
1	S-2587-001C	KIT-SERVICE DOOR HINGE, MFD + FLAT ROOF

Kit # S-2587-001C Contains:

<u>QTY</u>	<u>Part Number</u>	<u>Description</u>
2	67201212	FRONT DOOR HINGE
2	67201213	REAR DOOR HINGE
4	17200723	REINFORCEMENT PLATE
84	61200596	WASHER
2	0533-EE3-001	ASM-LATCH LH
2	0533-EE3-002	ASM-LATCH RH
4	0550-EE3-001	STRIKER-DOOR LATCH
1	0764-EE3	INSTL-DOOR LATCH, FRONT DOORS
1	0253-ZZ4	STRIKER/LATCH PROCESS
48 FT	1249-RR1	D-SEAL
16	0202-BB1-017	SCREW-M6-1.0X16MM TORX DR PAN HD MACH,ZINC,W/THD LOCK
8	M06100FNZ	NUT-FLANGE 6MM X 1.0 ZINC
1	TSB17-110-001	INSTRUCTION DOCUMENT
1	TSB17-110-002	INSTRUCTION DOCUMENT

<u>QTY</u>	<u>Part Number</u>	<u>Description</u>
1	S-2588-001C	KIT-SERVICE DOOR HINGE, MFD + 10" RAISED ROOF

Kit # S-2588-001C Contains:

<u>QTY</u>	<u>Part Number</u>	<u>Description</u>
2	67201212	FRONT DOOR HINGE
2	67201214	REAR DOOR HINGE
4	17200723	REINFORCEMENT PLATE
84	61200596	WASHER
2	0533-EE3-001	ASM-LATCH LH
2	0533-EE3-002	ASM-LATCH RH
4	0550-EE3-001	STRIKER-DOOR LATCH
1	0764-EE3	INSTL-DOOR LATCH, FRONT DOORS
1	0253-ZZ4	STRIKER/LATCH PROCESS
48 FT	1249-RR1	D-SEAL

Service Bulletins are intended for use by Professional Technicians only. They are written to guide Professional Technicians in performing service to vehicles of specific nature in conjunction with industry standards. Professional Technicians should be appropriately trained on industry standards and have the tools and equipment to perform procedures safely and properly.



16	0202-BB1-017	SCREW-M6-1.0X16MM TORX DR PAN HD MACH,ZINC,W/THD LOCK
8	M06100FNZ	NUT-FLANGE 6MM X 1.0 ZINC
1	TSB17-110-001	INSTRUCTION DOCUMENT
1	TSB17-110-002	INSTRUCTION DOCUMENT

<u>QTY</u>	<u>Part Number</u>	<u>Description</u>
1	S-2589-001C	KIT-SERVICE DOOR HINGE, MFD + 20" RAISED ROOF

Kit # S-2589-001C Contains:

<u>QTY</u>	<u>Part Number</u>	<u>Description</u>
2	67201212	FRONT DOOR HINGE
2	67201215	REAR DOOR HINGE
4	17200723	REINFORCEMENT PLATE
90	61200596	WASHER
2	0533-EE3-001	ASM-LATCH LH
2	0533-EE3-002	ASM-LATCH RH
4	0550-EE3-001	STRIKER-DOOR LATCH
1	0764-EE3	INSTL-DOOR LATCH, FRONT DOORS
1	0253-ZZ4	STRIKER/LATCH PROCESS
48 FT	1249-RR1	D-SEAL
16	0202-BB1-017	SCREW-M6-1.0X16MM TORX DR PAN HD MACH,ZINC,W/THD LOCK
8	M06100FNZ	NUT-FLANGE 6MM X 1.0 ZINC
1	TSB17-110-001	INSTRUCTION DOCUMENT
1	TSB17-110-002	INSTRUCTION DOCUMENT

<u>QTY</u>	<u>Part Number</u>	<u>Description</u>
1	S-2590-001C	KIT-SERVICE DOOR HINGE, SMFD FLAT ROOF

Kit # S-2590-001C Contains:

<u>QTY</u>	<u>Part Number</u>	<u>Description</u>
2	67201212	FRONT DOOR HINGE
2	67201224	REAR DOOR HINGE
4	17200723	REINFORCEMENT PLATE
84	61200596	WASHER
2	0533-EE3-001	ASM-LATCH LH

Service Bulletins are intended for use by Professional Technicians only. They are written to guide Professional Technicians in performing service to vehicles of specific nature in conjunction with industry standards. Professional Technicians should be appropriately trained on industry standards and have the tools and equipment to perform procedures safely and properly.



2	0533-EE3-002	ASM-LATCH RH
4	0550-EE3-001	STRIKER-DOOR LATCH
1	0764-EE3	INSTL-DOOR LATCH, FRONT DOORS
1	0253-ZZ4	STRIKER/LATCH PROCESS
48 FT	1249-RR1	D-SEAL
16	0202-BB1-017	SCREW-M6-1.0X16MM TORX DR PAN HD MACH,ZINC,W/THD LOCK
8	M06100FNZ	NUT-FLANGE 6MM X 1.0 ZINC
1	TSB17-110-001	INSTRUCTION DOCUMENT
1	TSB17-110-002	INSTRUCTION DOCUMENT

<u>QTY</u>	<u>Part Number</u>	<u>Description</u>
1	S-2594-001C	KIT-SERVICE DOOR HINGE 2 DOOR CAB

Kit # S-2594-001C Contains:

<u>QTY</u>	<u>Part Number</u>	<u>Description</u>
2	67201212	FRONT DOOR HINGE
4	17200723	REINFORCEMENT PLATE
42	61200596	WASHER
1	0533-EE3-001	ASM-LATCH LH
1	0533-EE3-002	ASM-LATCH RH
2	0550-EE3-001	STRIKER-DOOR LATCH
1	0764-EE3	INSTL-DOOR LATCH, FRONT DOORS
1	0253-ZZ4	STRIKER/LATCH PROCESS
12 FT	1249-RR1	D-SEAL
8	0202-BB1-017	SCREW-M6-1.0X16MM TORX DR PAN HD MACH,ZINC,W/THD LOCK
4	M06100FNZ	NUT-FLANGE 6MM X 1.0 ZINC
1	TSB17-110-001	INSTRUCTION DOCUMENT
1	TSB17-110-002	INSTRUCTION DOCUMENT

Service Bulletins are intended for use by Professional Technicians only. They are written to guide Professional Technicians in performing service to vehicles of specific nature in conjunction with industry standards. Professional Technicians should be appropriately trained on industry standards and have the tools and equipment to perform procedures safely and properly.



GENERAL INSTRUCTIONS:

Thoroughly review entire service bulletin before starting work. If there are questions or concerns with steps defined in this service bulletin, contact Spartan Motors USA, Inc. Customer & Product Support Group.

All applicable industry safety standards **must** be followed when performing work identified in this procedure.

NOTE: This bulletin applies to all cab doors.

STEP-BY-STEP INSTRUCTIONS:

1. Remove door check strap from door. Take care not to allow the door to swing open and hit / damage the side of the cab. Refer to FIG. 5-1.

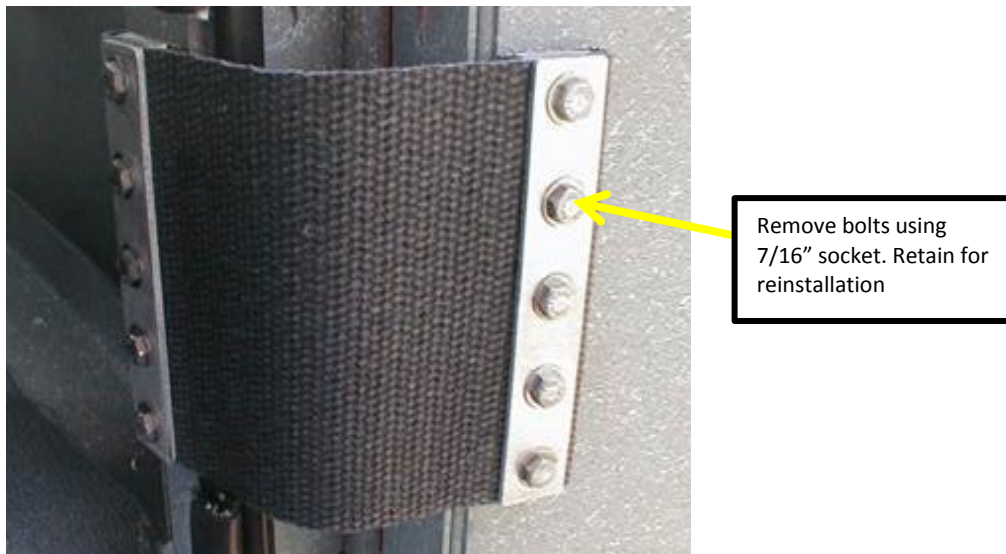

FIG 5-1

2. Roll window all the way down to prevent glass from falling when un-hooked from door panel.
3. Remove door panels. While removing the door panels the window regulator will need to be disconnected from the door glass. Refer to FIG. 6-1, FIG. 6-2 and FIG. 7-1.

Service Bulletins are intended for use by Professional Technicians only. They are written to guide Professional Technicians in performing service to vehicles of specific nature in conjunction with industry standards. Professional Technicians should be appropriately trained on industry standards and have the tools and equipment to perform procedures safely and properly.

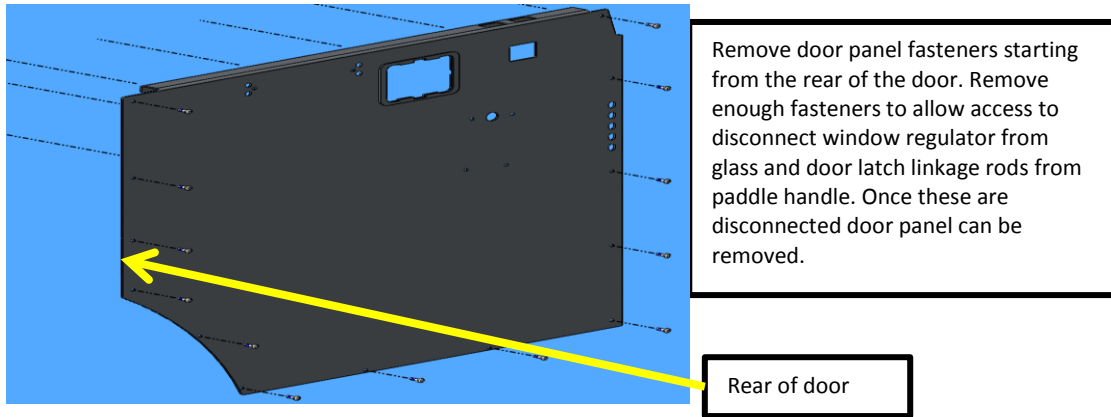

FIG. 6-1

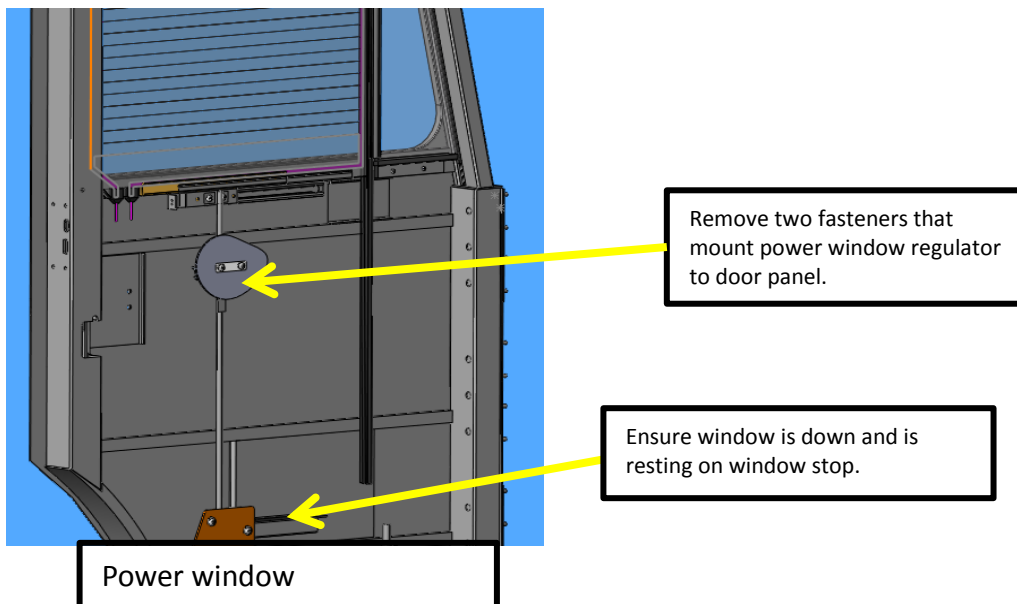
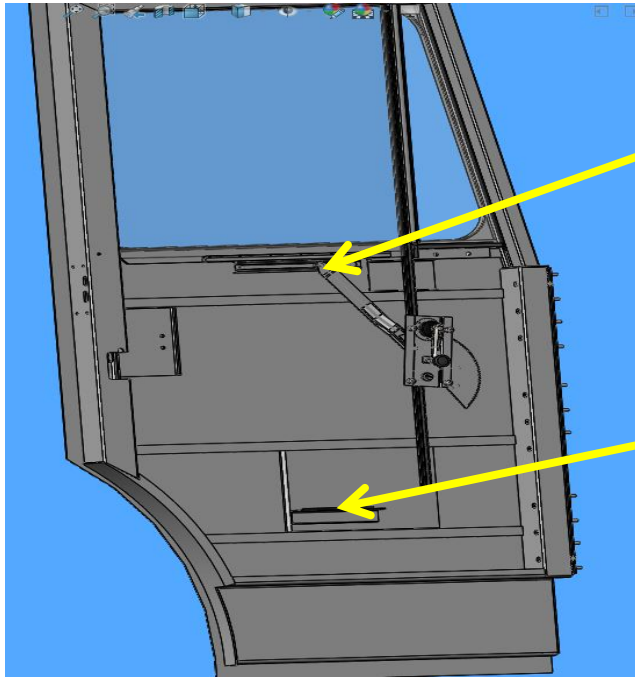

FIG. 6-2

Service Bulletins are intended for use by Professional Technicians only. They are written to guide Professional Technicians in performing service to vehicles of specific nature in conjunction with industry standards. Professional Technicians should be appropriately trained on industry standards and have the tools and equipment to perform procedures safely and properly.



Remove regulator from glass channel in manual window regulator configurations.

Ensure window down is resting on window stop.

Manual Window Configuration

FIG. 7-1

Service Bulletins are intended for use by Professional Technicians only. They are written to guide Professional Technicians in performing service to vehicles of specific nature in conjunction with industry standards. Professional Technicians should be appropriately trained on industry standards and have the tools and equipment to perform procedures safely and properly.



4. For view showing front door with door panel removed. Refer to FIG. 8-1.



Front door shown with door panel removed.

FIG. 8-1

5. While removing the door panels the door latch rods will need to be disconnected. Refer to FIG. 8-2.

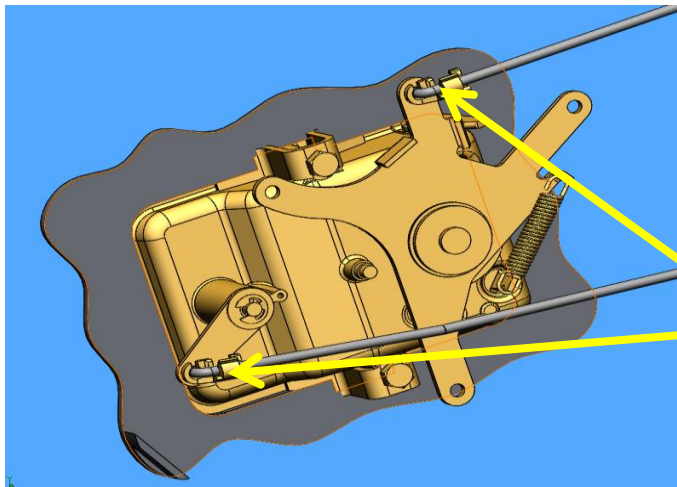

Remove door latch rods from back of paddle handle by pressing the clips off the rods then slide rods out of clips. Ensure clips stay in place on back of paddle handle.

FIG. 8-2

6. While removing the door panels any electrical wires connected to the door panels such as power window switches or door lights will need to be disconnected.

Service Bulletins are intended for use by Professional Technicians only. They are written to guide Professional Technicians in performing service to vehicles of specific nature in conjunction with industry standards. Professional Technicians should be appropriately trained on industry standards and have the tools and equipment to perform procedures safely and properly.



7. Disconnect all wiring that may go through the door hinge for items such as power mirrors (removal of mirror may be necessary to access connector for de-pinning), door lights and power windows. Wire pass through spring(s) will need to be removed and retained for re-use. Refer to FIG. 9-1.

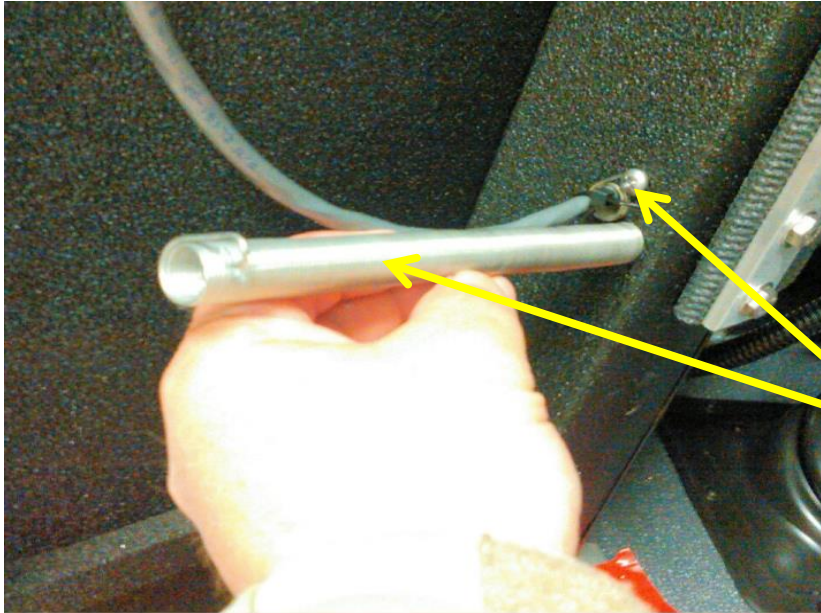

Wire pass through spring. Spring also shown removed.

FIG. 9-1

8. Change door latches and fasteners P.N. 0533-EE3-001, 0533-EE3-002, 0202-BB1-017 and M06100FNZ. Properly dispose of old latches and fasteners. NOTE: two fasteners toward outside of door utilize nuts for mounting. Ensure these do not fall into the door frame when removing or installing. Torque fasteners to 45 lbf-in. Refer to FIG. 10-1, FIG. 10-2 and FIG. 11-1.

Service Bulletins are intended for use by Professional Technicians only. They are written to guide Professional Technicians in performing service to vehicles of specific nature in conjunction with industry standards. Professional Technicians should be appropriately trained on industry standards and have the tools and equipment to perform procedures safely and properly.

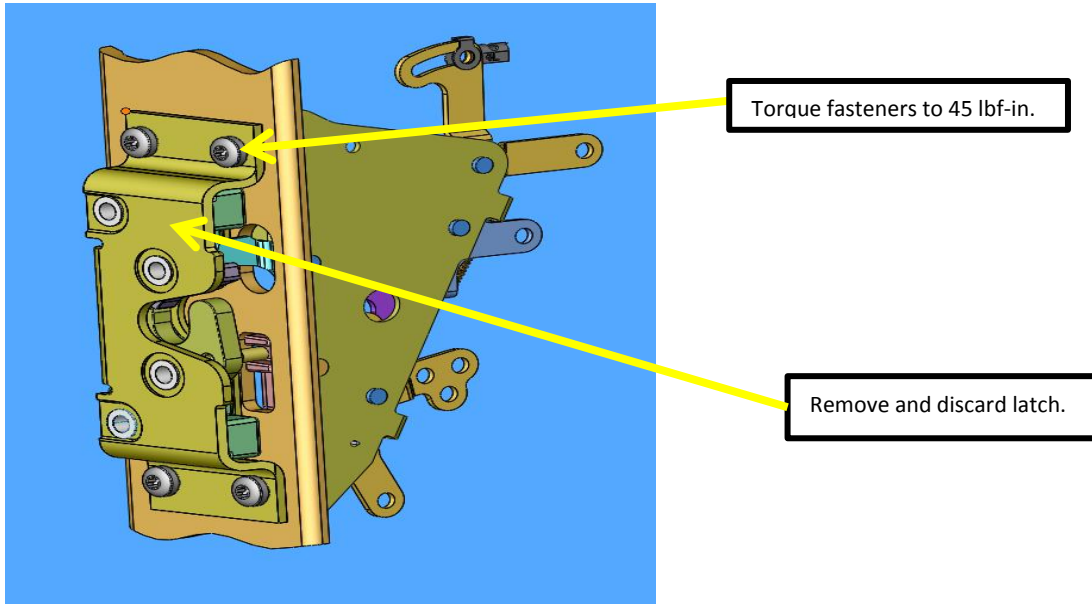

FIG. 10-1

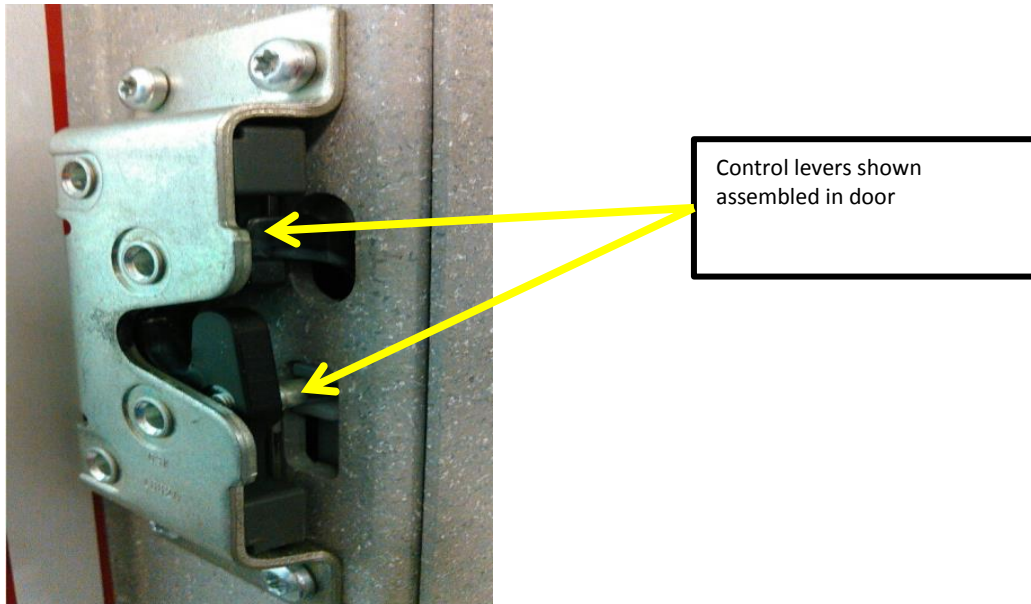
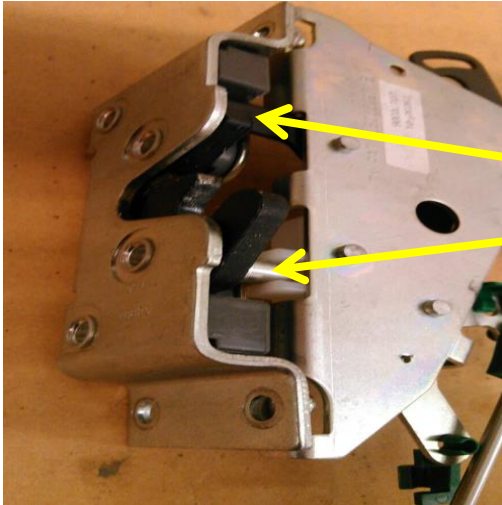

FIG. 10-2

Service Bulletins are intended for use by Professional Technicians only. They are written to guide Professional Technicians in performing service to vehicles of specific nature in conjunction with industry standards. Professional Technicians should be appropriately trained on industry standards and have the tools and equipment to perform procedures safely and properly.



Ensure control levers are engaged properly when assembled. Shown with door removed for better clarity.

FIG. 11-1

9. Change door latch striker P.N. 0550-EE3-001. Once striker is installed and adjusted, it is to be torqued to 56 lbf-ft. Refer to FIG. 11-2.

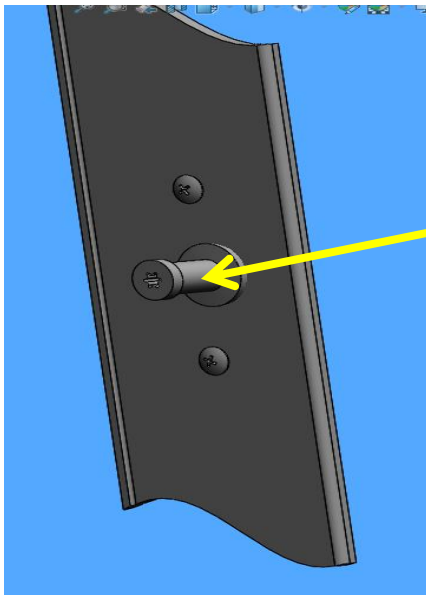

Remove and dispose of striker. Install new striker per 0764-EE3 print and adjust per striker latch process 0253-ZZ4.

FIG. 11-2

10. Support the weight of the door in an opened position in preparation for removing the door hinge. Door weights approximately 150-200 lbs.

Service Bulletins are intended for use by Professional Technicians only. They are written to guide Professional Technicians in performing service to vehicles of specific nature in conjunction with industry standards. Professional Technicians should be appropriately trained on industry standards and have the tools and equipment to perform procedures safely and properly.



11. Once door is supported remove door hinge fasteners. Retain for re-use. Properly dispose of old hinge and washers. Refer to FIG. 12-1.

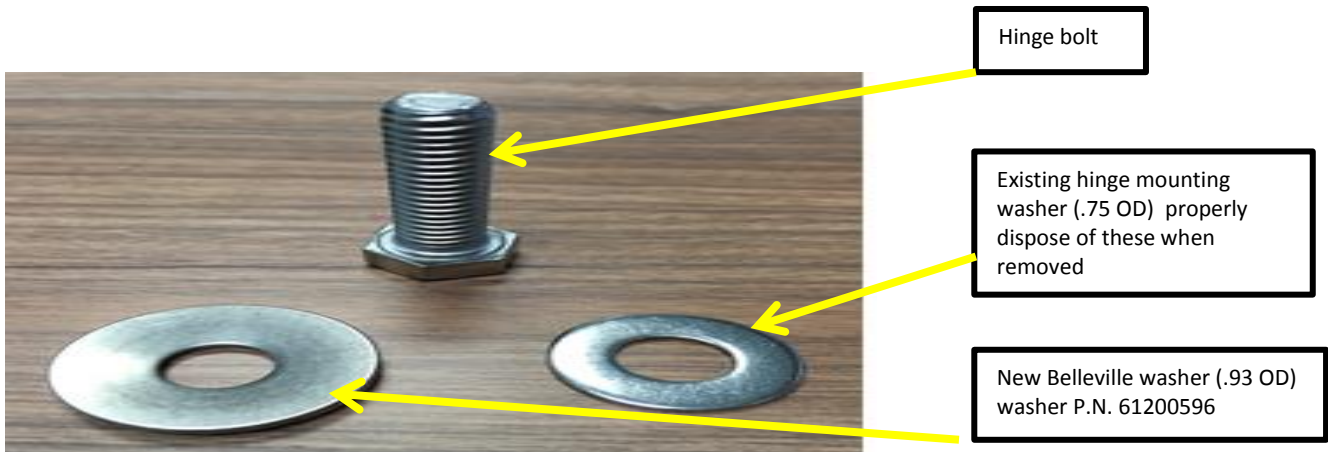

FIG.12-1

12. Ensure that bolts and washers are clean and dry then reinstall new door hinge using retained bolts, new washers, (P.N. 61200596) and (2) reinforcement plates (P.N. 17200723) at each front door. No reinforcement plates required for the rear doors. For proper washer installation Refer to FIG. 12-2, FIG. 13-1 and FIG. 13-2.

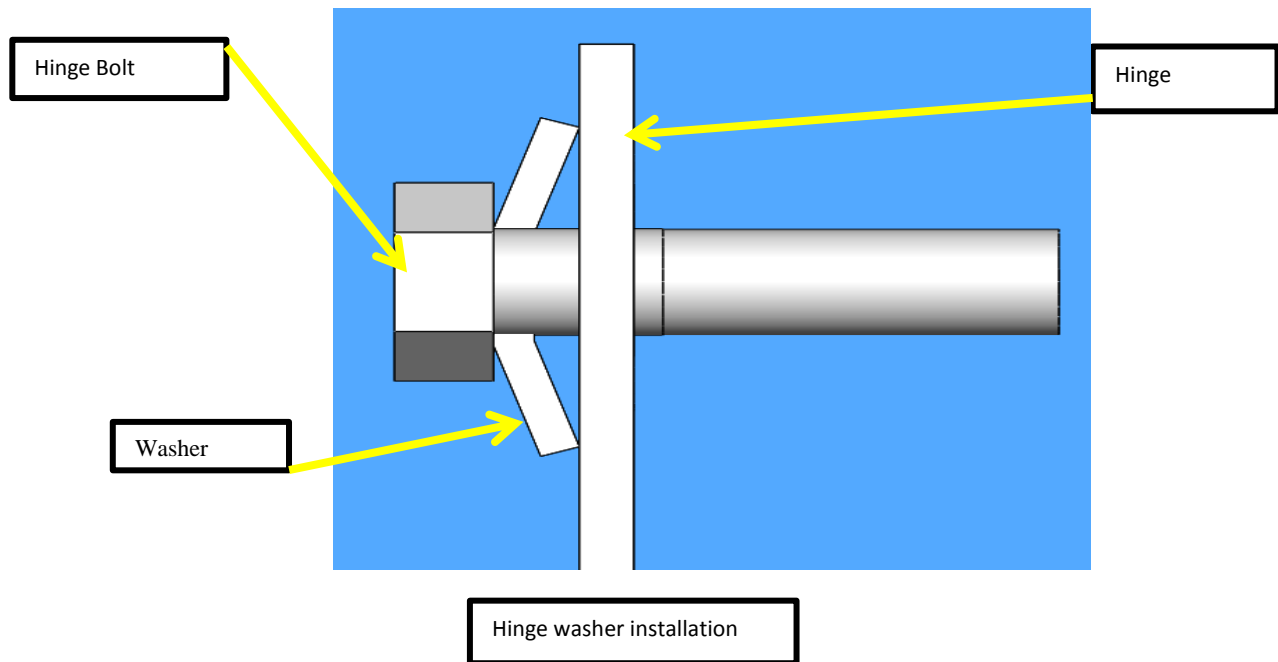

FIG.12-2

Service Bulletins are intended for use by Professional Technicians only. They are written to guide Professional Technicians in performing service to vehicles of specific nature in conjunction with industry standards. Professional Technicians should be appropriately trained on industry standards and have the tools and equipment to perform procedures safely and properly.

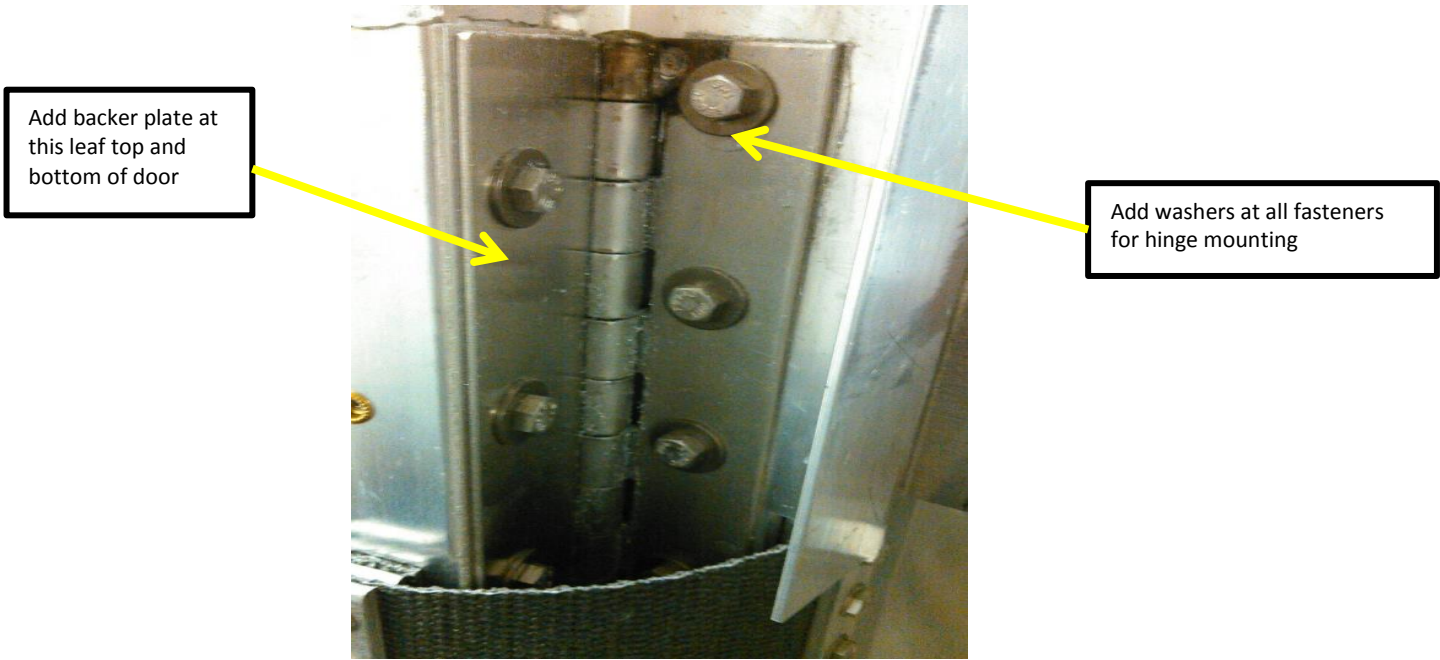

FIG. 13-1

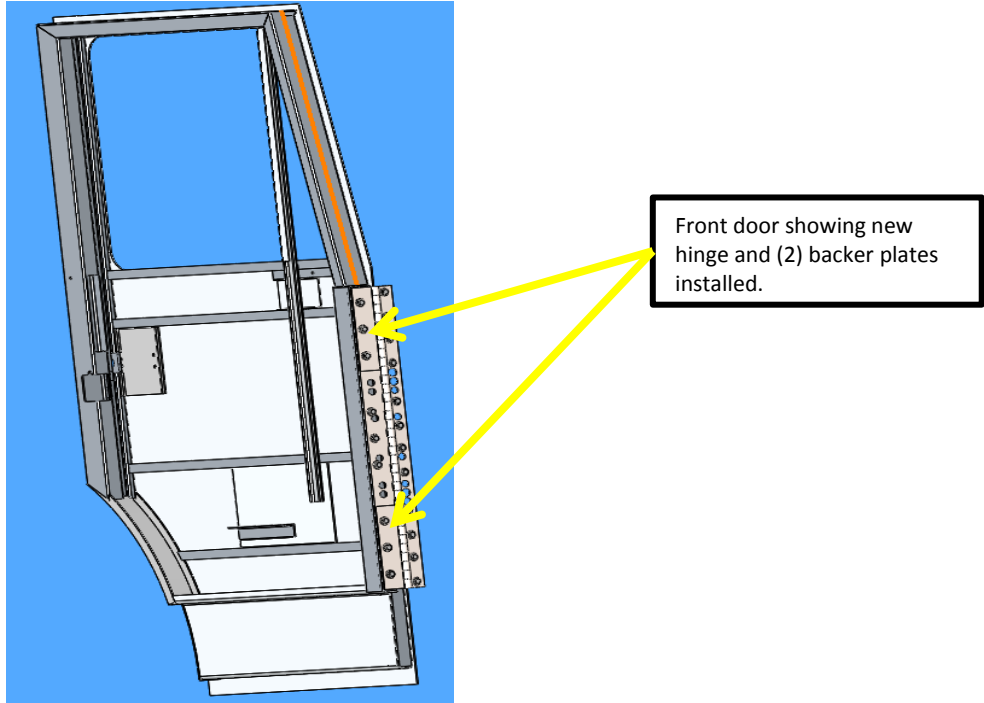

FIG.13-2

Service Bulletins are intended for use by Professional Technicians only. They are written to guide Professional Technicians in performing service to vehicles of specific nature in conjunction with industry standards. Professional Technicians should be appropriately trained on industry standards and have the tools and equipment to perform procedures safely and properly.



13. Once the hinge is properly aligned the hinge mounting fasteners **must** be torqued to 11-13 lbf-ft. Refer to FIG. 14-1.



Door alignment should be .25" to .31" gap around perimeter. Paint break line or pinstripe lined up and outside of door skin flush with sides of cab and front skin

FIG.14-1

14. Once hinge is changed and door is aligned any electrical items in the door that were removed can be re-connected and secured. Reinstall retained wire pass through spring (s) and secure them.
15. Reinstall retained door panels. During door panel re-installation, window regulator and door latch rods **must** be re-connected. Ensure rod clips are clipped onto rods securely. Refer to FIG. 15-1.

Service Bulletins are intended for use by Professional Technicians only. They are written to guide Professional Technicians in performing service to vehicles of specific nature in conjunction with industry standards. Professional Technicians should be appropriately trained on industry standards and have the tools and equipment to perform procedures safely and properly.

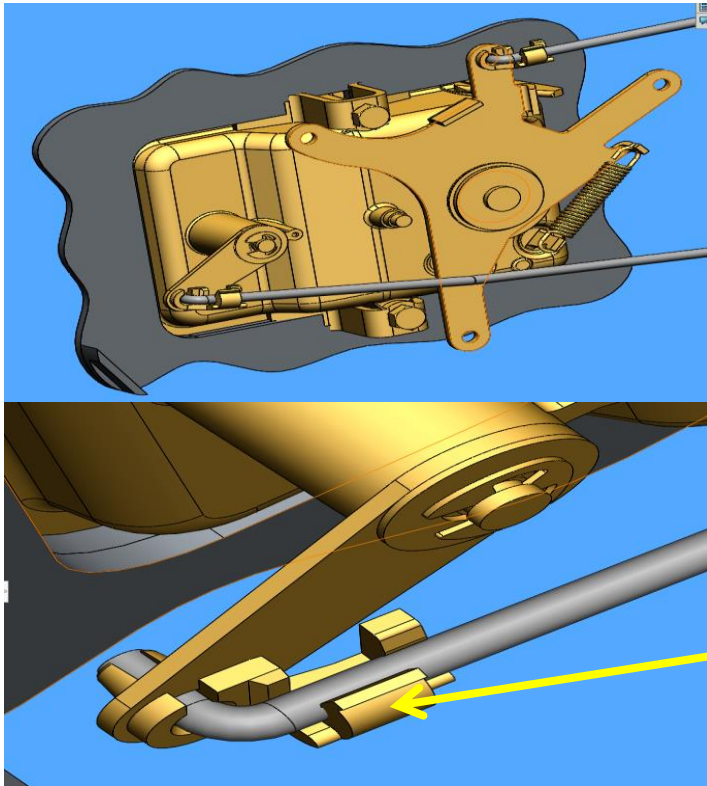

View of back of paddle handle showing rod connections

Rod installed through clip snapped onto rod securely

FIG.15-1

16. For power window regulator alignment Refer to FIG 15-2.

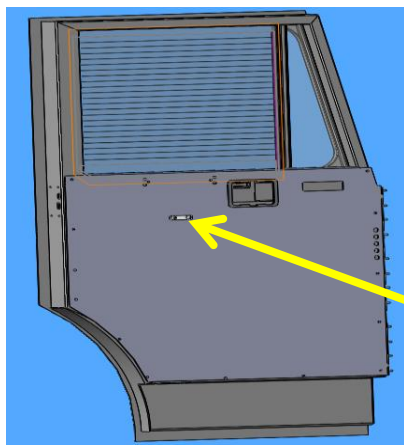

Power window configuration shown

Install these two fasteners loosely initially during re-installation. For final adjustment window needs to be rolled down approx. . . . 6" then two fasteners to be fully driven, seated and not stripped. This will allow the regulator to go up and down smoothly.

FIG.15-2

Service Bulletins are intended for use by Professional Technicians only. They are written to guide Professional Technicians in performing service to vehicles of specific nature in conjunction with industry standards. Professional Technicians should be appropriately trained on industry standards and have the tools and equipment to perform procedures safely and properly.



17. New door seals will need to be applied to new door hinges. Refer to FIG. 16-1, FIG.16-2, FIG. 17-1, FIG. 17-2 and FIG. 18-1.

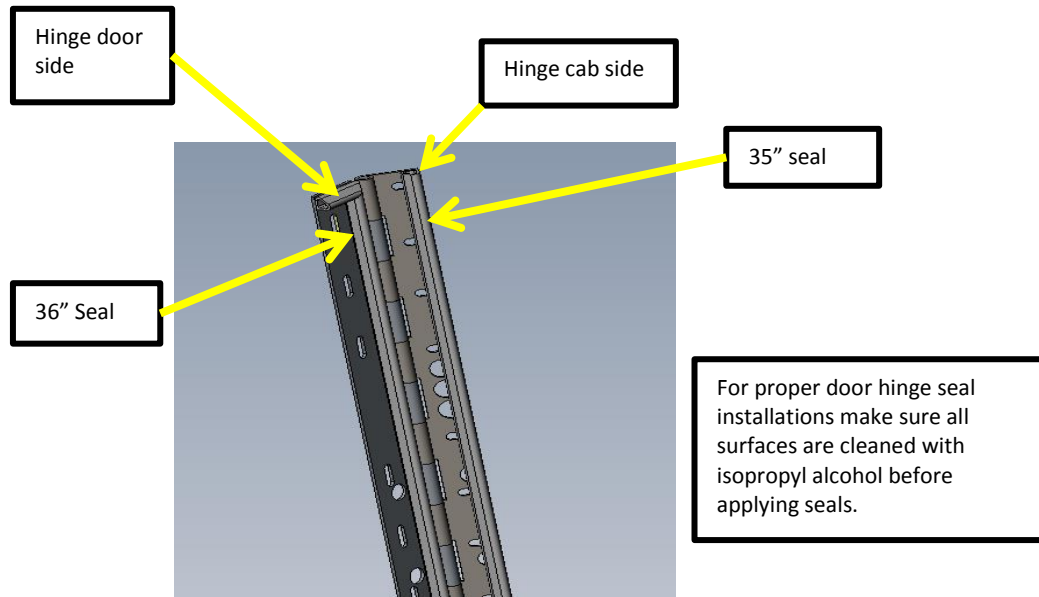

FIG.16-1



Front door seals

FIG.16-2

Service Bulletins are intended for use by Professional Technicians only. They are written to guide Professional Technicians in performing service to vehicles of specific nature in conjunction with industry standards. Professional Technicians should be appropriately trained on industry standards and have the tools and equipment to perform procedures safely and properly.

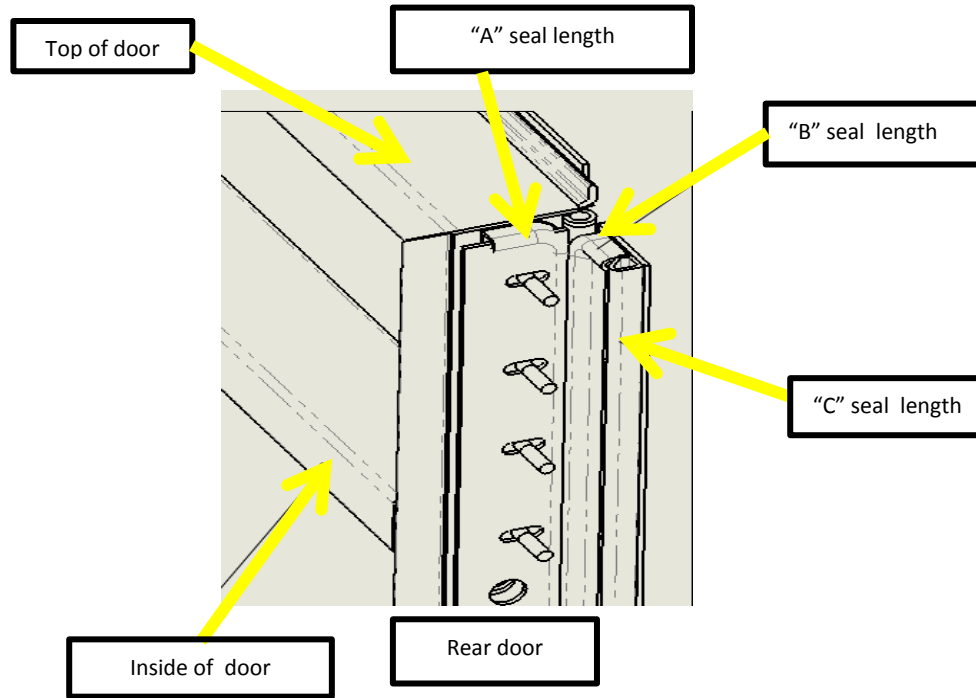

FIG.17-1

Cab roof type	"A"	"B"	"C"
Flat roof cab	51"	53"	51"
10" raised roof cab	61"	63"	61"
20" raised roof cab	71"	73"	71"

FIG.17-2

Service Bulletins are intended for use by Professional Technicians only. They are written to guide Professional Technicians in performing service to vehicles of specific nature in conjunction with industry standards. Professional Technicians should be appropriately trained on industry standards and have the tools and equipment to perform procedures safely and properly.

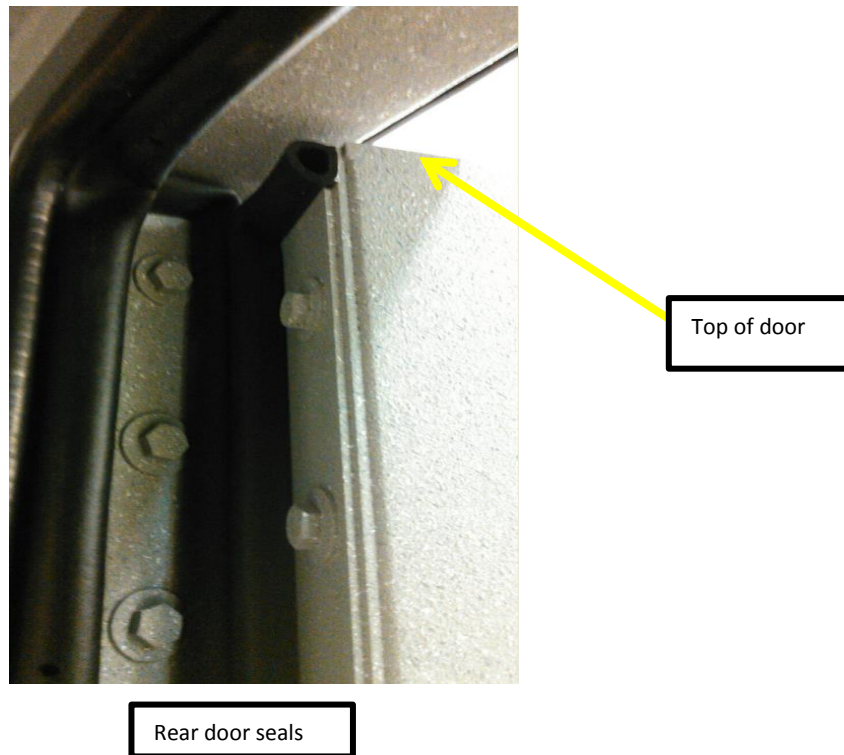

FIG.18-1

18. Once door panel is re-installed and all fasteners are tightened the door check strap can be re-installed. Door check strap fasteners to be torqued to 80-90 lbf-in.
19. At this time final adjustments to door latch striker can be made per striker/latch process 0253-ZZ4.

Service Bulletins are intended for use by Professional Technicians only. They are written to guide Professional Technicians in performing service to vehicles of specific nature in conjunction with industry standards. Professional Technicians should be appropriately trained on industry standards and have the tools and equipment to perform procedures safely and properly.