

REVISION [État]: THIS WARRANTY BULLETIN SUPERSEDES PREVIOUS VERSION.
First release

MCM SERVICE SWITCH FUNCTIONALITY- CORRECTIVE MEASURE ON I-START EQUIPPED VEHICLES 9700 (B13R)

MODEL YEAR(S) AND VEHICLE SERIAL NUMBERS (VIN) INVOLVED

NOTICE TO SERVICE CENTERS		
Verify vehicle eligibility by checking warranty bulletin status with SAP or via ONLINE WARRANTY SYSTEM available on Service / Warranty tab of Prevest website.		
Model	VIN	
Volvo 9700 us/can with I-Start system MODEL YEAR: 2016	3CET2V222G5174801	3CET2V224G5178414
	3CET2V220G5177311	3CET2V226G5178415
	3CET2V222G5177312	3CET2V228G5178416
	3CET2V224G5177313	3CET2V225G5178535
	3CET2V226G5177314	3CET2V227G5178536
	3CET2V223G5178405	3CET2V229G5178537
	3CET2V225G5178406	3CET2V220G5178538
	3CET2V227G5178407	3CET2V222G5178539
	3CET2V229G5178408	3CET2V229G5178540
	3CET2V220G5178409	3CET2V220G5178541
	3CET2V227G5178410	3CET2V224G5178543
	3CET2V229G5178411	3CET2V226G5178544
	3CET2V220G5178412	3CET2V228G5178545
	3CET2V222G5178413	3CET2V22XG5178546
This bulletin does not necessarily apply to all the above-mentioned vehicles, some vehicles may have been modified before delivery. The owners of the vehicles affected by this bulletin will be advised by a letter indicating the Vehicle Identification Number (VIN) of each vehicle concerned.		





DESCRIPTION

On the vehicles affected by this bulletin, a fix is required to allow normal functionality of the MCM switch.

This switch is used when the MCM is being programmed.

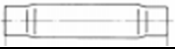
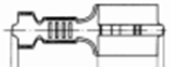
MATERIAL

Order kit **WB17-81** which contains the following part::

Part No.	Description		Qty
956956	SPLICE		3
970590	ELECTRIC CABLE (ORANGE) Insulated single-core cables type R2 0.5 mm ² 2.5 m long		98 in
970592	ELECTRIC CABLE (GREEN) 2.5 m long		98 in
970595	ELECTRIC CABLE (GREY) 2.5 m long		98 in
970745	CABLE TERMINAL 0.8 6.3 0.5-1		2
20734499	SEAL, CABLE TERMINAL		3
980464	NYLON CABLE TIE		7
25371156	CONNECTOR HOUSING, BMUX BODY SIDE		1
984945	CABLE TERMINAL		3

NOTE

Material can be obtained through regular channels.

Date	Expiration	Group	No.	Page
10.2017	10.2017			3(9)

PROCEDURE



DANGER

Park vehicle safely, apply parking brake, stop engine. In the battery box, set the battery cut-off switch to the OFF position prior to working on the vehicle.

- 1) Turn off the main switch on the dashboard.
- 2) Turn off the power supply.
- 3) In the entrance step well, open service hatch and unplug S9077 connector.



- 4) Disconnect the **purple wire** at cavity **A1**
- 5) Disconnect the **gray wire** at cavity **A2** and cut off end terminal. Double crimp **gray wire** with the **purple wire from A10** using terminal #970745 and then connect to cavity **A2**.
- 6) Cut the **white wire** routed between A9 and MCM module (A36) at about 6 inches from S9077.
- 7) Seal off the white wire end routed to MCM (A36) or remove this wire completely.
- 8) Disconnect the **white wire** at cavity **A7** and cut off end terminal. Double crimp the **white wire** with the **white wire from A9** using terminal #970745 and then connect to cavity **A7**.

Note: Repair standard process according to: Impact Identity 137677231 (371 Cable repair), repair should require cable terminal #970745.

Before

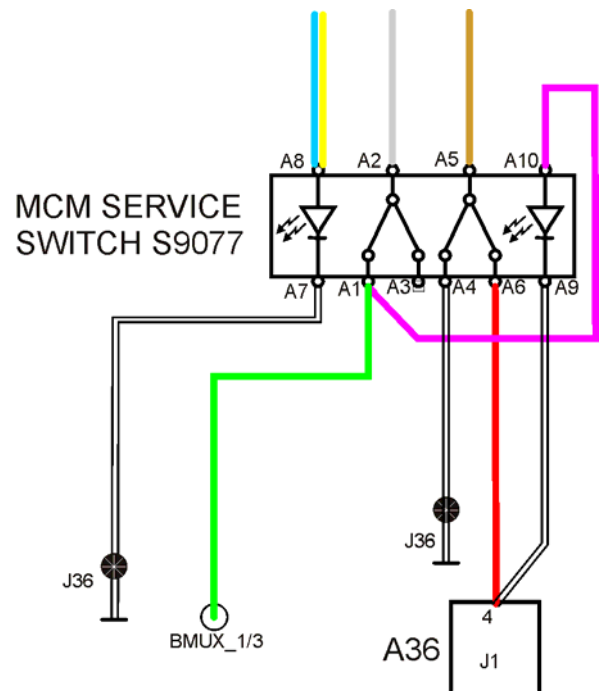

After

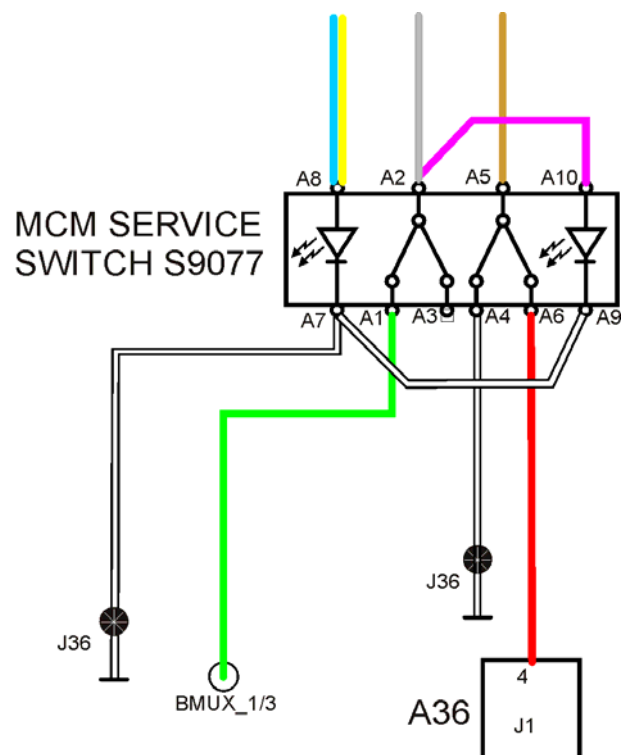

- 9) Locate the following wires and PVC pipe:
BMUX_1/1 (Grey),
BMUX_1/2 (Orange),
BMUX_1/3 (Green) wires.

NOTE: (orange & grey wires are twisted together)

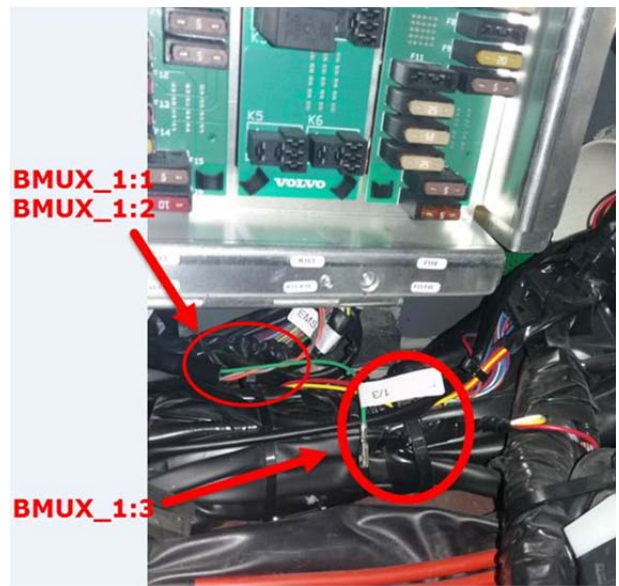
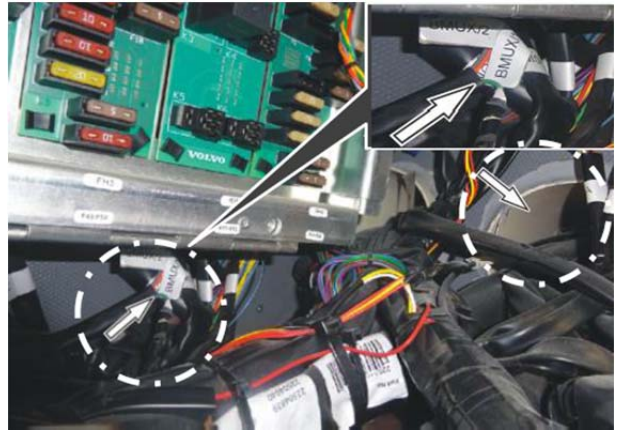

- 10) Disconnect BMUX/1 and BMUX/2 (orange & grey wires twisted together) wires from EMS connector.

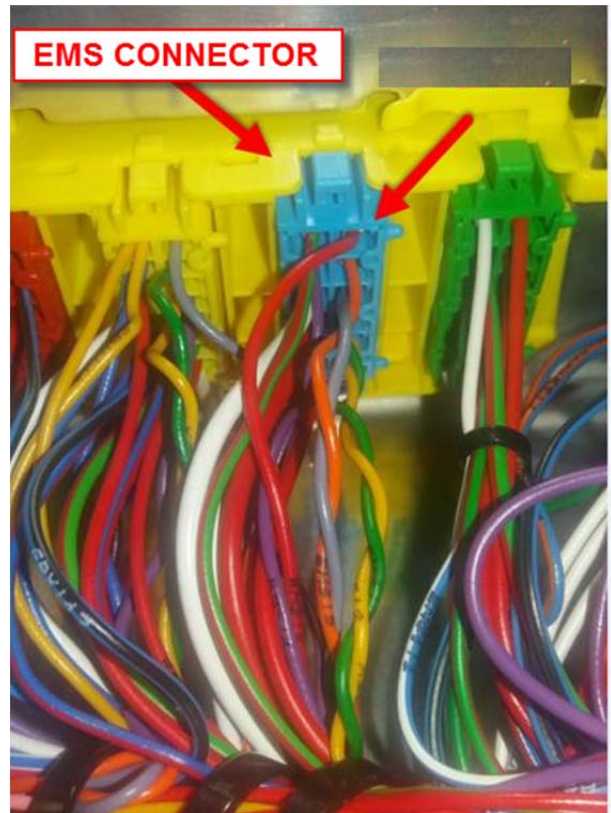

- 11) Extend BMUX/1, BMUX/2, BMUX_1/3 using splice #956956 and corresponding color coded wire. IMPORTANT: Read the note below.

Note: BMUX/1 & BMUX/2 (orange & grey wires) must be twisted together: twist pitch 9.2 turns/ft (30 turns/meter), that makes 75 turns for 98" long wire.

Note: Use nylon ties along the routing line as required.

Date	Expiration	Group	No.	Page
10.2017	10.2017			7(9)

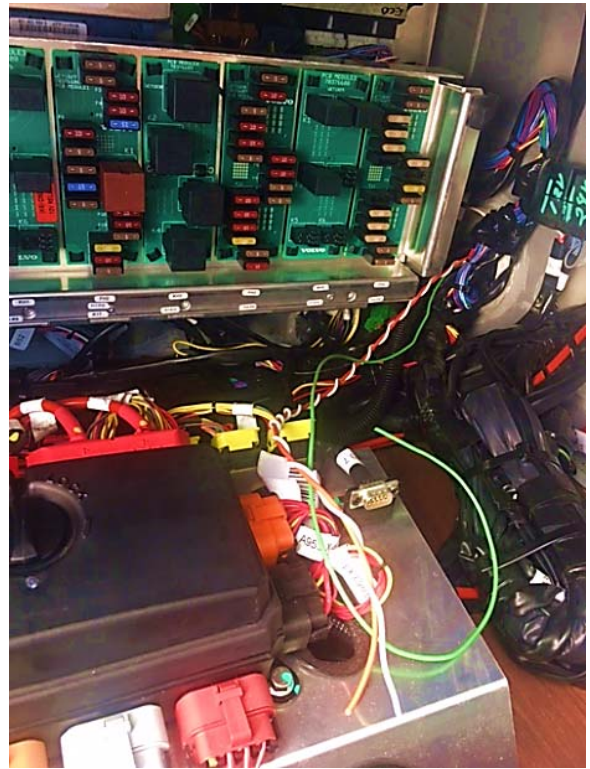

- 12) Open the service hatch behind driver seat.
- 13) Install BMUX connector (**#25371156**). Route wires in PVC pipe in order to reach BMUX connector.

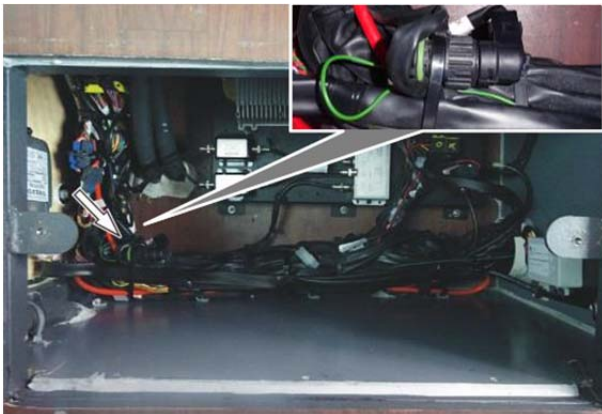

Date	Expiration	Group	No.	Page
10.2017	10.2017			8(9)

14) Connect wires to BMUX connector as follows:

- BMUX/1 to cavity 1,
- BMUX/2 to cavity 2,
- BMUX_1/3 to cavity 3.

Note: Use terminals #984945 and seal #20734499 for each wire to secure the pin contact.

Note: Refer to Impact Identity 137677231 (371 Cable repair)

CHECK

15) Perform a functionality test:

This symbol must pop up when the switch is activated and it should not be possible to crank the engine.



16) Turn on the power supply.

17) Turn on the main switch.

PARTS / WASTE DISPOSAL

DO NOT RETURN THE REPLACED PARTS. Discard waste according to applicable environmental regulations (Municipal/State[Prov.]/ Federal)

WARRANTY

This modification is covered by Prevost's normal warranty. We will reimburse you the parts and one hour and a half (1.5) of labor upon receipt of a warranty claim. Please submit claim via our Online Warranty System, available at www.prevostcar.com (under Service \ Warranty section). Use Claim Type: "Bulletin/Recall" and select "Warranty Bulletin WB17-81".

OTHER

VBC Bulletin	S0365
Fail Code	06.00
Defect Code	09
Syst. Cond	B
Causal Part	984944

Access all our Service Bulletins on
<http://techpub.prevostcar.com/en/>

or scan the QR-Code with your smart phone.

E-mail us at technicalpublications_prev@volvo.com and type "ADD"
in the subject to receive our warranty bulletins by e-mail.



Prevost engages in a continuous program of testing and evaluating to provide the best possible product. Volvo Bus, however, is not committed to, or liable for updating existing products.