

JTB00571NAS1

TECHNICAL BULLETIN

05 OCT 2017



© Jaguar Land Rover North America, LLC

NOTE: The information in Technical Bulletins is intended for use by trained, professional Technicians with the knowledge, tools, and equipment required to do the job properly and safely. It informs these Technicians of conditions that may occur on some vehicles, or provides information that could assist in proper vehicle service. The procedures should not be performed by 'do-it-yourselfers'. If you are not a Retailer, do not assume that a condition described affects your vehicle. Contact an authorized Jaguar service facility to determine whether this bulletin applies to a specific vehicle.

INFORMATION**SECTION:**

501-3: Body Closures

SUBJECT/CONCERN:

Creak Noise From A-Pillar and/or B-Pillar When Opening Front or Rear Door

AFFECTED VEHICLE RANGE:

MODEL:	MODEL YEAR:	VIN:	ASSEMBLY PLANT:
XF (X260)	2016-2017	Y00001-Y42588	Castle Bromwich

MARKETS:NORTH AMERICA

CONDITION SUMMARY:**SITUATION:**

A creak noise may be evident from the A-Pillar and/or B-Pillar area when opening a front or rear door.

CAUSE:

This may be caused by E-coat contamination between A-Pillar and/or B-Pillar outer body panel and the inner structure creating a rough surface and causing the noise when the panel flexes during door opening.

ACTION:

Should a customer express this concern, follow the appropriate Rework Procedure(s) below.

PARTS:**NOTE:**

* - an allowance (\$2.50 USD [or local equivalent]) has been provided to cover the cost of the locally sourced PTFE dry lubricant spray. Claim using Sundry Code 'ZZZ001'.

PART NUMBER	DESCRIPTION	QUANTITY:
*ZZZ001	*PTFE dry lubricant spray	1
T2H4668	Door check arm assembly - Front door	1
T2H4669	Door check arm assembly - Rear door	1

TOOLS:

Refer to Workshop Manual for any required special tools.

WARRANTY:**NOTES:**

- Repair procedures are under constant review, and therefore times are subject to change; those quoted here must be taken as guidance only. Always refer to TOPIx to obtain the latest repair time.
- The JLR Claims Submission System requires the use of causal part numbers. Labor only claims must show the causal part number with a quantity of zero

DESCRIPTION	SRO	TIME (HOURS)	CONDITION CODE	CAUSAL PART
A-Pillar creak - Door check arm renew and clean hinge mountings - Rework procedure 1 (single side)	76.11.68	1.00	D4	T2H3038
A-Pillar creak - Door check arm renew and clean hinge mountings - Rework procedure 1 (both sides)	76.11.68.99	2.0	D4	T2H3038
B-Pillar creak - Door check arm renew and clean hinge mountings - Rework procedure 2 (single side)	76.11.89.01	1.00	D4	T2H3038
B-Pillar creak - Door check arm renew and clean hinge mountings - Rework procedure 2 (both sides)	76.11.89.02	2.00	D4	T2H3038
B-Pillar creak - Drill, plug weld, and paint - Modification - Rework procedure 3 (single side)	76.11.69	1.2	D4	T2H3038
B-Pillar creak - Drill, plug weld, and paint - Modification - Rework procedure 3 (both sides)	76.11.69.99	1.8	D4	T2H3038

NOTE:

Normal Warranty procedures apply.

REWORK PROCEDURE 1: FRONT DOOR A-PILLAR

NOTE:

Left-side shown; right-side similar.

- 1 Open the affected front door as per the customer concern.

2 



E212044

Open the door onto the hinge stops and apply pressure against the door check arm until a creak/click is heard.

- Repeat this process until the creak/click can no longer be heard.

- 3 Remove the front door bass speaker (see TOPIx Workshop Manual section 415-01: Information and Entertainment System).

- 4 Remove the front door which is the cause of the customer concern (see TOPIx Workshop Manual section 501-03: Body Closures).

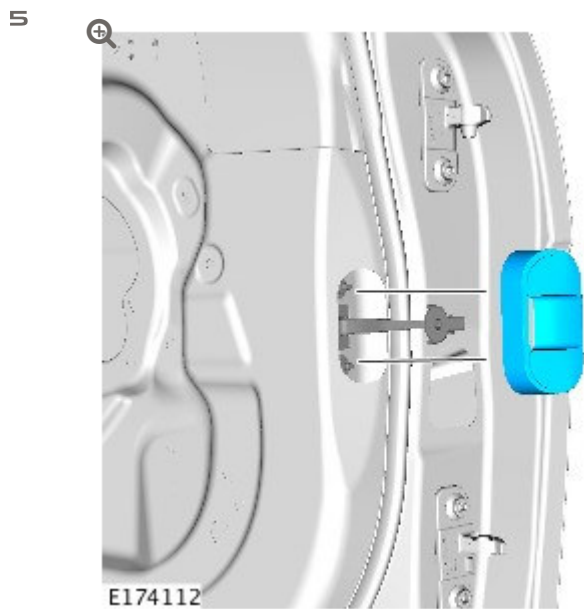

Remove the foam pad.

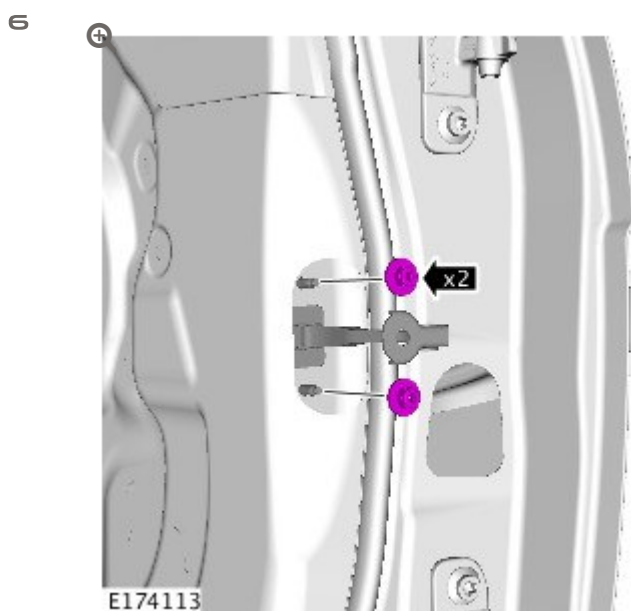

Remove the 2 nuts from the door check arm.

7

NOTE:

Retain the door check arm assembly until Step 17 has been completed.

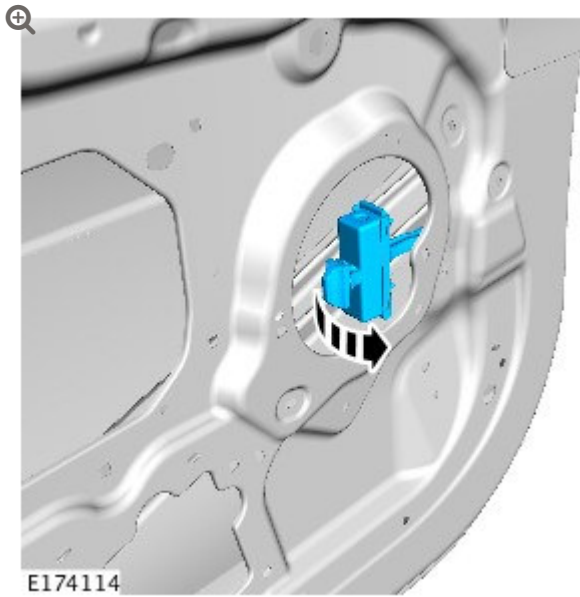

Remove and retain the door check arm assembly.

8

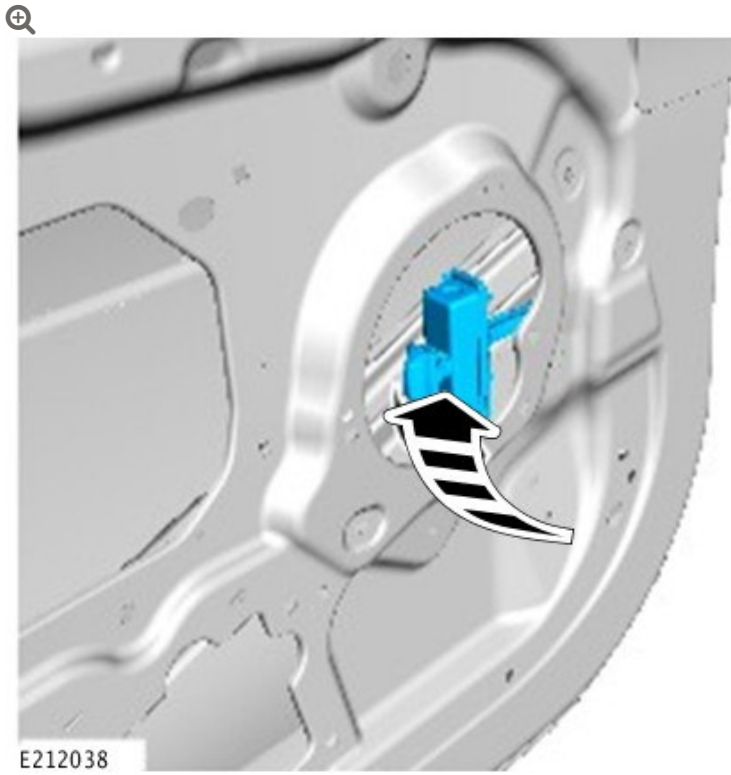

Install a new door check arm assembly.

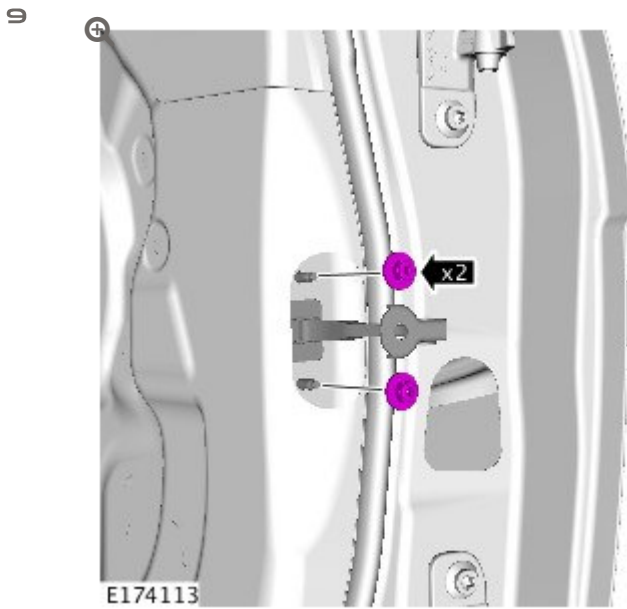

Install the 2 door check arm nuts.

- Torque: **10 Nm.**

10

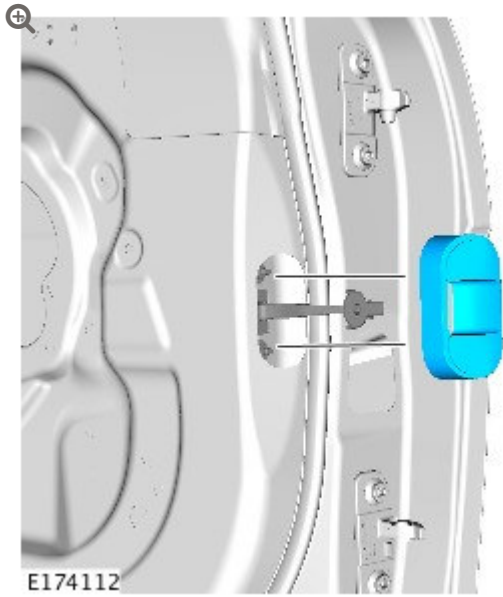

Install the foam pad.

11

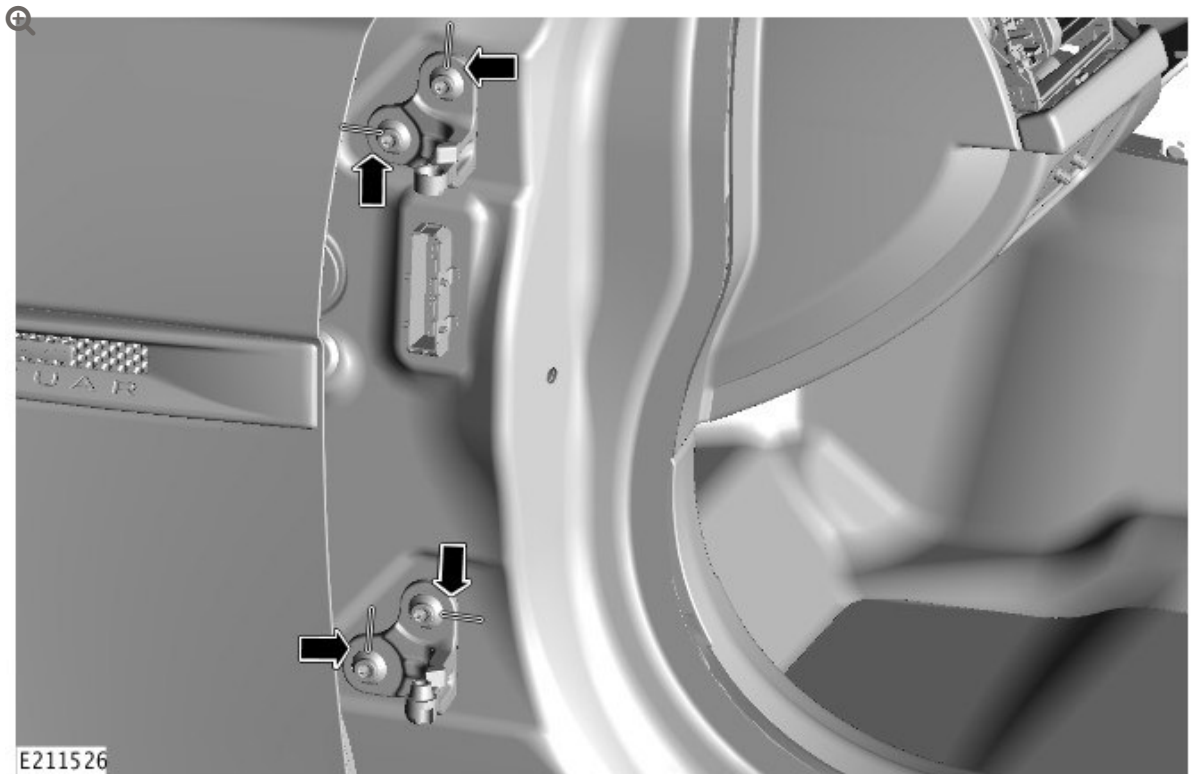

Use a non-permanent pen to mark the hinge positions against the A-Pillar as illustrated.

12

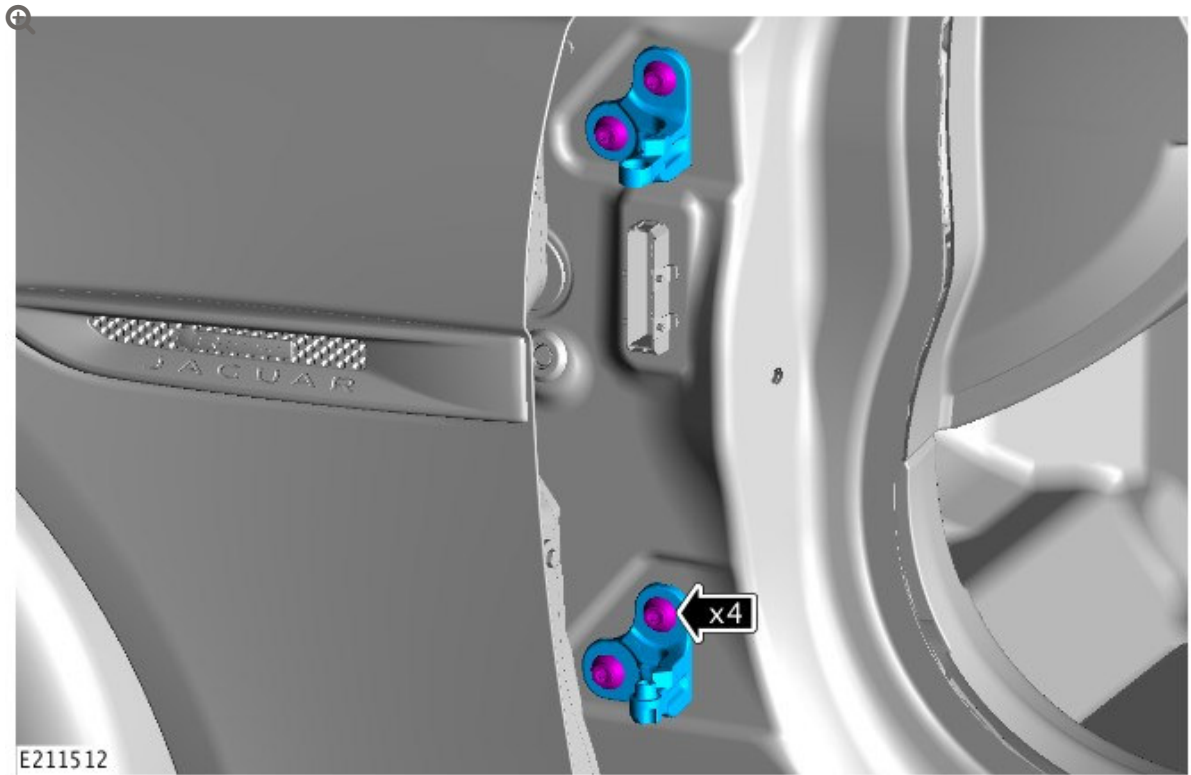

Remove the front door hinges from the vehicle.

13

CAUTION:

Make sure not to damage the surrounding paintwork.

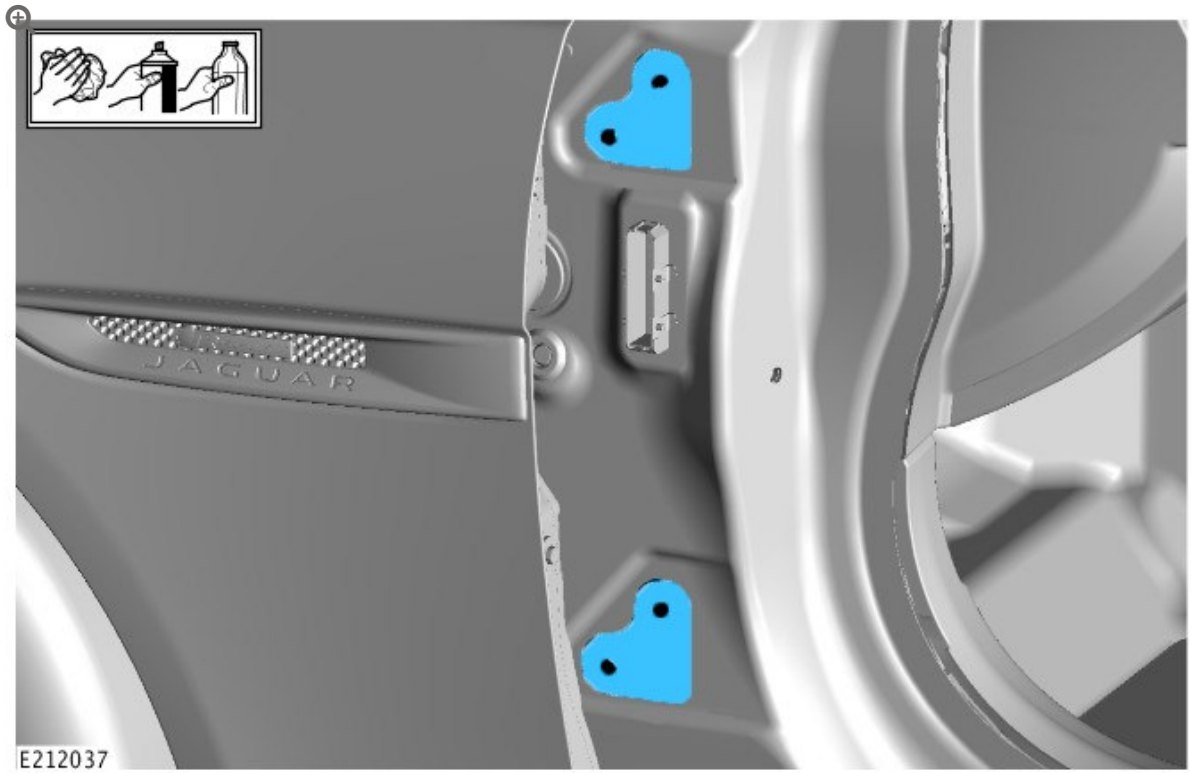

Remove the e-coat layer from the hinge mounting surfaces on the A-Pillar.

14

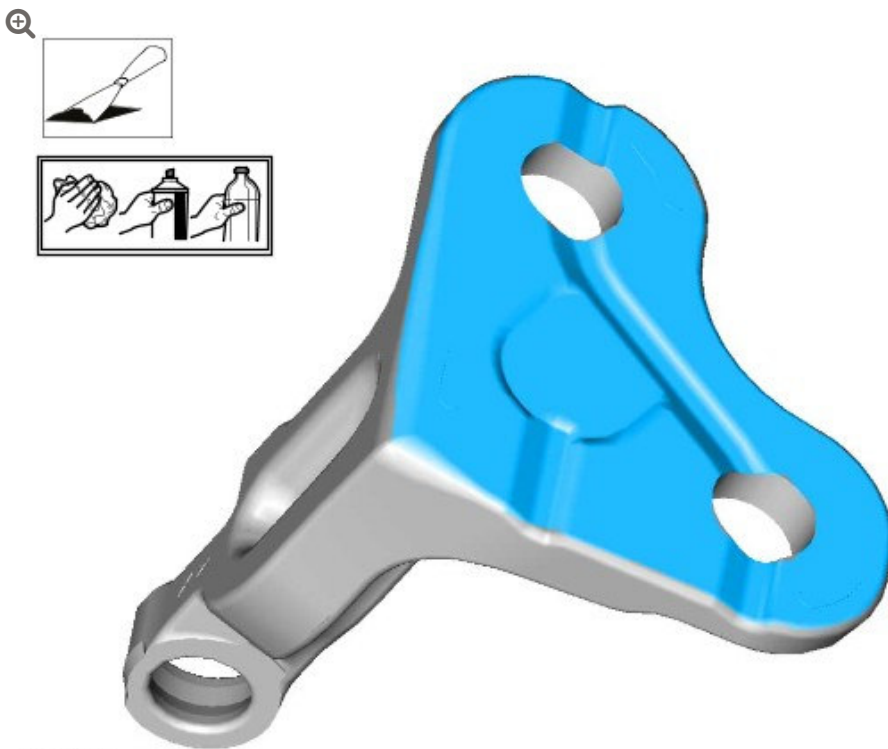

Use a suitable tool to remove the e-coat layer from the mounting surfaces of the front door hinges.

- Clean the area with a suitable cleaner after the e-coat layer has been removed.

15

NOTE:

Make sure to open a gap between the outer and inner B-Pillar body panels around the full circumference of each hole shown in the illustration.

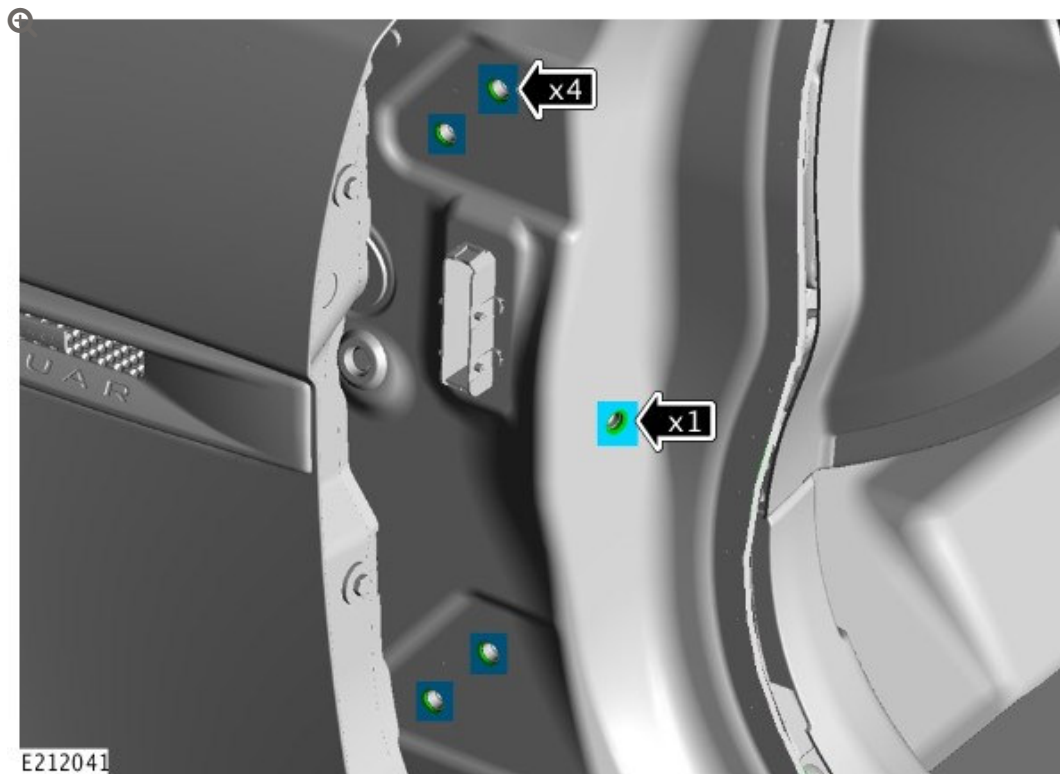

In the 5 positions highlighted, use a suitable tool to open a small gap between the A-Pillar outer body panel and the A-Pillar inner body panel.

16

NOTE:

Make sure to apply PTFE dry lubricant to the gap around the full circumference of each hole.

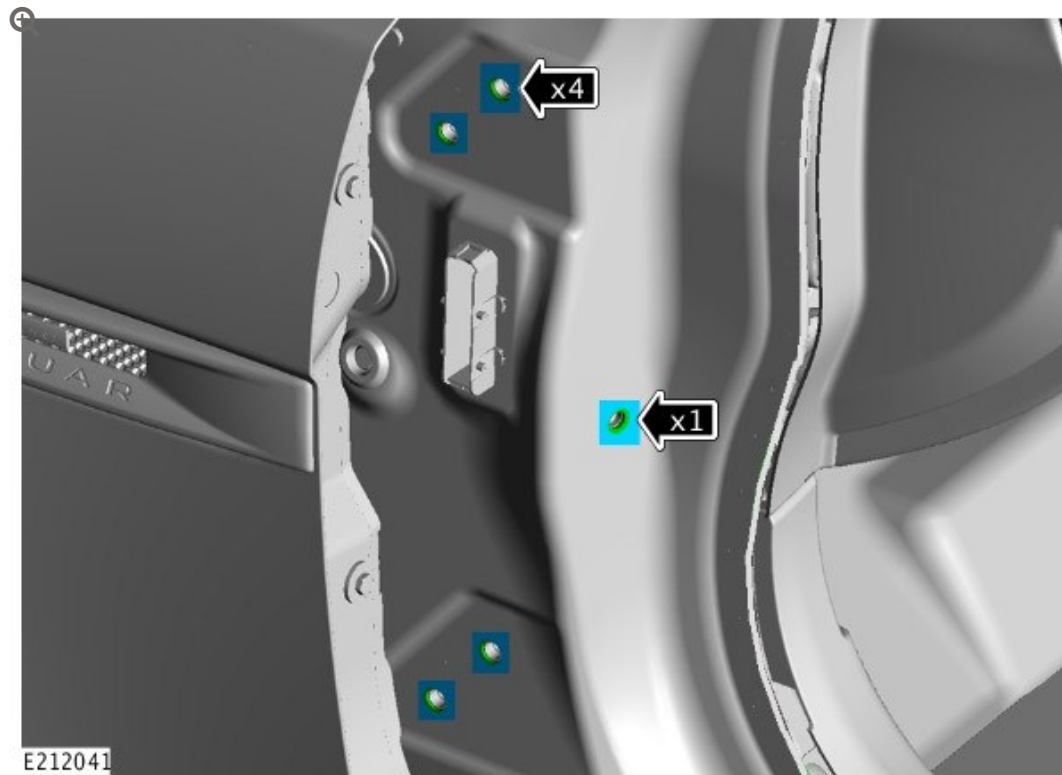

In the 5 positions highlighted, apply the PTFE dry lubricant into the gap between the A-Pillar outer body panel and A-Pillar inner body panel.

- Make sure to spray the PTFE dry lubricant between the body panels for approximately 15 seconds for each area highlighted.

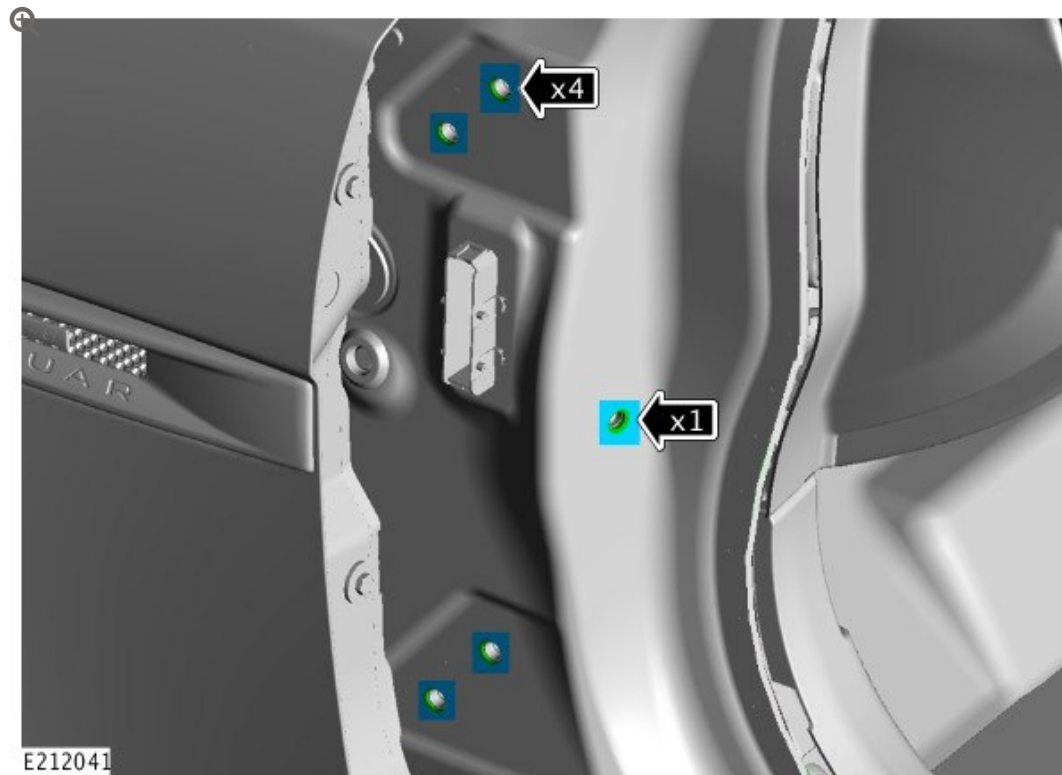

Close the gap between the A-Pillar body panels.

- Install the 4 hinge fasteners and tighten (Torque: **35 Nm**) to close the gap between the A-Pillar body panels.
 - Remove the 4 fasteners.
- Install the original door check arm with fixing and tighten (Torque: **24 Nm**) to close the gap between the A-Pillar body panels.
 - Remove the fastener and discard the original door check arm assembly

18

NOTE:

Make sure to install the hinges in the previously marked positions.

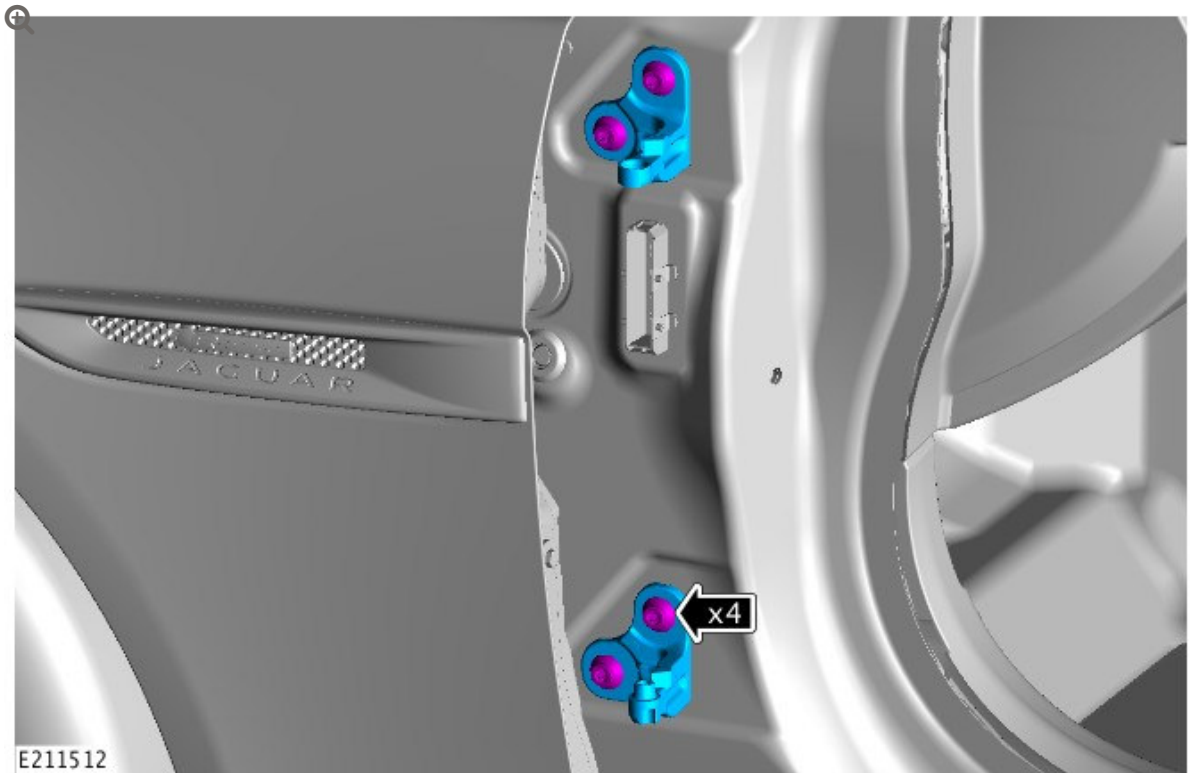

Install the front door hinges.

- Torque: **35 Nm**.
- Remove any evidence of the hinge position markings.

19

NOTE:

Make sure to apply grease to the door hinges and door check arm on installation.

Install the front door (see TOPIx Workshop Manual section 501-03: Body Closures).

20 Install the front door bass speaker (see TOPIx Workshop Manual section 415-01: Information and Entertainment System).

21 Check the alignment of the front door (see TOPIx Workshop Manual section 501-26: Body Repairs - Vehicle Specific Information And Tolerance Checks).

22 **Only if required:** repeat steps 1-21 on the opposite side of the vehicle.

¹ If not required, go to Step 23.

23 Confirm that the rework procedure has successfully resolved the customer concern.

- If the rework procedure has successfully resolved the customer concern and no rear doors are affected, **do not continue with this Technical Bulletin.**
- If the rework procedure has successfully resolved the customer concern but a rear door is also affected, **continue to Rework Procedure 2 below.**
- If the rework procedure has failed to resolve the customer concern, **raise a Technical Assistance (TA) relating to this concern for further assistance.**

REWORK PROCEDURE 2: REAR DOOR B-PILLAR

NOTE:

Left-side shown; right-side similar.

¹ Open the rear door which is the cause of the customer concern.

2



E211523

Open the rear door onto the hinge stops and apply pressure against the door check arm until a crack or click is heard.

- Repeat this process until the crack/click can no longer be heard.

3 Remove the rear door bass speaker (see TOPIx Workshop Manual section 415-01: Information and Entertainment System).

4 Remove the rear door which is the cause of the customer concern (see TOPIx Workshop Manual section 501-03: Body Closures).

5

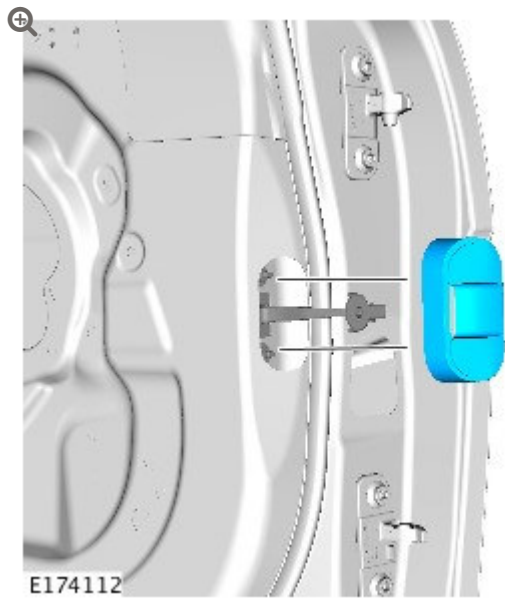

Remove the foam pad.

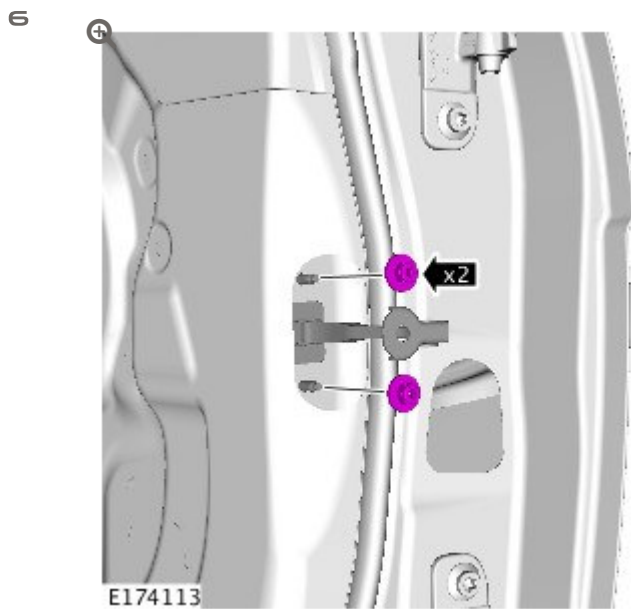

Remove the 2 nuts from the door check arm.

7

NOTE:

Retain the original door check arm assembly until Step 17 has been completed.

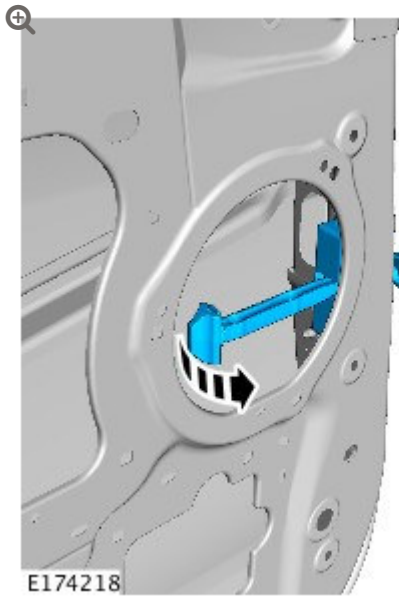

Remove the original door check arm assembly.

8



Install a replacement door check arm assembly.

9

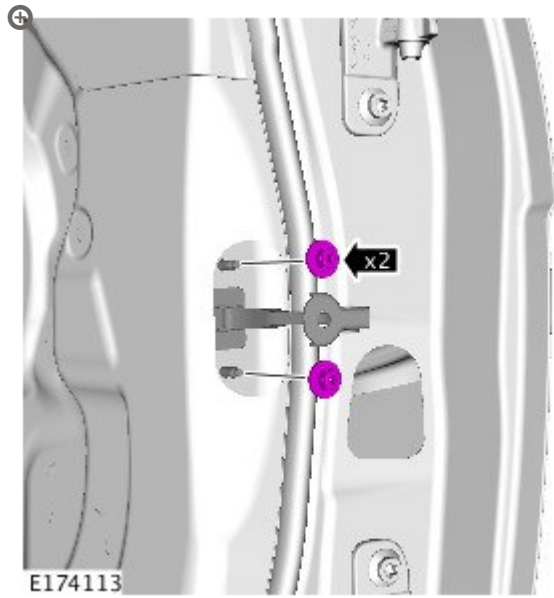

Install the 2 nuts to retain the door check arm.

- Torque: **10 Nm.**

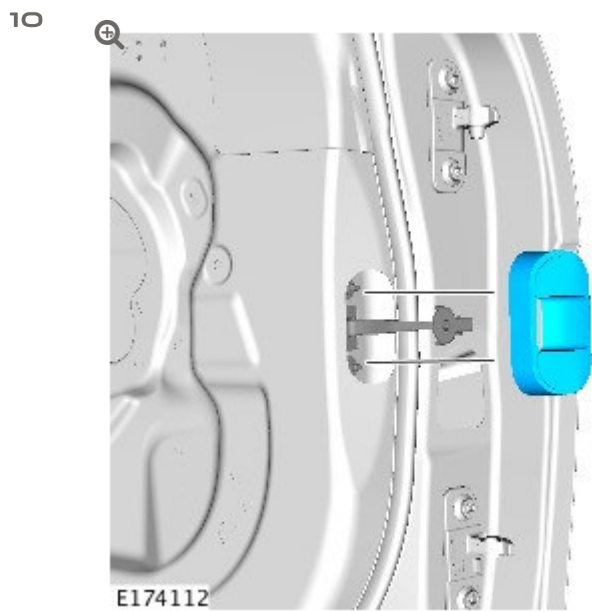

Install the foam pad.



Use a non-permanent marker to mark the hinge positions against the B-Pillar as illustrated to improve alignment for installation.



Remove the rear door hinges.

13

CAUTION:

Make sure not to damage the surrounding paintwork.

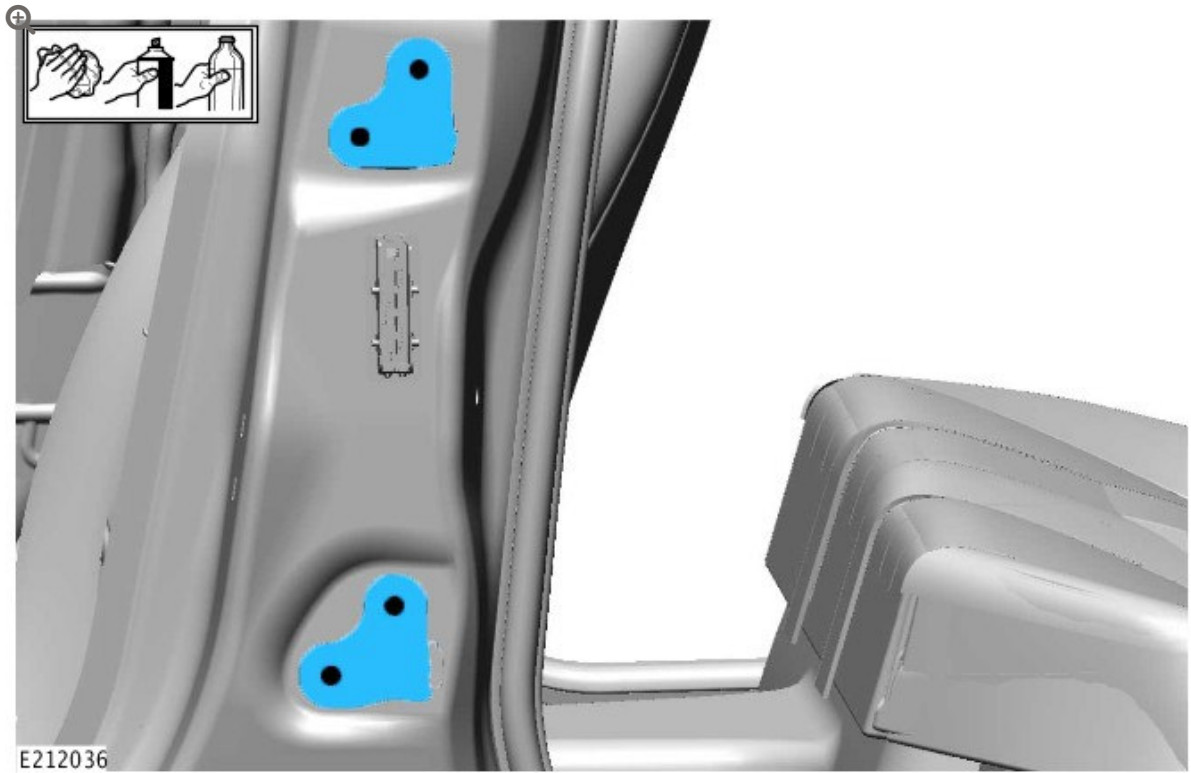

Remove the e-coat layer from the hinge mounting surfaces on the A-Pillar.

14

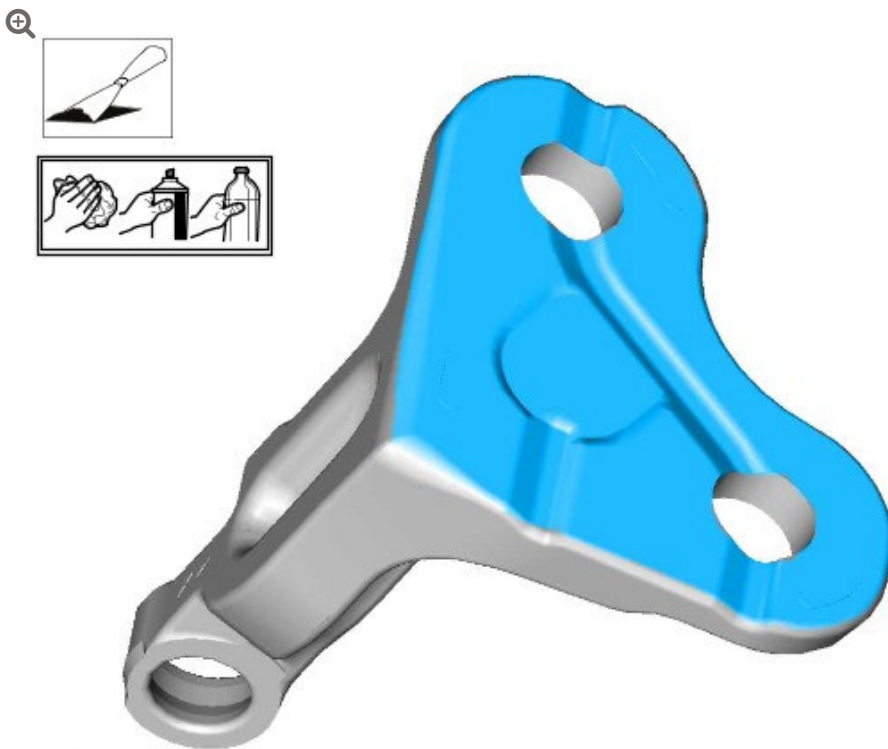

E211524

Use a suitable tool to remove the e-coat layer from the mounting surfaces of the front door hinges.

- Clean the area with a suitable cleaner after the e-coat layer has been removed.

15

NOTE:

Make sure to open a gap between the outer and inner B-Pillar body panels around the full circumference of each hole shown.

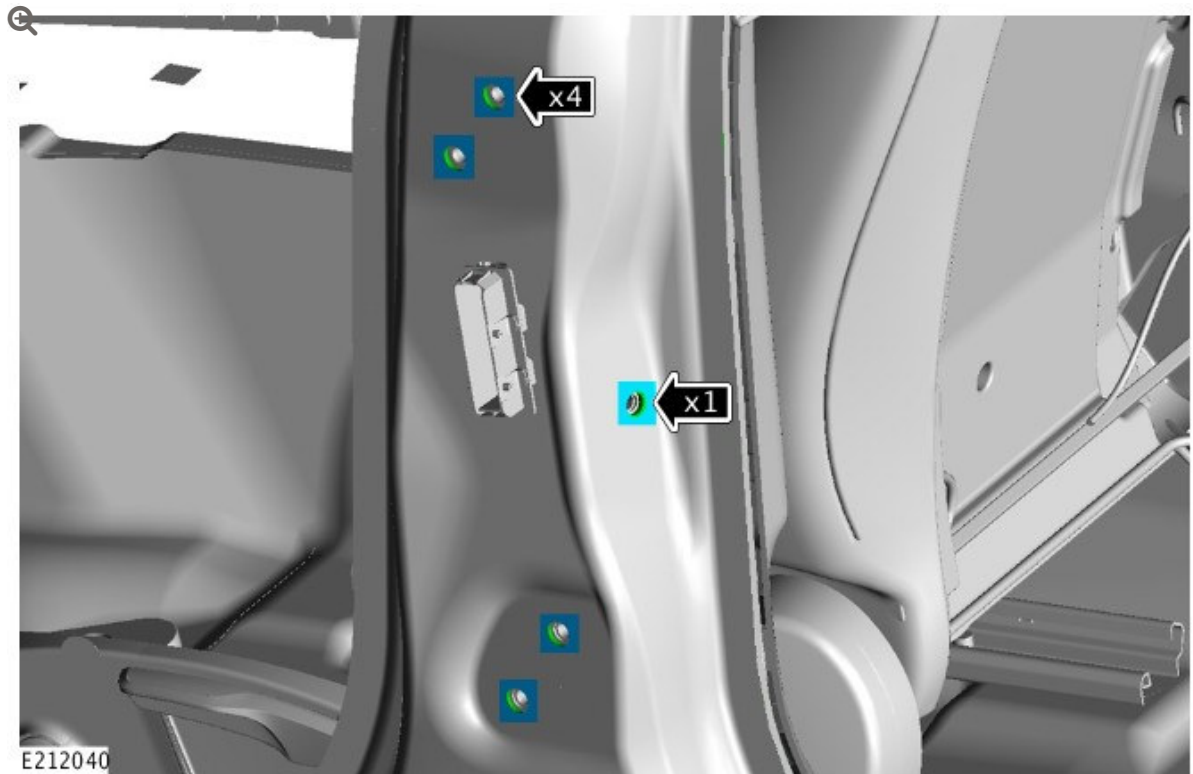

In the 5 positions highlighted, use a suitable tool to open a small gap between the B-Pillar outer body panel and the B-Pillar inner body panel.

16

NOTE:

Make sure to apply PTFE dry lubricant to the gap around the full circumference of each hole.

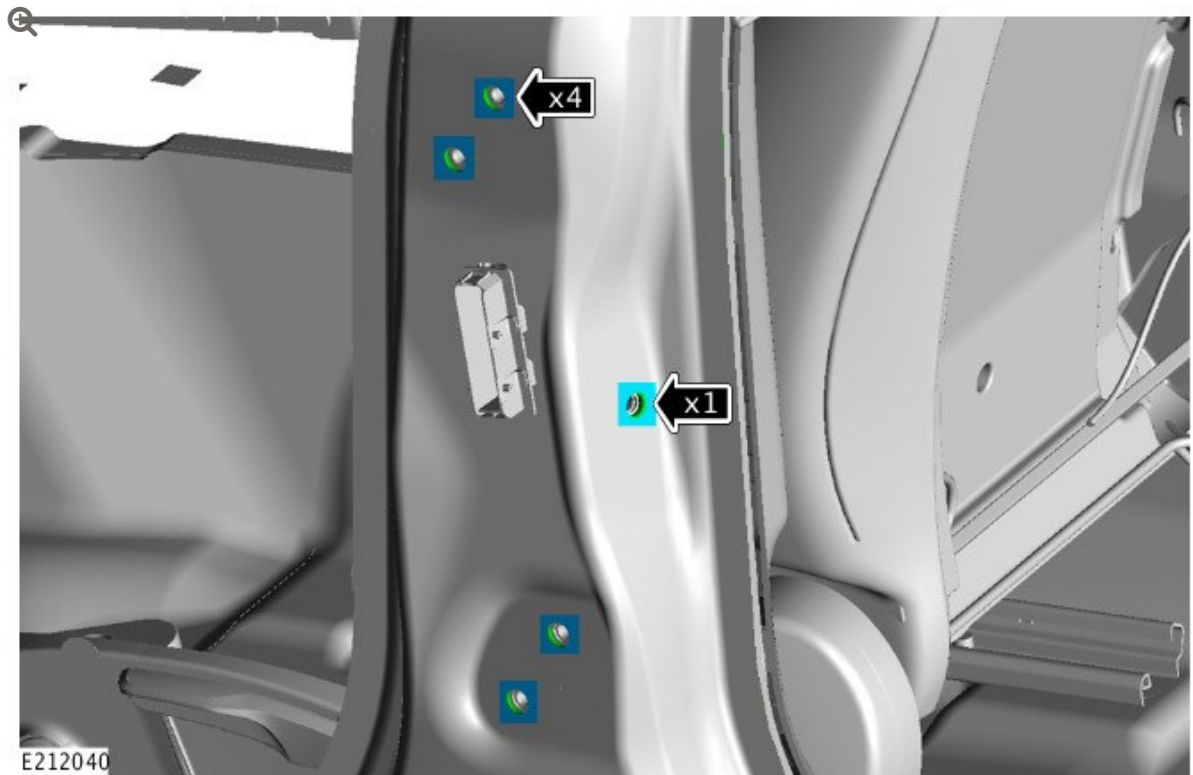

In the 5 positions highlighted, apply the PTFE dry lubricant into the gap between the B-Pillar outer body panel and B-Pillar inner body panel.

- Make sure to spray the PTFE dry lubricant between the body panels for approximately 15 seconds per area highlighted.

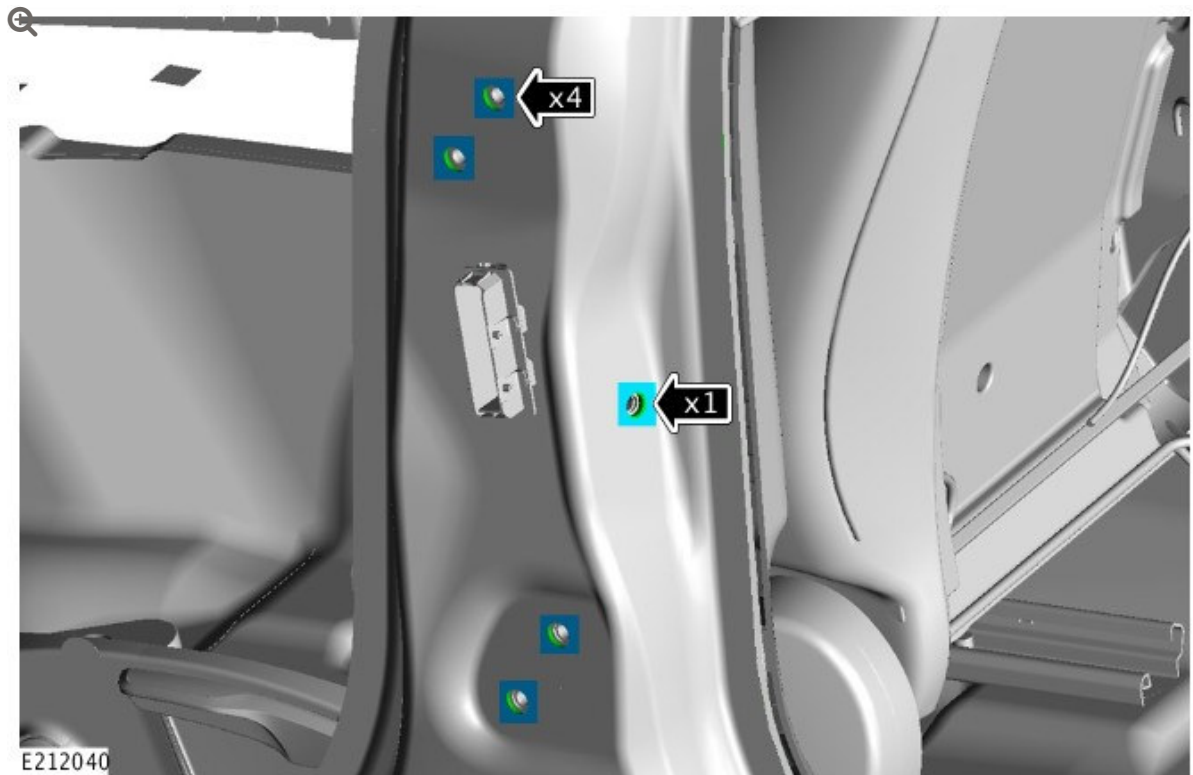

Close the gap between the B-Pillar body panels.

- Install the 4 hinge fasteners and tighten (Torque: **35 Nm**) to close the gap between the B-Pillar body panels.
 - Remove the 4 fasteners.
- Install the original door check arm with fixing and tighten (Torque: **24 Nm**) to close the gap between the B-Pillar body panels.
 - Remove the fastener and discard the original door check arm assembly.

18

NOTE:

Make sure to install the hinges in the previously marked positions.



Install the rear door hinges.

- Torque: **35 Nm**.
- Remove any evidence of the hinge position markings.

19

NOTE:

Make sure to apply grease to the door hinges and door check arm on installation.

Install the rear door (see TOPIx Workshop Manual section 501-03: Body Closures).

20 Check the alignment of the rear door (see TOPIx Workshop Manual section 501-26: Body Repairs).

21 **Only if required:** repeat steps 1-20 on the opposite side of the vehicle.

- 1 If not required, go to Step 22.
-

- 22 Confirm that the rework procedure has successfully resolved the customer concern.
- If the rework procedure has resolved the customer concern, **do not continue with this Technical Bulletin.**
 - If the rework procedure has not resolved the customer concern, **continue to Rework Procedure 3 below.**

REWORK PROCEDURE 3: B-PILLAR BODY PANEL MODIFICATION PROCEDURE

NOTES:

- Some parts are shown removed for clarity.
- Left-side shown; right-side similar.

-
- ¹ Remove the rear door which is the cause of the customer concern (see TOPIx Workshop Manual section 501-03: Body Closures - Rear Door [complete steps 6-8 only]).
-

2



Apply masking tape to the area highlighted.

3 Seal the rear door aperture to avoid any damage to the interior of the vehicle.

4

WARNING:

Make sure to wear suitable personal protective equipment.

CAUTION:

Make sure to only drill through the outer skin of the B-Pillar body panel.

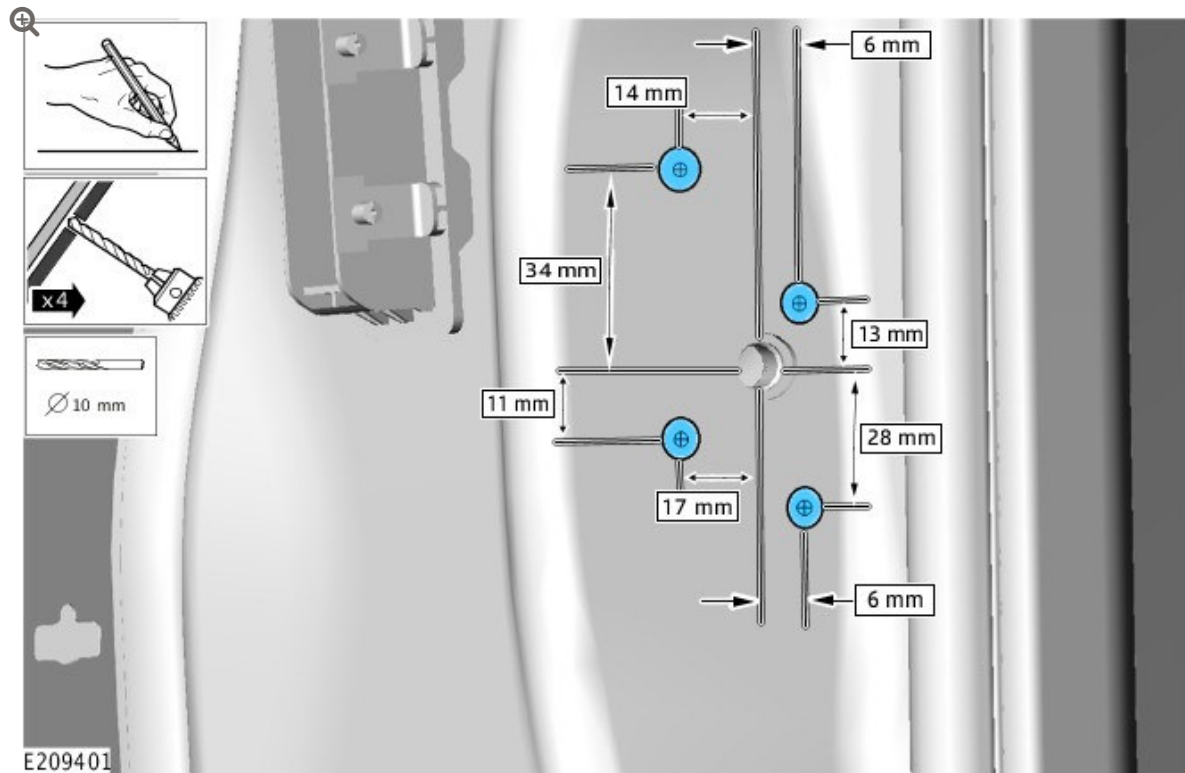

Mark out the center positions and drill four (4) 10mm-diameter holes through the outer skin of the B-Pillar in the positions highlighted.



Remove and discard the masking tape from the area highlighted.

6

WARNING:

Make sure to wear suitable personal protective equipment.

CAUTION:

Make sure to protect the surrounding area when welding to prevent damage.

NOTE:

Complete the welds in the sequence indicated, 1 - 2 - 3 - 4, allowing 3 minutes between welds to allow heat to dissipate from the area.

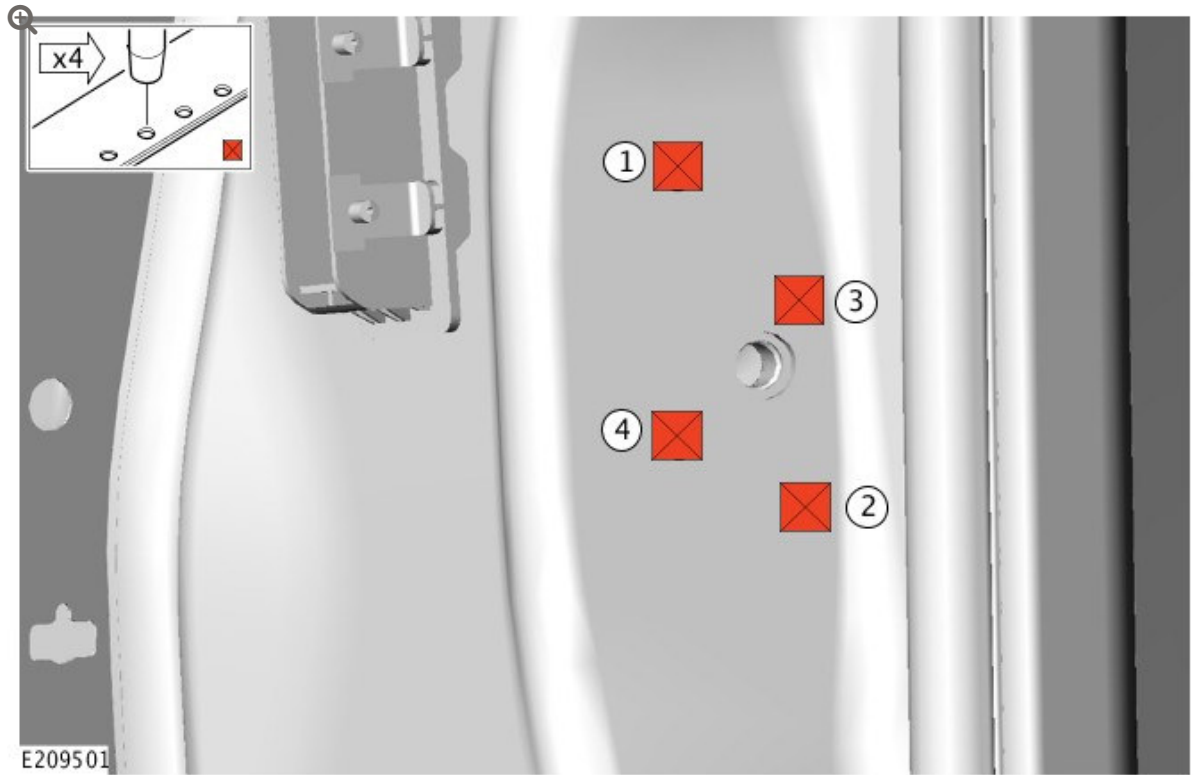

Aluminum plug weld the 4 holes to join the outer B-Pillar body panel to the inner B-Pillar body panel.

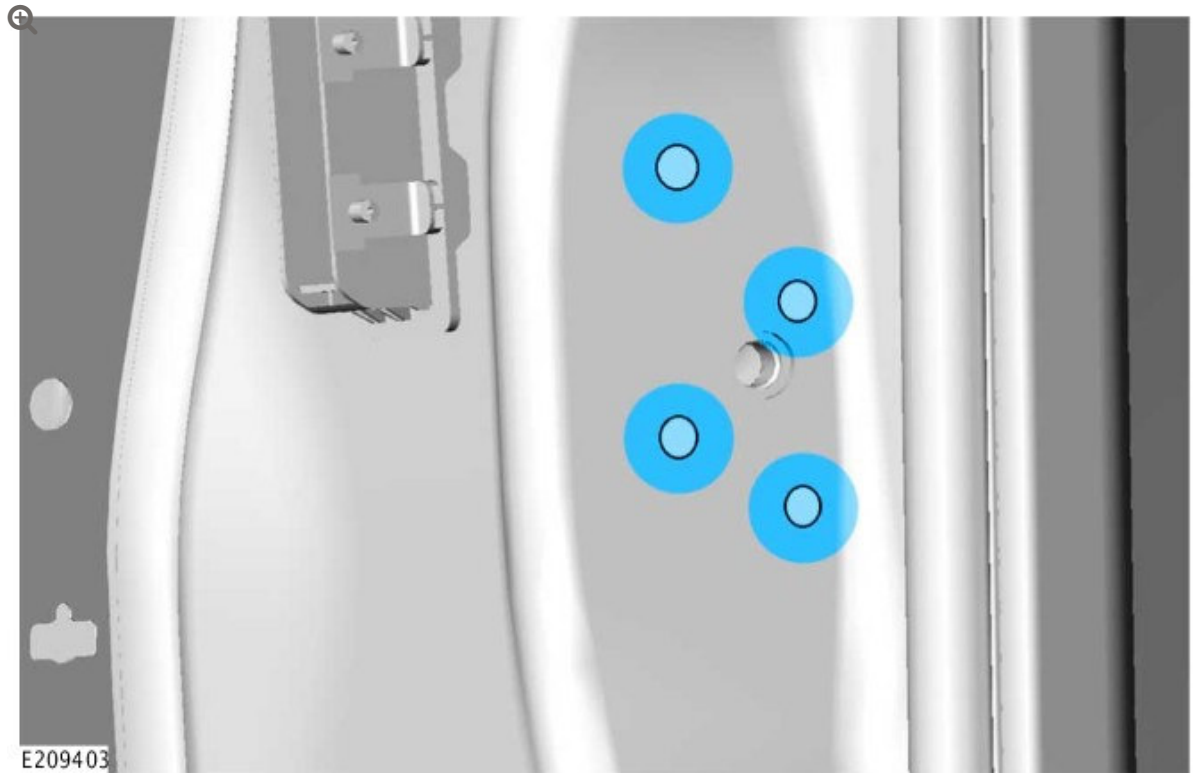

Finish the welds, clean the re-worked area, and prepare for paint.

8 **Only if required:** repeat steps 1-7 on the opposite side of the vehicle.

9 **WARNING:**

Make sure to wear suitable personal protective equipment.

CAUTION:

Make sure to mask off all the surrounding areas on the vehicle before painting.

Paint the reworked area(s).

10 Remove and discard the masking tape and materials which are sealing the door aperture(s).

11 Install the rear door(s) (see TOPIx Workshop Manual section 501-03: Body Closures).

12 Before releasing the vehicle, the following points must be explained to the customer.

- This Technical Bulletin will eliminate any A-Pillar and/or B-Pillar creaks which can be heard during the door opening cycle up to the point just before it is fully opened.
- A creak sound when the doors reach the fully opened position is normal and is to be expected. This is due to the door check arm pulling on and flexing the A-Pillar and/or B-Pillar.