

Subject:

WARNING LIGHT ILLUMINATION OR OTHER SYMPTOMS DUE TO DAMAGED OCCUPANCY SENSOR HARNESS

Bulletin No.: 09-040/17

Last Issued: 10/12/2017

APPLICABLE MODEL(S)/VINS

2016 CX-5 vehicles with VINs between JM3 KE ***** 600001-752233 (produced before December 09, 2015)

DESCRIPTION

Some vehicles may experience one or more of the following symptoms:

- Poor power steering condition and 3 or more warning lights illumination.
- Turn signal malfunction and 5 or more warning lights illumination.
- Some warning lights illumination

The front passenger seat harness (A) may be damaged by internal seat frame (B) weld spatter. Image below shows possible area of weld spatter (C).

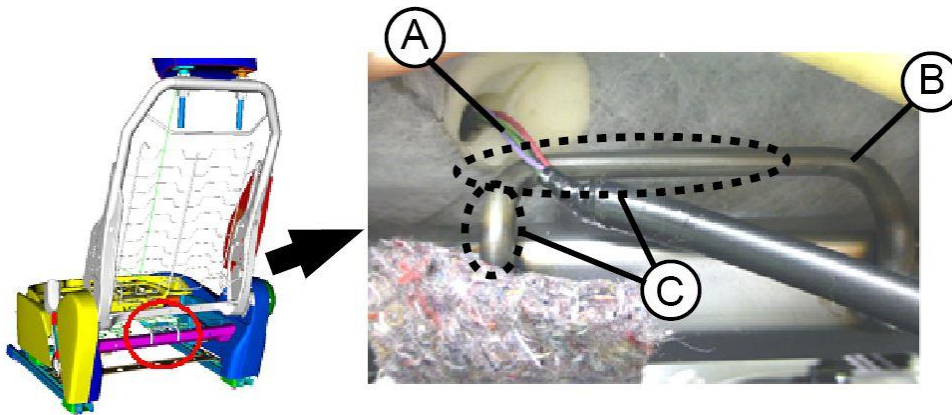

Example of weld spatter (C)

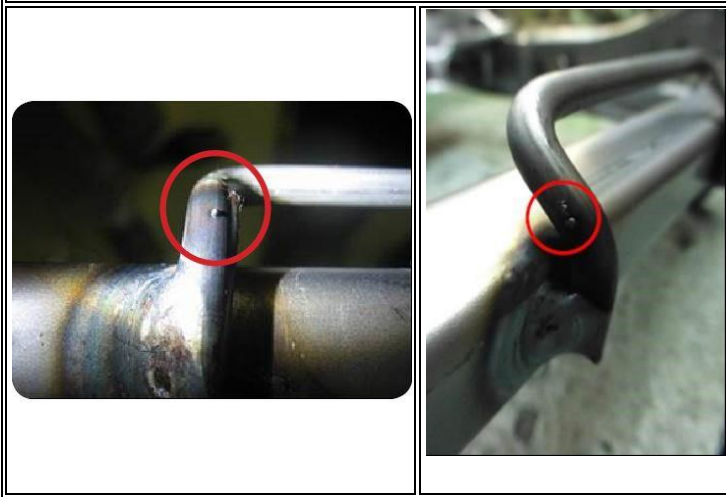

Customers having this concern should have their vehicle repaired using the following repair procedure.

REPAIR PROCEDURE

1. Verify customer concern.
2. Print a copy of the "Log Viewer" screen on M-MDS and attach it to the repair order.
3. Move the front passenger seat to upper-most and rear-most position.

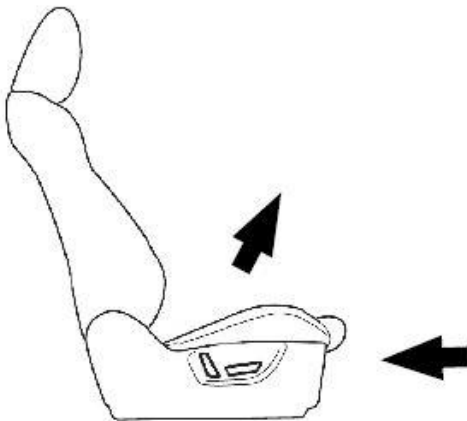

CONSUMER NOTICE: The information and instructions in this bulletin are intended for use by skilled technicians. Mazda technicians utilize the proper tools/equipment and take training to correctly and safely maintain Mazda vehicles. These instructions should not be performed by "do-it-yourselfers." Customers should not assume this bulletin applies to their vehicle or that their vehicle will develop the described concern. To determine if the information applies, customers should contact their nearest authorized Mazda dealership. Mazda North American Operations reserves the right to alter the specifications and contents of this bulletin without obligation or advance notice. All rights reserved. No part of this bulletin may be reproduced in any form or by any means, electronic or mechanical---including photocopying and recording and the use of any kind of information storage and retrieval system ---without permission in writing.

4. Remove the outer trim from the front side.

CAUTION: Wear protective gloves to avoid injury by edges of the frame.

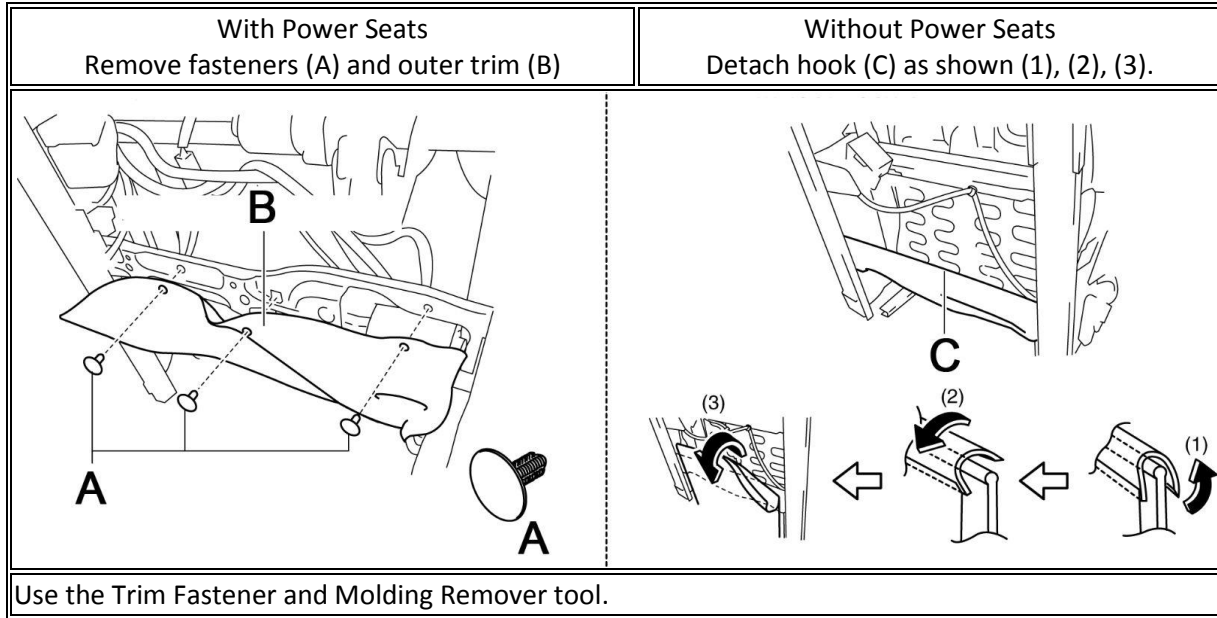

5. Move the passenger seat to upper-most and front-most position. Tilt the seat back forward.

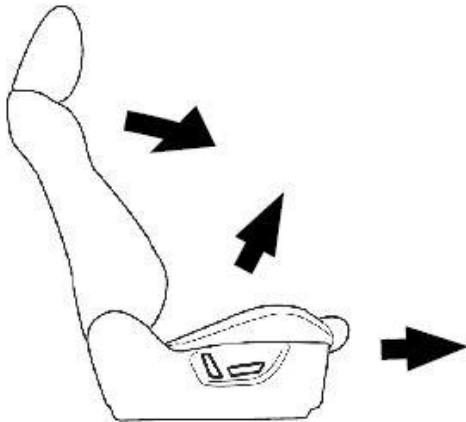

CONSUMER NOTICE: The information and instructions in this bulletin are intended for use by skilled technicians. Mazda technicians utilize the proper tools/equipment and take training to correctly and safely maintain Mazda vehicles. These instructions should not be performed by "do-it-yourselfers." Customers should not assume this bulletin applies to their vehicle or that their vehicle will develop the described concern. To determine if the information applies, customers should contact their nearest authorized Mazda dealership. Mazda North American Operations reserves the right to alter the specifications and contents of this bulletin without obligation or advance notice. All rights reserved. No part of this bulletin may be reproduced in any form or by any means, electronic or mechanical---including photocopying and recording and the use of any kind of information storage and retrieval system ---without permission in writing.

6. Remove the inner trim (D) from the bottom back of the cushion.

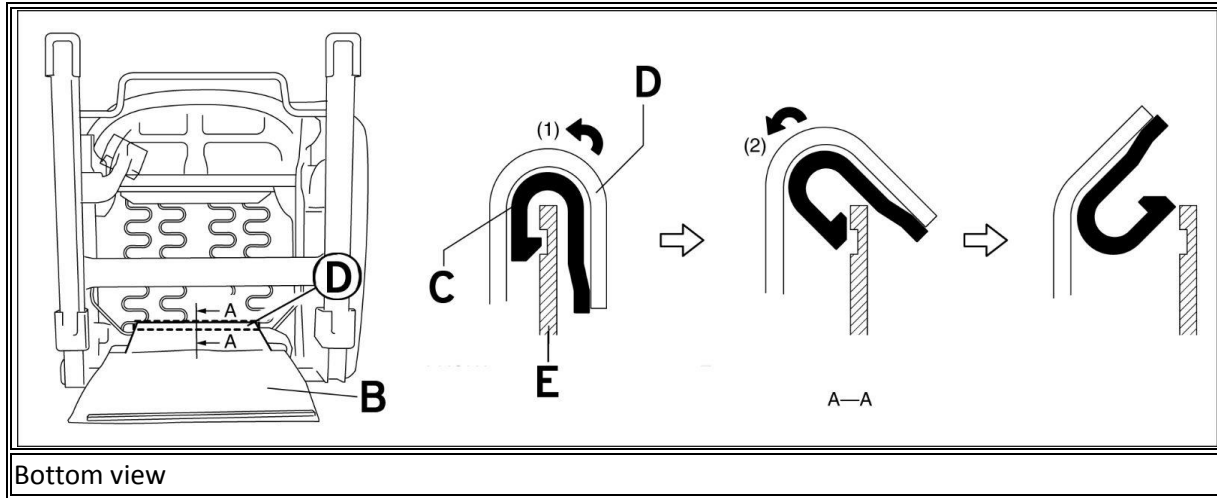

Move the hook (C) in the order of arrows (1) and (2). Set the inner trim (D) away from the front seat cushion frame (E). If it is difficult to remove the hook of the inner trim because of its tension, roll and grab the outer trim (B) and gently pull down to reduce the tension of the inner trim.





CONSUMER NOTICE: The information and instructions in this bulletin are intended for use by skilled technicians. Mazda technicians utilize the proper tools/equipment and take training to correctly and safely maintain Mazda vehicles. These instructions should not be performed by "do-it-yourselfers." Customers should not assume this bulletin applies to their vehicle or that their vehicle will develop the described concern. To determine if the information applies, customers should contact their nearest authorized Mazda dealership. Mazda North American Operations reserves the right to alter the specifications and contents of this bulletin without obligation or advance notice. All rights reserved. No part of this bulletin may be reproduced in any form or by any means, electronic or mechanical---including photocopying and recording and the use of any kind of information storage and retrieval system ---without permission in writing.

7. Check wire harness insulation for damage on all four (4) colored wires.

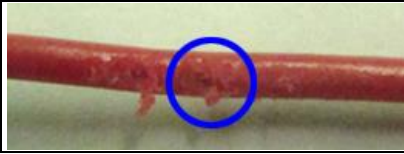

Examples of wire damage.

Wire image	Condition	Note
	Wire insulation is scratched and pin hole(s) is/are visible.	If no wire damage is found, this service bulletin does not apply. Go to normal Workshop Manual diagnosis.
	Lead wire strands are exposed.	
	Lead wire strands are broken.	

CONSUMER NOTICE: The information and instructions in this bulletin are intended for use by skilled technicians. Mazda technicians utilize the proper tools/equipment and take training to correctly and safely maintain Mazda vehicles. These instructions should not be performed by "do-it-yourselfers." Customers should not assume this bulletin applies to their vehicle or that their vehicle will develop the described concern. To determine if the information applies, customers should contact their nearest authorized Mazda dealership. Mazda North American Operations reserves the right to alter the specifications and contents of this bulletin without obligation or advance notice. All rights reserved. No part of this bulletin may be reproduced in any form or by any means, electronic or mechanical---including photocopying and recording and the use of any kind of information storage and retrieval system ---without permission in writing.

8. Apply the felt pad.

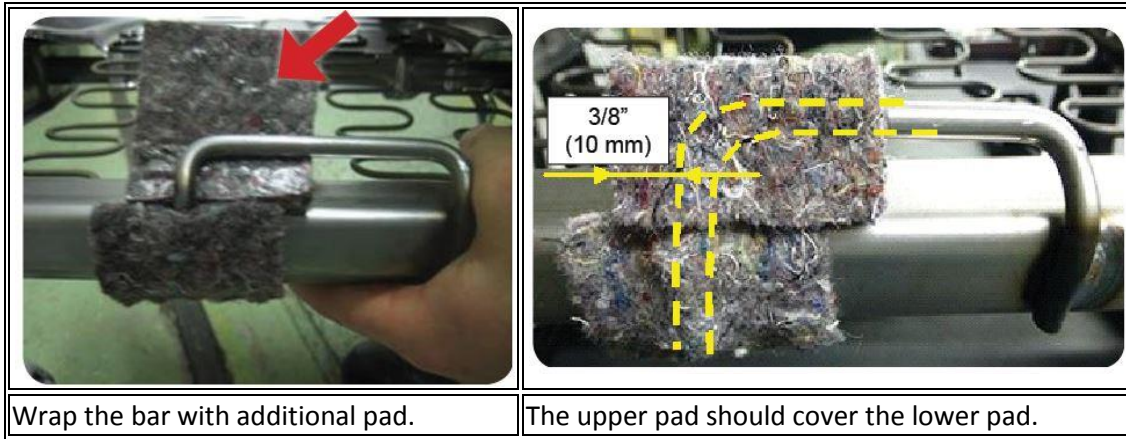

9. Replace the front passenger seat cushion with occupancy sensor. Refer to MGSS online Workshop Manual FRONT SEAT CUSHION TRIM REMOVAL/INSTALLATION.

- 10. Install the inner and outer trims.
 - a. Pull the inner trim (D) in the direction of the arrow shown. Remove the wrinkles on the front seat cushion trim.

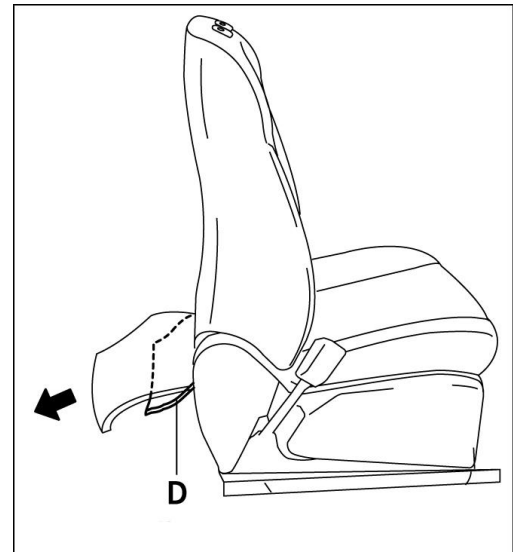

CONSUMER NOTICE: The information and instructions in this bulletin are intended for use by skilled technicians. Mazda technicians utilize the proper tools/equipment and take training to correctly and safely maintain Mazda vehicles. These instructions should not be performed by "do-it-yourselfers." Customers should not assume this bulletin applies to their vehicle or that their vehicle will develop the described concern. To determine if the information applies, customers should contact their nearest authorized Mazda dealership. Mazda North American Operations reserves the right to alter the specifications and contents of this bulletin without obligation or advance notice. All rights reserved. No part of this bulletin may be reproduced in any form or by any means, electronic or mechanical---including photocopying and recording and the use of any kind of information storage and retrieval system ---without permission in writing.

b. Move the hook (C) in the order of arrows (1) and (2) shown. Install the inner trim (D) to the front seat cushion frame (E).

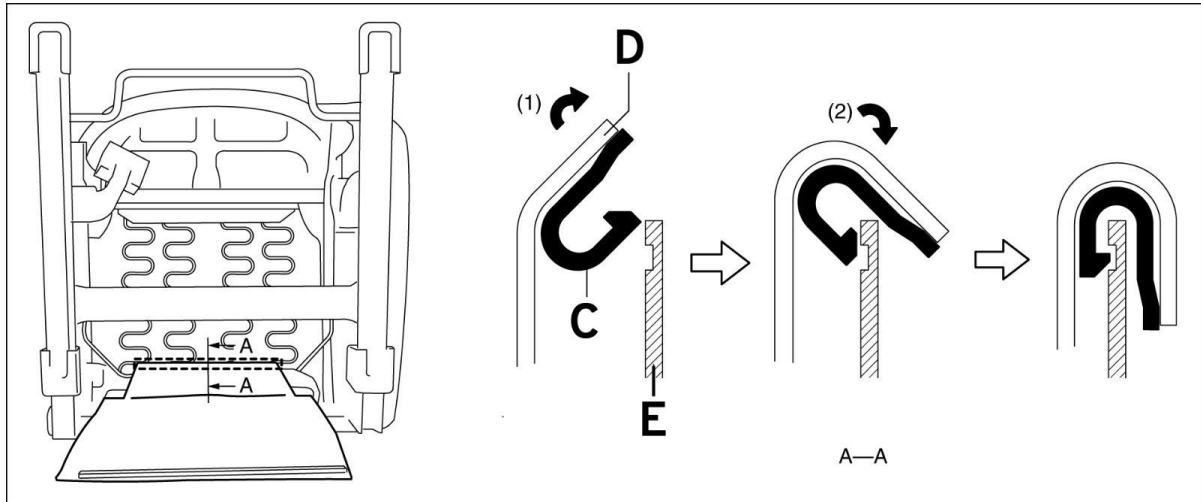

c. Pull the outer trim (B) in the direction of the arrow shown. Remove the wrinkles on the front seat cushion trim.

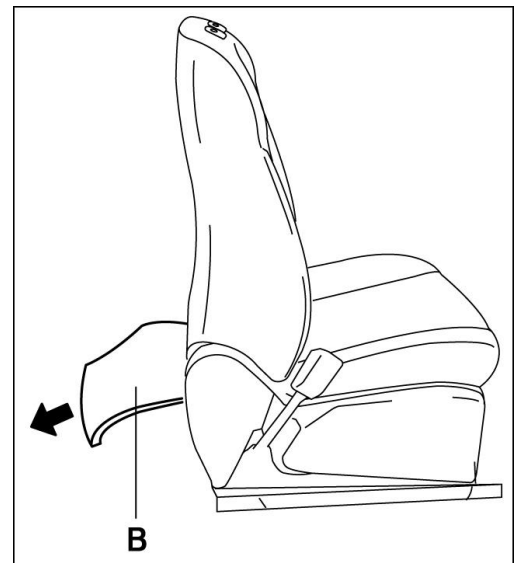

CONSUMER NOTICE: The information and instructions in this bulletin are intended for use by skilled technicians. Mazda technicians utilize the proper tools/equipment and take training to correctly and safely maintain Mazda vehicles. These instructions should not be performed by "do-it-yourselfers." Customers should not assume this bulletin applies to their vehicle or that their vehicle will develop the described concern. To determine if the information applies, customers should contact their nearest authorized Mazda dealership. Mazda North American Operations reserves the right to alter the specifications and contents of this bulletin without obligation or advance notice. All rights reserved. No part of this bulletin may be reproduced in any form or by any means, electronic or mechanical---including photocopying and recording and the use of any kind of information storage and retrieval system ---without permission in writing.

d. With Power Seat System

Install the fasteners (A) and the outer trim (B) to the front seat cushion frame.

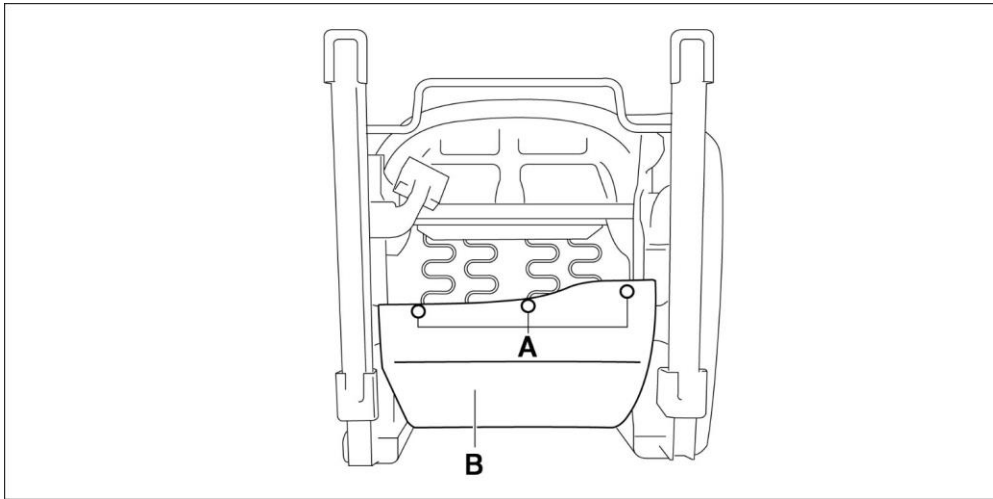

e. Without Power Seat System

Move the hook (C) in the order of arrows (1) and (2) shown. Install the front seat cushion trim (B) to the front seat cushion frame (E).

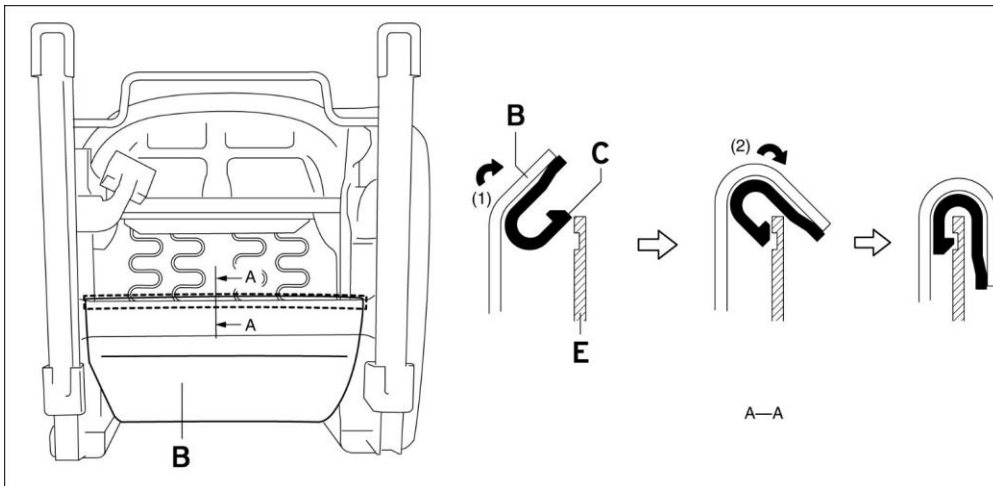

CONSUMER NOTICE: The information and instructions in this bulletin are intended for use by skilled technicians. Mazda technicians utilize the proper tools/equipment and take training to correctly and safely maintain Mazda vehicles. These instructions should not be performed by "do-it-yourselfers." Customers should not assume this bulletin applies to their vehicle or that their vehicle will develop the described concern. To determine if the information applies, customers should contact their nearest authorized Mazda dealership. Mazda North American Operations reserves the right to alter the specifications and contents of this bulletin without obligation or advance notice. All rights reserved. No part of this bulletin may be reproduced in any form or by any means, electronic or mechanical---including photocopying and recording and the use of any kind of information storage and retrieval system ---without permission in writing.

11. Confirm that the cushion pad is not exposed. Correct if necessary.





12. Check for wrinkles on the surface of the seat cushion and correct if necessary. Correct seat surface position if necessary.



13. Verify repair.

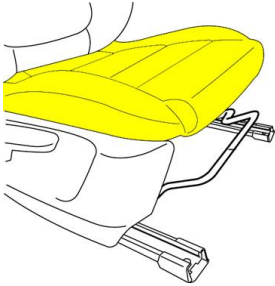

CONSUMER NOTICE: The information and instructions in this bulletin are intended for use by skilled technicians. Mazda technicians utilize the proper tools/equipment and take training to correctly and safely maintain Mazda vehicles. These instructions should not be performed by "do-it-yourselfers." Customers should not assume this bulletin applies to their vehicle or that their vehicle will develop the described concern. To determine if the information applies, customers should contact their nearest authorized Mazda dealership. Mazda North American Operations reserves the right to alter the specifications and contents of this bulletin without obligation or advance notice. All rights reserved. No part of this bulletin may be reproduced in any form or by any means, electronic or mechanical---including photocopying and recording and the use of any kind of information storage and retrieval system ---without permission in writing.

PARTS INFORMATION

Parts Number	Description	Qty.	Notes
U009-88-0A9 -52	PAD, SPACER	1	Felt pad 
KA0*-88-11XA	CUSHION (R),FRT SEAT	1	Use GEPC with VIN for correct part number 
G032-68-865A-00	FASTENER	1-3	With Power Seat Only replace if damaged 

CONSUMER NOTICE: The information and instructions in this bulletin are intended for use by skilled technicians. Mazda technicians utilize the proper tools/equipment and take training to correctly and safely maintain Mazda vehicles. These instructions should not be performed by "do-it-yourselfers." Customers should not assume this bulletin applies to their vehicle or that their vehicle will develop the described concern. To determine if the information applies, customers should contact their nearest authorized Mazda dealership. Mazda North American Operations reserves the right to alter the specifications and contents of this bulletin without obligation or advance notice. All rights reserved. No part of this bulletin may be reproduced in any form or by any means, electronic or mechanical---including photocopying and recording and the use of any kind of information storage and retrieval system ---without permission in writing.

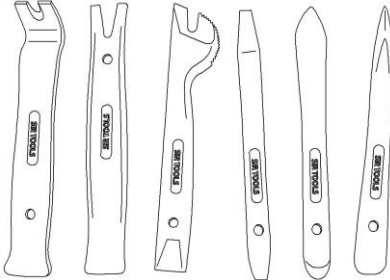
TOOLS

Parts Number	Description	Image
Locally sourced	Trim Fastener and Molding Remover Set	
Locally sourced	Gloves	
Locally sourced	Flash light	

CONSUMER NOTICE: The information and instructions in this bulletin are intended for use by skilled technicians. Mazda technicians utilize the proper tools/equipment and take training to correctly and safely maintain Mazda vehicles. These instructions should not be performed by "do-it-yourselfers." Customers should not assume this bulletin applies to their vehicle or that their vehicle will develop the described concern. To determine if the information applies, customers should contact their nearest authorized Mazda dealership. Mazda North American Operations reserves the right to alter the specifications and contents of this bulletin without obligation or advance notice. All rights reserved. No part of this bulletin may be reproduced in any form or by any means, electronic or mechanical---including photocopying and recording and the use of any kind of information storage and retrieval system ---without permission in writing.

WARRANTY INFORMATION**NOTE:**

- This warranty information applies only to verified customer complaints on vehicles eligible for warranty repair.
- This repair will be covered under Mazda's New Vehicle Limited Warranty term.
- This claim only applies to vehicles with wire damage.
- Additional diagnostic time cannot be claimed for this repair.
- IDS Log Viewer with all DTC fault codes requires attachment code D01 and will be reviewed.
- If this bulletin does not apply (step 7. shows no wire damage), claim necessary repair as follows:

- Use Labor operation Z0001XDX for actual time.

- Use PNMC of the part found to be failed.

	Add felt pad and replace the front passenger seat cushion
Warranty Type	A
Symptom Code	6X
Damage Code	9Q
Part Number Main Cause	U009-88-0A9 52
Quantity	1
Operation Number / Labor Hours:	XXM4ZXRX / 1.0 Hrs.

NOTE: Claim the replaced parts as related parts.

CONSUMER NOTICE: The information and instructions in this bulletin are intended for use by skilled technicians. Mazda technicians utilize the proper tools/equipment and take training to correctly and safely maintain Mazda vehicles. These instructions should not be performed by "do-it-yourselfers." Customers should not assume this bulletin applies to their vehicle or that their vehicle will develop the described concern. To determine if the information applies, customers should contact their nearest authorized Mazda dealership. Mazda North American Operations reserves the right to alter the specifications and contents of this bulletin without obligation or advance notice. All rights reserved. No part of this bulletin may be reproduced in any form or by any means, electronic or mechanical---including photocopying and recording and the use of any kind of information storage and retrieval system ---without permission in writing.