

# Technical Service Bulletin

Mazda North American Operations  
Irvine, CA 92618-2922



<b>Subject:</b>  <b>CREAKING NOISE FROM FRONT LOWER ARM BUSHING / CLUNKING NOISE FROM FRONT SHOCK ABSORBER COIL SPRING WHEN DRIVING OVER BUMPS</b>	<b>Bulletin No.:</b> 02-007/17
	<b>Last Issued:</b> 10/06/2017

## BULLETIN NOTES

This bulletin supersedes the previously issued bulletin(s) listed below. The changes are noted in Red text.

Previous TSBs:	Date(s) Issued:
02-007/17	06/09/17

## DESCRIPTION

APPLICABLE MODEL(S)/VINS  
2016-2017 CX-9

Some vehicles may exhibit one or **more** of the following noises from the front suspension:

1. A creaking noise from under the front of the vehicle (front lower arm bushing) when driving over bumps at approximate 12 - 25 mph (20 - 40 Km/h). The noise occurs when the road surface is wet or after the vehicle has been washed. The noise becomes more noticeable as the bumps get higher. The creaking noise is caused by the front lower arm bushing (A) making a stick-slip noise during wet road conditions.
2. A clunking noise from the front coil spring when driving over bumps. The clunking noise is due to stick-slip between the front strut bearing (B) and the coil spring (C).
3. A popping noise from the bump stopper (D) when driving through gutters.

**CONSUMER NOTICE:** The information and instructions in this bulletin are intended for use by skilled technicians. Mazda technicians utilize the proper tools/equipment and take training to correctly and safely maintain Mazda vehicles. These instructions should not be performed by "do-it-yourselfers." Customers should not assume this bulletin applies to their vehicle or that their vehicle will develop the described concern. To determine if the information applies, customers should contact their nearest authorized Mazda dealership. Mazda North American Operations reserves the right to alter the specifications and contents of this bulletin without obligation or advance notice. All rights reserved. No part of this bulletin may be reproduced in any form or by any means, electronic or mechanical---including photocopying and recording and the use of any kind of information storage and retrieval system ---without permission in writing.

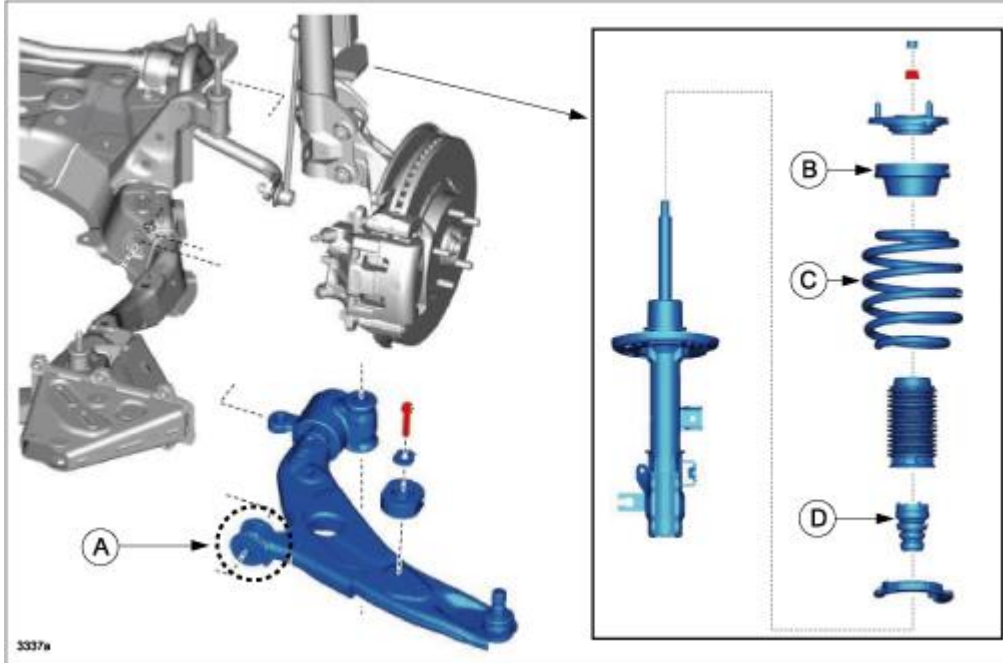

To eliminate the noise, the following mass-production changes have been made:

1. The coating treatment of the lower arm bushing has been changed to reduce friction and prevent stick-slip.
2. Protectors have been installed onto the coil springs to prevent stick-slip.
3. No mass-production change is scheduled for the bump stopper, however, a modified service part has been established.

Modification	Starting VIN	Mass-Production Date
Change of Lower Arm Bushing	JM3TC*****127909	Nov. 8, 2016
Installation of Protectors onto Coil Spring	JM3TC*****137841	Feb. 6, 2017
<b>Bump Stopper</b>	<b>None</b>	<b>None</b>

Customers having this concern should have their vehicle repaired using the following repair procedure.

**CONSUMER NOTICE:** The information and instructions in this bulletin are intended for use by skilled technicians. Mazda technicians utilize the proper tools/equipment and take training to correctly and safely maintain Mazda vehicles. These instructions should not be performed by "do-it-yourselfers." Customers should not assume this bulletin applies to their vehicle or that their vehicle will develop the described concern. To determine if the information applies, customers should contact their nearest authorized Mazda dealership. Mazda North American Operations reserves the right to alter the specifications and contents of this bulletin without obligation or advance notice. All rights reserved. No part of this bulletin may be reproduced in any form or by any means, electronic or mechanical---including photocopying and recording and the use of any kind of information storage and retrieval system ---without permission in writing.

## REPAIR OUTLINE

Use Special Service Tools (SST) ChassisEAR / EngineEAR II Combo JSP06608 **or** Wireless ChassisEAR JSP97202 to confirm noise is coming from the front suspension when driving over bumps:

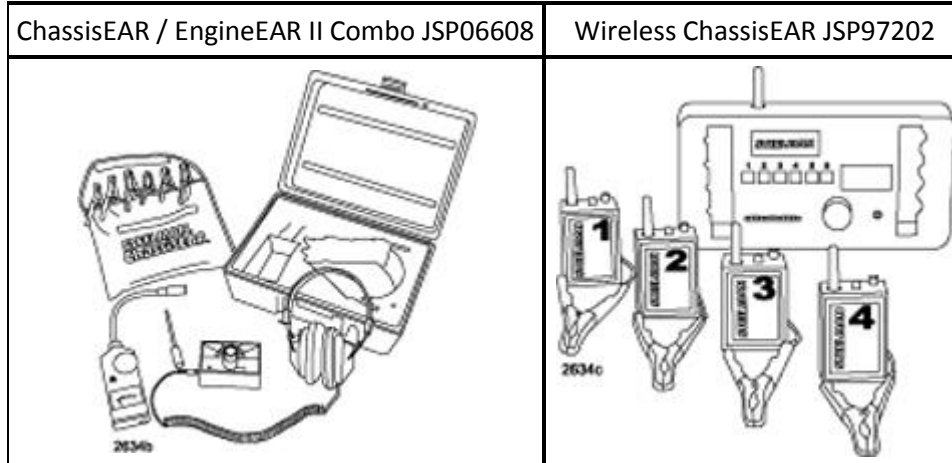

**NOTE:** SST JSP06608 and JSP97202 are available for purchase on Mazda E-Store.

**NOTE:**

- For removal/installation and disassembly/assembly of the front shock absorber, refer to the instructions on MGSS online (FRONT SHOCK ABSORBER AND COIL SPRING DISASSEMBLY/ASSEMBLY).
- Before removing the mounting rubber, put the position mark so the mounting rubber can be installed back in the original position.

**CAUTION:** It is not necessary to adjust the front wheel alignment because the front shock absorber and the mounting rubber are not replaced. However, make sure to install the mounting rubber to the original position.

**CONSUMER NOTICE:** The information and instructions in this bulletin are intended for use by skilled technicians. Mazda technicians utilize the proper tools/equipment and take training to correctly and safely maintain Mazda vehicles. These instructions should not be performed by "do-it-yourselfers." Customers should not assume this bulletin applies to their vehicle or that their vehicle will develop the described concern. To determine if the information applies, customers should contact their nearest authorized Mazda dealership. Mazda North American Operations reserves the right to alter the specifications and contents of this bulletin without obligation or advance notice. All rights reserved. No part of this bulletin may be reproduced in any form or by any means, electronic or mechanical---including photocopying and recording and the use of any kind of information storage and retrieval system ---without permission in writing.

## REPAIR PROCEDURE

1. Verify the customer concern.
2. Determine the vehicle type (A, B or C) by using the table below.

Vehicle Type	VIN Range	Lower Arm Bushing Repair (Both Sides)	Protector For Coil Spring (Both Sides)	Bump Stopper (Both sides)
A	100001 - 127908	Replace with modified parts	Install protector	Replace with modified service part
B	127909 - 137841	DO NOT replace parts	Install protector	Replace with modified service part
C	137842 - 999999	DO NOT replace parts	NOT necessary to install	Replace with modified service part

### Repair 1 (For Vehicle Type A Only): Replace lower arm bushing with modified part (both sides)

1. Remove the front lower arm assembly (both sides) according to the instructions on MGSS online (FRONT LOWER ARM REMOVAL/INSTALLATION).
2. Remove the front lower arm bushing using the SSTs.

Set SSTs (49 G030 797 and 49 US16 004) and the front lower arm on a shop press (as shown below) and remove the front lower arm bushing.

**SST Dimensions:** Outer Diameter: 56mm, Inner Diameter: 50mm, Height: 40mm

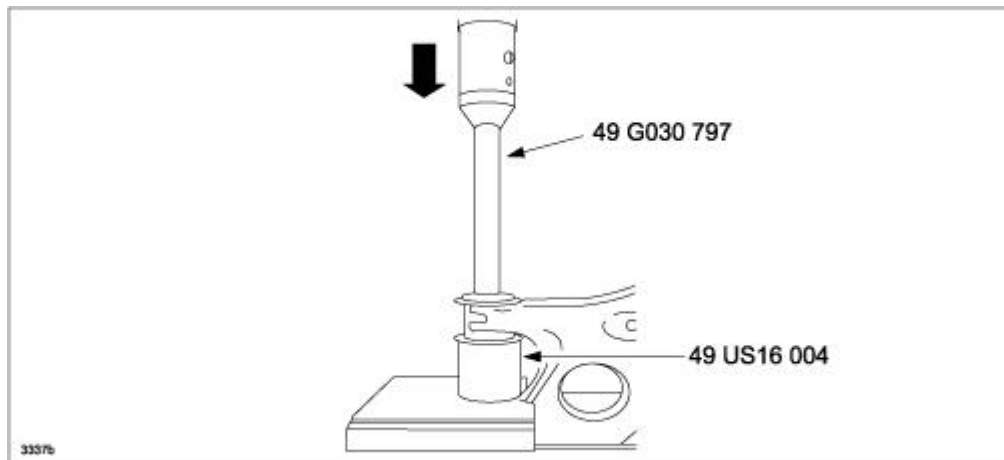

**CONSUMER NOTICE:** The information and instructions in this bulletin are intended for use by skilled technicians. Mazda technicians utilize the proper tools/equipment and take training to correctly and safely maintain Mazda vehicles. These instructions should not be performed by "do-it-yourselfers." Customers should not assume this bulletin applies to their vehicle or that their vehicle will develop the described concern. To determine if the information applies, customers should contact their nearest authorized Mazda dealership. Mazda North American Operations reserves the right to alter the specifications and contents of this bulletin without obligation or advance notice. All rights reserved. No part of this bulletin may be reproduced in any form or by any means, electronic or mechanical---including photocopying and recording and the use of any kind of information storage and retrieval system ---without permission in writing.

3. Install the new modified front lower arm bushing using SSTs.

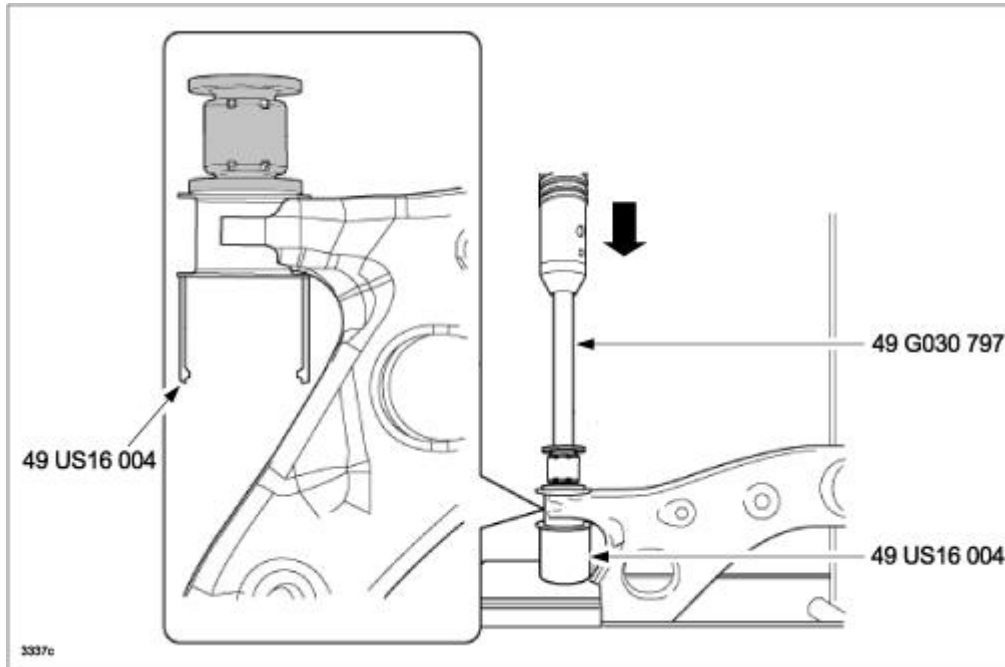

**NOTE :**

- Apply soap suds to the new bushing to facilitate installation.
- Before installing the new bushing, wipe the inside of the outer tube and make sure it is clean.
- If soap suds get in the inner pipe of the new bushing, wipe it off using a cloth.

**CAUTION:** Make sure that the new bushing has been properly inserted by checking that the tab of the bushing is completely expanded (as shown below left).

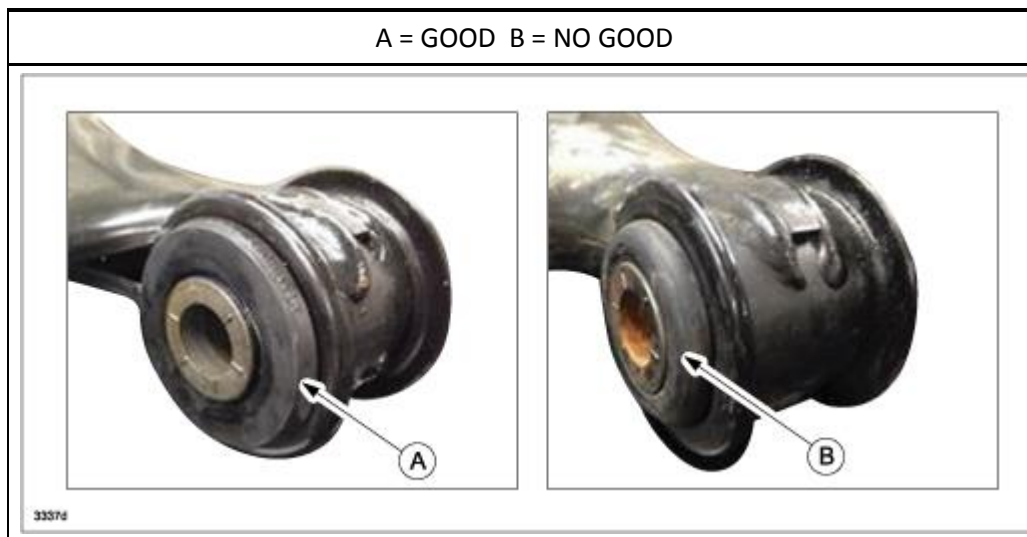

**CONSUMER NOTICE:** The information and instructions in this bulletin are intended for use by skilled technicians. Mazda technicians utilize the proper tools/equipment and take training to correctly and safely maintain Mazda vehicles. These instructions should not be performed by "do-it-yourselfers." Customers should not assume this bulletin applies to their vehicle or that their vehicle will develop the described concern. To determine if the information applies, customers should contact their nearest authorized Mazda dealership. Mazda North American Operations reserves the right to alter the specifications and contents of this bulletin without obligation or advance notice. All rights reserved. No part of this bulletin may be reproduced in any form or by any means, electronic or mechanical---including photocopying and recording and the use of any kind of information storage and retrieval system ---without permission in writing.

4. Verify that the new bushing is installed in the correct position by measuring the protruded part (A - B) as shown below.

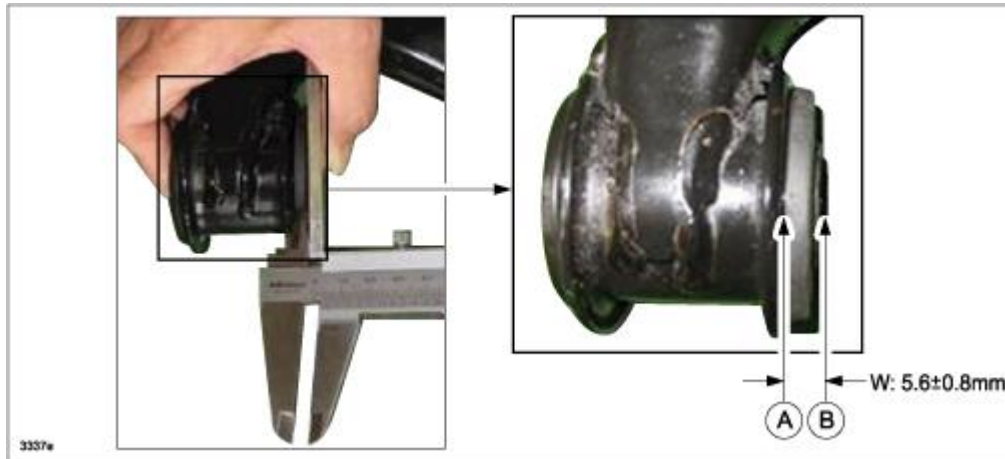

**Width of protrusion: 5.6 +/- 0.8mm (0.22 +/- 0.03 in)**

5. Install the front lower arm assembly (both sides) to the vehicle according to the instructions on MGSS online (FRONT LOWER ARM REMOVAL/INSTALLATION).

**NOTE:** For the joint sections with rubber bushings, raise the vehicle using a lift, and then temporarily tighten the installation bolts. Then raise the vehicle using a wheel alignment lift rack (A) or lower the vehicle to the ground (to load the suspension). Use a torque wrench (B) to tighten the bolts (C) to the specified tightening torque.

**CONSUMER NOTICE:** The information and instructions in this bulletin are intended for use by skilled technicians. Mazda technicians utilize the proper tools/equipment and take training to correctly and safely maintain Mazda vehicles. These instructions should not be performed by "do-it-yourselfers." Customers should not assume this bulletin applies to their vehicle or that their vehicle will develop the described concern. To determine if the information applies, customers should contact their nearest authorized Mazda dealership. Mazda North American Operations reserves the right to alter the specifications and contents of this bulletin without obligation or advance notice. All rights reserved. No part of this bulletin may be reproduced in any form or by any means, electronic or mechanical---including photocopying and recording and the use of any kind of information storage and retrieval system ---without permission in writing.

Mazda6 shown below as an example:

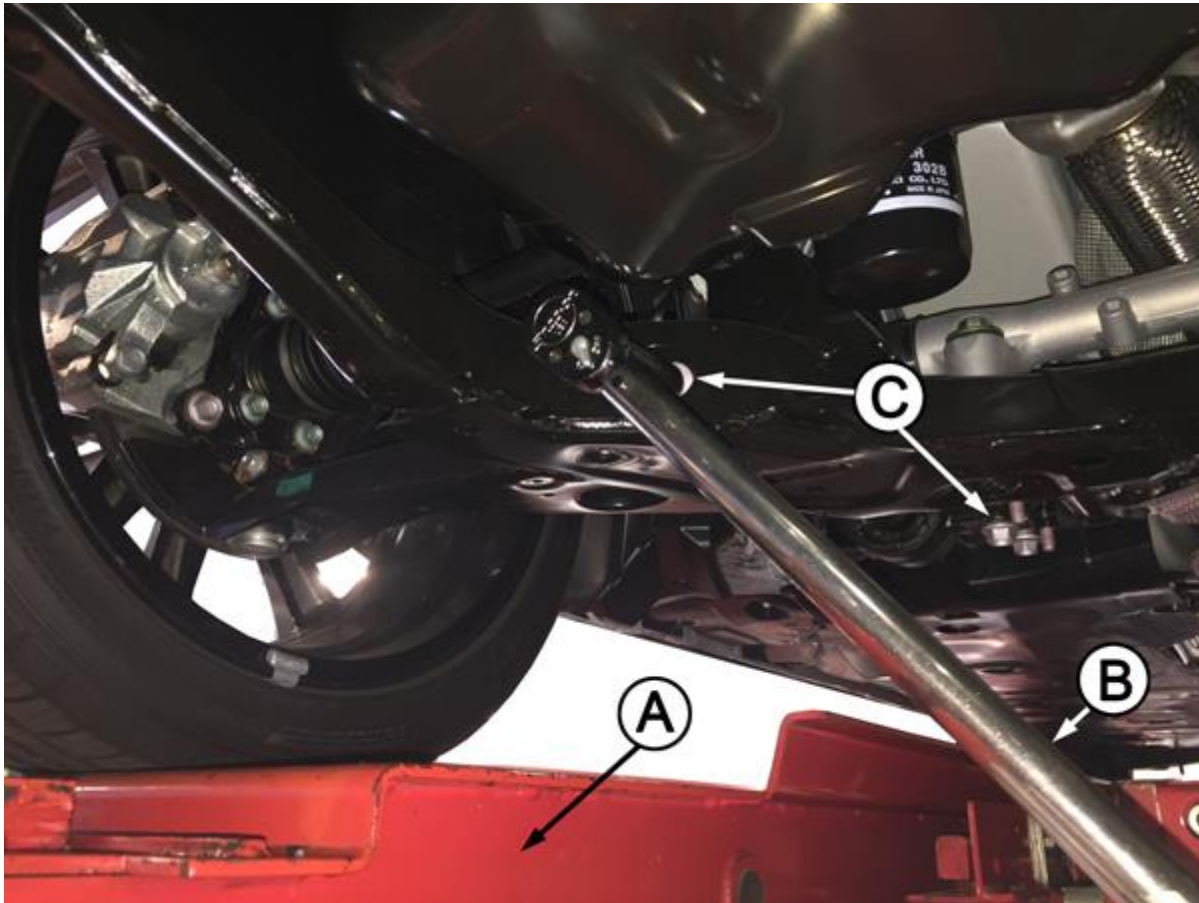

6. Inspect the front wheel alignment and adjust it if necessary according to the instructions on MGSS online (FRONT WHEEL ALIGNMENT).
7. Verify the repair.

**Repair 2 (For Vehicle Type A and B):** Install protector onto coil spring and replace bump stopper with modified service part (both sides)

1. Remove the coil spring of the front shock absorbers (both sides) according to the instructions on MGSS online (FRONT SHOCK ABSORBER AND COIL SPRING REMOVAL/INSTALLATION).

**NOTE:** When the lower arm bushings are not replaced, perform the following step so that a front wheel alignment not unnecessary.

Put a position mark before removing the mounting rubber, so the mounting rubber can be reinstalled back to the original position. If this is done, it won't be necessary to perform a front wheel alignment because the front shock absorber and the mounting rubber were not replaced.

**CONSUMER NOTICE:** The information and instructions in this bulletin are intended for use by skilled technicians. Mazda technicians utilize the proper tools/equipment and take training to correctly and safely maintain Mazda vehicles. These instructions should not be performed by "do-it-yourselfers." Customers should not assume this bulletin applies to their vehicle or that their vehicle will develop the described concern. To determine if the information applies, customers should contact their nearest authorized Mazda dealership. Mazda North American Operations reserves the right to alter the specifications and contents of this bulletin without obligation or advance notice. All rights reserved. No part of this bulletin may be reproduced in any form or by any means, electronic or mechanical---including photocopying and recording and the use of any kind of information storage and retrieval system ---without permission in writing.

2. Degrease one turn of the spring from the top.
3. Install the protector onto the coil spring aligning the end of the protector as shown below.

**NOTE:** Install the protector so that the gap (A) is: **4.5 +/- 4.0mm (0.177 +/- 0.157 in)**

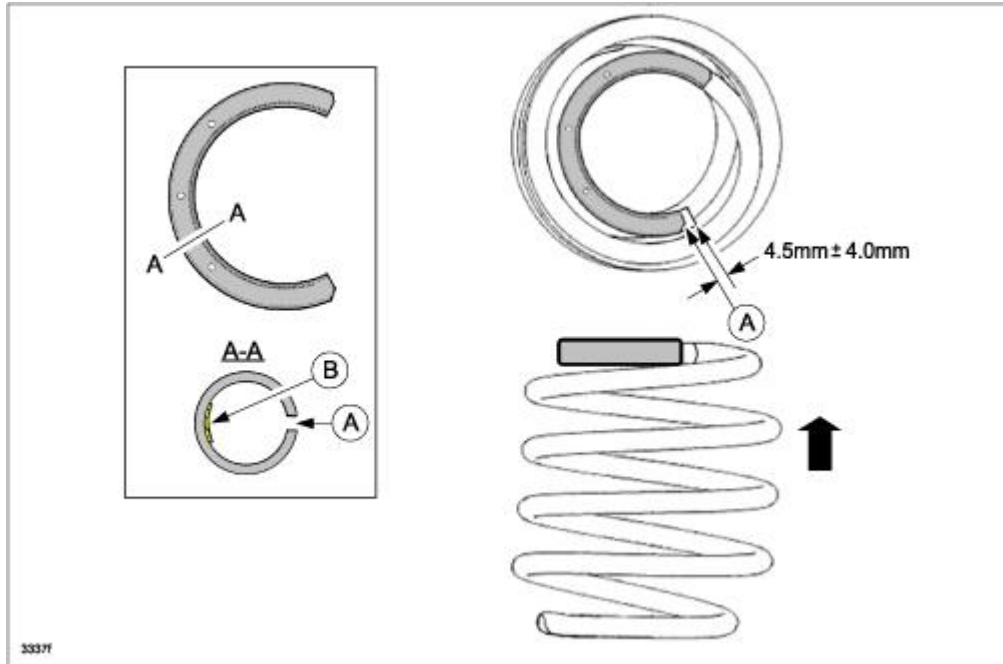

4. The inner side of the protector contains adhesive glue (B), so, after the installation, press on the protector to adhere it to the spring.
5. **Using the modified bump stopper**, assemble and install the shock absorbers according to the instructions on MGSS online (FRONT SHOCK ABSORBER AND COIL SPRING REMOVAL/INSTALLATION).
6. Verify the repair.

**Repair 3 (For Vehicle Type C Only): Replace the bump stopper with modified service part (both sides)**

1. **Replace the bump stopper with the modified service part (both sides) according to the instructions on MGSS online (FRONT SHOCK ABSORBER AND COIL SPRING REMOVAL/INSTALLATION).**

**NOTE:** Perform the following steps so the adjustment of the front wheel alignment is not necessary. Before removal of the mounting rubber, place a position mark on it so it can be installed back in the original position. If this has been done, it is not necessary to adjust the front wheel alignment because the front shock absorber and the mounting rubber were not replaced.

**CONSUMER NOTICE:** The information and instructions in this bulletin are intended for use by skilled technicians. Mazda technicians utilize the proper tools/equipment and take training to correctly and safely maintain Mazda vehicles. These instructions should not be performed by "do-it-yourselfers." Customers should not assume this bulletin applies to their vehicle or that their vehicle will develop the described concern. To determine if the information applies, customers should contact their nearest authorized Mazda dealership. Mazda North American Operations reserves the right to alter the specifications and contents of this bulletin without obligation or advance notice. All rights reserved. No part of this bulletin may be reproduced in any form or by any means, electronic or mechanical---including photocopying and recording and the use of any kind of information storage and retrieval system ---without permission in writing.



**PARTS INFORMATION**

Parts Number	Description	Qty.	Notes
TK48-34-470	Front Lower Arm Rubber Bushing	2	---
TKY8-34-081	Protector Tube	2	---
9YB0-41-414	Piston Rod Nut, Front Shock Absorber	2	Replace
<b>GRT7-34-111</b>	<b>Bump Stopper</b>	<b>2</b>	<b>Service part only</b>

**WARRANTY INFORMATION****NOTE:**

- This warranty information applies only to verified customer complaints on vehicles eligible for warranty repair.
- This repair will be covered under Mazda's New Vehicle Limited Warranty term.
- Additional diagnostic time cannot be claimed for this repair.

According to the **vehicle type**, use the following warranty information to submit claim(s).

Vehicle Type	Lower Arm Bushings	Protectors	Bump Stopper	Warranty Information to use
<b>A</b>	Replace	Install	Replace	Use <b>Warranty Information A</b> and <b>B</b> and <b>submit two claims separately</b>
<b>B</b>	---	Install	Replace	Use Warranty Information C only
<b>C</b>	---	---	<b>Replace</b>	<b>Use Warranty Information C only</b>

**CONSUMER NOTICE:** The information and instructions in this bulletin are intended for use by skilled technicians. Mazda technicians utilize the proper tools/equipment and take training to correctly and safely maintain Mazda vehicles. These instructions should not be performed by "do-it-yourselfers." Customers should not assume this bulletin applies to their vehicle or that their vehicle will develop the described concern. To determine if the information applies, customers should contact their nearest authorized Mazda dealership. Mazda North American Operations reserves the right to alter the specifications and contents of this bulletin without obligation or advance notice. All rights reserved. No part of this bulletin may be reproduced in any form or by any means, electronic or mechanical---including photocopying and recording and the use of any kind of information storage and retrieval system ---without permission in writing.

**A. (For Vehicle Type A Only): Replace Lower Arm Bushing with modified parts and Bump Stopper (Both Sides)**

Warranty Type	A
Symptom Code	82
Damage Code	93
Part Number Main Cause	TK48-34-470
Quantity	2
Operation Number / Labor Hours:	<p><b><u>Lower Arm Bushing, Replace (Both sides)</u></b> Select one applicable to the actual repair.</p> <p>1.Front Wheel Alignment Check Adjust was performed at sublet shop. <b>XXMBMARX, 0.9 Hrs.</b></p> <p>2.Front Wheel Alignment Check Adjust was performed at dealer using 4-Wheel Alignment Tester. <b>XXMBMBRX, 2.0 Hrs.</b></p> <p>3.Front Wheel Alignment Check Adjust is performed at dealer using 4-wheel alignment tester with Wireless Type. <b>XXMBMCRX, 1.6 Hrs.</b></p>
Sublet Code:	If Wheel Alignment Check and Adjust was performed at sublet shop, claim the actual invoice amount with the sublet code "C1".

**CONSUMER NOTICE:** The information and instructions in this bulletin are intended for use by skilled technicians. Mazda technicians utilize the proper tools/equipment and take training to correctly and safely maintain Mazda vehicles. These instructions should not be performed by "do-it-yourselfers." Customers should not assume this bulletin applies to their vehicle or that their vehicle will develop the described concern. To determine if the information applies, customers should contact their nearest authorized Mazda dealership. Mazda North American Operations reserves the right to alter the specifications and contents of this bulletin without obligation or advance notice. All rights reserved. No part of this bulletin may be reproduced in any form or by any means, electronic or mechanical---including photocopying and recording and the use of any kind of information storage and retrieval system ---without permission in writing.

**B. (For Vehicle Type A Only): Install Protectors onto Coil Springs and Bump Stopper(Both Sides)**

**NOTE:** Use this SRT when the lower arm bushings are replaced at the same time. The time for the duplicated operations incurred for both operations is reduced.

Warranty Type	A
Symptom Code	82
Damage Code	93
Part Number Main Cause	TKY8-34-081 (Protector Tube) / Qty. = 2
Quantity	2
Operation Number / Labor Hours:	XXN26ARX / 0.6 Hr. (Protector and Bump Stopper, Install (Both Sides))

**NOTE:** Enter Bump Stopper as a related part.

**C. (For Vehicle Type B): Install Protector onto Coil Springs and replace Bump Stopper with modified service parts (Both Sides)****(For Vehicle Type C): Replace Bump Stopper with modified service parts (Both Sides)**

**NOTE:** Use this SRT when the lower arm bushings are not replaced together.

**NOTE:** Use this SRT only when the protectors are installed on the springs (modified lower arm bushings are already installed on the vehicle.)

Warranty Type	A
Symptom Code	82
Damage Code	93
Part Number Main Cause	GRT7-34-111 (Bump Stopper) / Qty.= 2
Quantity	2
Operation Number / Labor Hours:	XXN26BRX / 0.9 Hr. (Protector (Vehicle Type B Only) and Bump Stopper, Install (Both Sides))

**NOTE:** Enter Protectors as related parts for Vehicle Type B.

**CONSUMER NOTICE:** The information and instructions in this bulletin are intended for use by skilled technicians. Mazda technicians utilize the proper tools/equipment and take training to correctly and safely maintain Mazda vehicles. These instructions should not be performed by "do-it-yourselfers." Customers should not assume this bulletin applies to their vehicle or that their vehicle will develop the described concern. To determine if the information applies, customers should contact their nearest authorized Mazda dealership. Mazda North American Operations reserves the right to alter the specifications and contents of this bulletin without obligation or advance notice. All rights reserved. No part of this bulletin may be reproduced in any form or by any means, electronic or mechanical---including photocopying and recording and the use of any kind of information storage and retrieval system ---without permission in writing.