

TECHNICAL INSTRUCTIONS
FOR
LIMITED SERVICE CAMPAIGN H0F
CERTAIN 2007 - 2008 MODEL YEAR TUNDRA
CORROSION-RESISTANT COMPOUND APPLICATION

COLD CLIMATE STATES ONLY

CT, DE, IL, IN, KY, MA, MD, ME, MI, MN, NH, NJ, NY, OH, PA, RI, VA, VT, WI & WV

The repair quality of covered vehicles is extremely important to Toyota. All dealership technicians performing this repair are required to successfully complete the most current version of the E-Learning course "Safety Recall and Service Campaign Essentials". To ensure that all vehicles have the repair performed correctly, technicians performing this repair are required to currently hold at least one of the following certification levels:

- Certified Technician and above

Always check which technicians can perform the recall remedy by logging on to <https://www.uotdealerreports.com>. It is the dealership's responsibility to select technicians with the above certification level or greater to perform this repair. Carefully review your resources, the technician skill level, and ability before assigning technicians to this repair. It is important to consider technician days off and vacation schedules to ensure there are properly trained technicians available to perform this repair at all times.



- For a complete list of site selection guidelines and, applicable fire, building, and zoning code information for your state, please refer to the Dealer Information Packet. Please ensure your dealership complies with all requirements and regulations set forth in the applicable Dealer Information Packets and any Supplements.
- Keep records to comply with Federal/State/Local regulations and requirements. See the Dealer Packet for C0D and any Supplements to that Guide.

I. OPERATION FLOW CHART

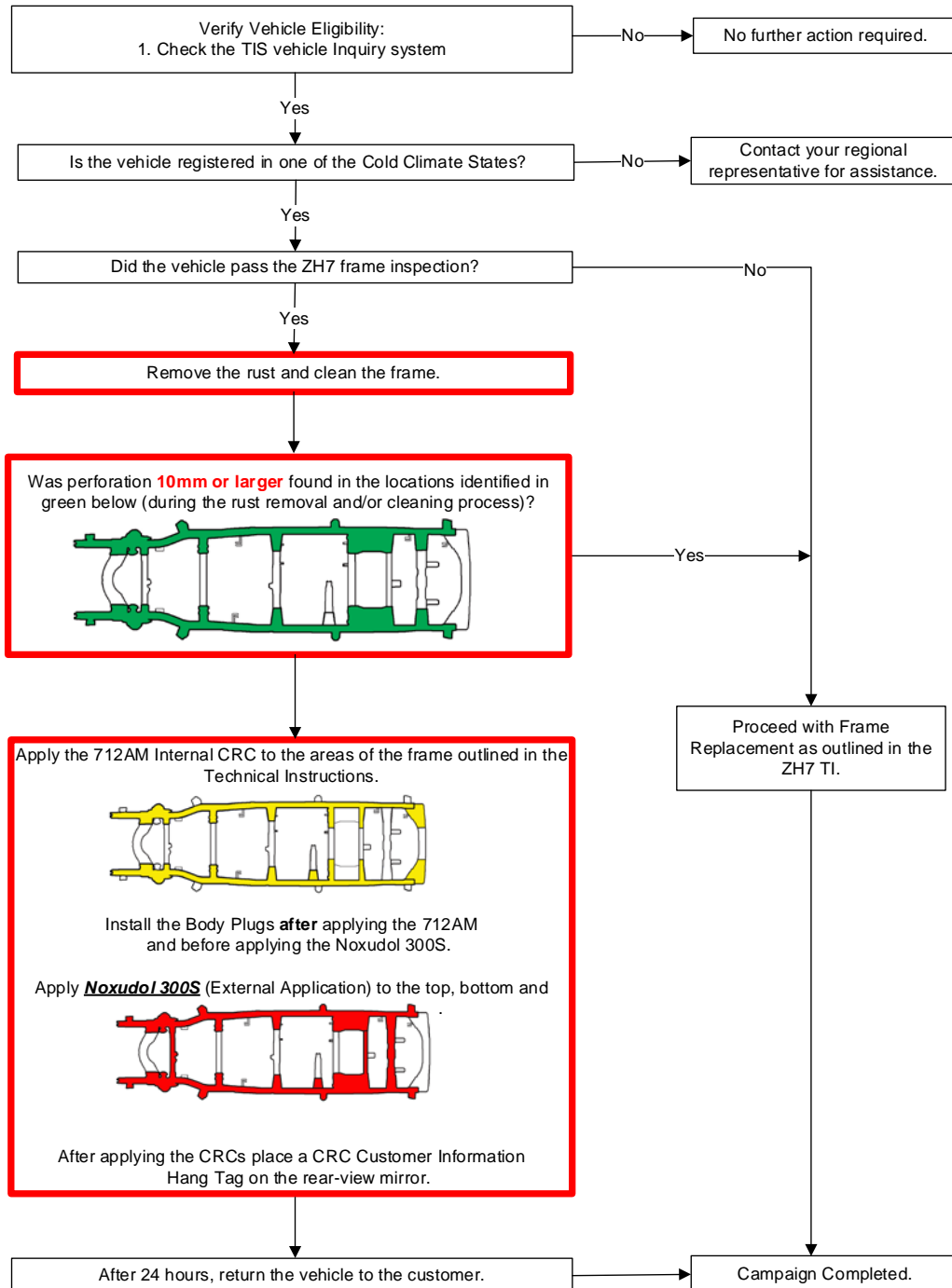

Note: Ensure to follow the entire procedure and perform all steps completely (e.g. inspection, cleaning/rust removal, CRC application, one kit per vehicle, etc.); any deviation will be subject to warranty claim debit.

II. IDENTIFICATION OF COVERED VEHICLES

A. COVERED VIN RANGE

- Vehicles currently registered in the Cold Climate States* or the District of Columbia (D.C.) that do not have significant corrosion found are eligible for Corrosion-Resistant Compound (CRC) application to the frame if it did NOT previously have the frame sprayed and/or had the frame previously replaced.
- Check TIS to confirm the VIN is covered in H0F. This will verify the vehicle is covered and has not already been completed prior to dealer shipment or by another dealer.
- TMS warranty will not reimburse dealers for repairs conducted on vehicles that are not covered or were completed by another dealer.

* CT, DE, IL, IN, KY, MA, MD, ME, MI, MN, NH, NJ, NY, OH, PA, RI, VA, VT, WI, and WV

**Refer to section V. for inspection procedures and criteria

III. PREPARATION

A. PARTS

Please be aware that only dealers in Cold Climate States will be allowed to order the following CRC kit.

The necessary CRC kits can be ordered through the chemical program provided by Dealer Tire (Complete Maintenance Care). The CRC kits will be shipped directly from AMREP. Your dealership should not order kits until you have confirmed an appointment. However, please keep in mind it will take at least 5 business days for CRC kit delivery. Deliveries are only scheduled on business days. Saturday deliveries are not available.

Model	Part No.	Part Description	Qty/Unit
Tundra	00289-T00KT-DS	T00-Corros Res Kit (CRC Kit)	1
<p>The kit above includes the following parts: Noxudol 300S – 3 Liters Parker 712AM – 1 Liter</p>			

1. When Ordering CRC Kits Please Note:

- Each kit will contain the exact amount of CRC for one vehicle.
- The CRC kits listed will be drop-shipped from AMREP, not your local PDC. Do not order more than your immediate needs, as these materials are not returnable or refundable.
- Orders for these parts should be placed separately from orders of other drop ship chemicals.
- Refer to the Appendix for the Safety Data Sheet (SDS).

2. When Storing the CRC Kits Please Note:

- Follow local, state and federal regulations for hazardous materials storage and disposal that are explained in the Hazardous Waste Management Section of the Federal, State and Local Requirements Guide of the Dealer Information Packet.
- Store the CRC kits at room temperature (refer to the SDS for detailed instructions).

B. SUPPORT MATERIALS

- The following support materials can be ordered through the dealer's facing **PDC**:

Part Number	Part Description	Qty
04007-18234	Tundra Plug Kit	1 per vehicle
The kit listed above includes the following parts:		
Part Number	Part Description	Qty
90950-01A24	PLUG,HOLE	2
90950-01987	PLUG,HOLE	8
90950-01990	PLUG,HOLE	3
90950-01994	PLUG,HOLE	6
90950-01993	PLUG,HOLE	8
90950-01988	PLUG,HOLE	2
90950-01A09	PLUG,HOLE	10
90950-01A11	PLUG,HOLE	2
90950-01A06	PLUG,HOLE	2
90950-01986	PLUG,HOLE	2
90950-01826	PLUG,HOLE	2
90480-19374	PLUG,HOLE	1

- The following support materials can be ordered through the dealer's facing **PDC**:

Part Number	Part Description	Qty
04007-23234	Plug Kit	1 per vehicle
The kit listed above includes the following parts:		
Part Number	Part Description	Qty
90950-01A31	PLUG,HOLE	2
90480-A0002	PLUG,HOLE	4

- The following support materials can be ordered through the **MDC**:

Part Number	Part Description	Qty
00411-11004	Corrosion-Resistant Compound Customer Information Hang Tag*	1 per vehicle

* Additional CRC Customer Information Hang Tags can be ordered in packages of 50 through the MDC.

C. STANDARD TOOLS & EQUIPMENT

- Standard hand tools
- Flat chisel
- Scraper
- Wire brush
- Air nozzle
- Infrared thermometer
- Air coupler (quantity 2)

SPECIAL EQUIPMENT

The following equipment was shipped to your dealership prior to the launch of LSC H0F.

Note: Due to federal, state and local regulations, each dealer is only allowed to have one set of spray guns. Any old previous spray guns from previous campaigns should be disposed of in accordance with local regulations.

As a result, each participating dealer will have 2 total spray guns in their possession:

Equipment	Purpose	Application Area
Spray Gun	Noxudol 300S	Exterior Frame CRC Application
Spray Gun	712AM	Interior Frame CRC Application

The items below were previously shipped to your dealership for previous CRC campaigns.

Magnet Kit

- 30 Rare Earth Magnets – See section VI.C.1 “Attach Plastic Sheet” for details.

*Follow the CRC Support link located in the left bottom corner of the C.L.E.A.N DEALER webpage.

D. MATERIALS & SUPPLIES (Locally Procured by Dealer)

- Protective eyewear
- Dust mask
- Appropriate NIOSH approved respirator** (Follow all Federal, State, Local Environmental, Health and Safety Requirements such as OSHA Regulations. Please refer to the SDS for details on the appropriate mask for each CRC.)



Example of a NIOSH-approved respirator

****Notes:**

- Refer to the SDS located in the Appendix for additional information on respirator use.
- It is up to the individual dealership to ensure compliance with OSHA regulations.
- If you require further assistance in regards to NIOSH approved respirators, we have found 3M® to be a useful reference/source.

3M® Technical Assistance: 1-800-243-4630
 3M® Customer Service: 1-800-328-1667
 3M® Web Site: www.3m.com/occsafety

- Protective gloves
- Chemical Resistant Gloves (refer to SDS for specific type)
- Masking tape
- Duct tape
- Fire-retardant poly sheeting (tarp) or covering (if you cannot purchase the tarp from a local supplier, please refer to **CRC Tips and Examples** located on the C.L.E.A.N. DEALER website (<http://cleandealer.com>) for a list of possible suppliers)
- Plastic (Saran Wrap) sheet (for spray gun storage)
- Partitions (The type, size, and number of partitions used will depend on each dealer’s facility.)
- Shop cloth/paper towels
- Funnel (quantity = 2)
- Plastic sheet to contain the dripping 712AM during frame application, 3m x 3m (118in x 118in)
- Garbage Bags

IV. BACKGROUND

Toyota has received a number of reports regarding Frame Corrosion on 2005 – 2010 model year Tacoma vehicles, 2007-2008 Tundra vehicles, and 2005-2008 Sequoia vehicles. In these reports, customers have indicated that vehicles operated in specific cold climate areas with high road salt usage may exhibit more-than-normal corrosion to the vehicle's frame. This condition is unrelated to and separate from normal surface rust which is commonly found on metallic surfaces after some years of usage and/or exposure to the environment.



- Because of variations in state and local laws, dealerships conducting HOF in certain states may require government approvals prior to starting the campaign. Depending upon the state, dealerships also may be subject to restrictions on the number of vehicles to which the CRC can be applied in any single day, week, or month. Please refer to *Dealer Information Packet* and any Supplements for important information about any such approvals or restrictions that may apply to your dealership. Your dealership must adhere strictly to these requirements.
- For a complete list of site selection guidelines, and fire, building, and zoning code information for your state, please refer to the Dealer Information Packet (provided at the time of launch) as well as any Supplements. Please ensure your dealership complies with all regulations and all issued packets and instructions.

V. VEHICLE INSPECTION WORK PROCEDURE

Vehicle frame inspection is performed under WEP ZH7. Reference the Technical Instructions for WEP ZH7 to determine the repair procedure for each vehicle.

VI. FRAME APPLICATION WORK PROCEDURE



- Due to the flash point of the CRC materials, allow sufficient time for the vehicle and exhaust to cool down before beginning the application process. By following the **FRAME APPLICATION WORK PROCEDURE** in these Technical Instructions, the vehicle will have additional time to cool before the CRC's are applied. Please refer to the SDS (Located in the Appendix) for flash point temperatures.

A. WORK AREA SETUP (SUGGESTED)

1. INITIAL SETUP CONSIDERATIONS & GUIDELINES

- a) Work with your Service Manager to locate a dedicated work area and lift with the following requirements.
 - i. In well ventilated area.
 - ii. Away from other vehicles to minimize the possibility of overspray.
 - iii. In a location that can be sectioned off by partitions.
 - iv. In an area that provides sufficient distance from neighboring stalls.
 - v. In an area that meets the minimal space requirements as outlined in Site Selection Guide of the Dealer Information Packet (*provided at the launch of HOF*) and any Supplements.
 - A fire extinguisher, rated "B", "AB" or "ABC", must be located in an area that is within at least 30' of application area.
 - Important Reminder: Because of specific fire and building code requirements, make sure to review the Site Selection Guide of the Dealer Information Packet (*provided at the launch of HOF*) and any Supplements to ensure that the area where you will conduct the CRC application is compliant with the appropriate requirements.

Note: area set up may vary depending on dealership layout. The following information is just one example of how an area might be set up for frame CRC application.

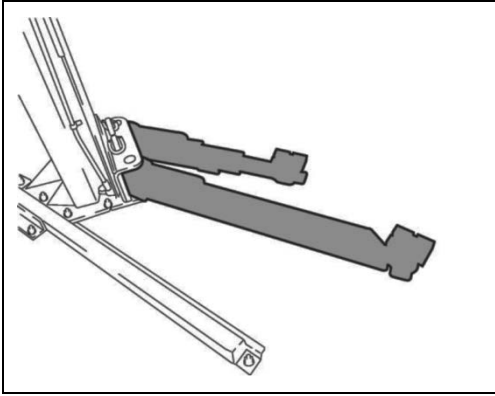

1. MASK THE LIFT SWING ARMS

- a) Cover the lift swing arms with fire-retardant poly sheeting (tarp).
- b) Secure the tarp with masking tape.

Notes:

- A two post above-ground lift is shown for reference purposes.
- Inspect the tarp on a daily basis for damage (cuts, tears, etc.) and replace as necessary.
- Dispose of old tarps in the same manner as other regulated waste at your dealership. Refer to the Dealer Information Packet for more info.

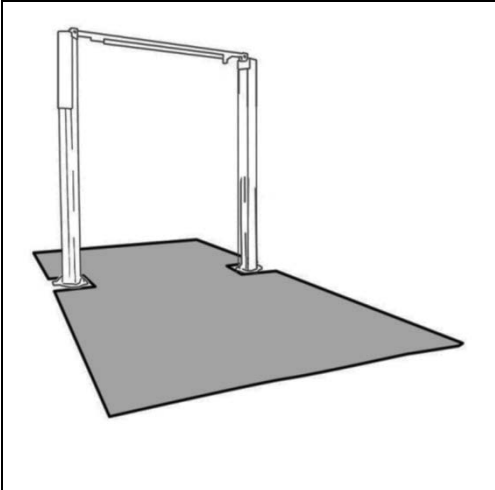

2. WORK AREA SETUP

- a) Cover any exposed section(s) of the lift with fire-retardant poly sheeting (tarp), and secure with masking tape.
- b) Place the fire-retardant tarp(s) as shown in the illustration to protect the floor.

Notes:

- When laying out the tarp on the floor, be sure it is secure and does not create a slipping hazard when walked upon.
- Inspect the tarp on a daily basis for damage (cuts, tears, etc.) and replace as necessary.
- Dispose of old tarps in the same manner as other regulated waste at your dealership. Refer to the Dealer Information Packet for more information.
- A two post above-ground lift is shown for reference purposes.

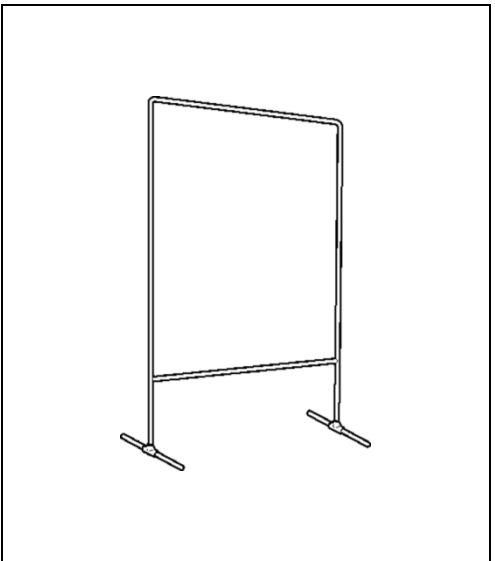

- a) Setup partitions according to the facility needs of your dealership.

Notes:

- The type, size, and number of partitions used will depend on each dealer's facility.
- Set up partitions according to the guidelines established in the Fire, Building, and Zoning Code section of the Dealer Information Packet (provided at the time **XXX** launch) and any Supplements.
- Partitions should minimize any overspray to nearby stalls, while ensuring adequate ventilation.
- Inspect the partition(s) on a daily basis for damage (cuts, tears, etc.) and repair/replace as necessary.
- Dispose of used partitions in the same manner as other regulated waste at your dealership. Refer to the Dealer Information Packet for more information.

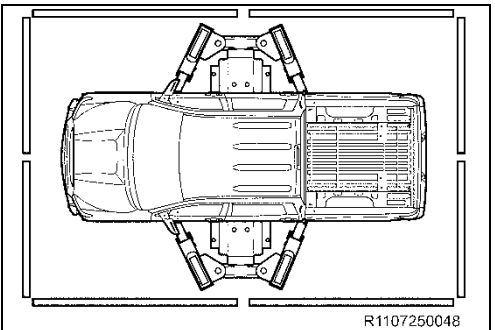

- c) Position the partitions around the vehicle to prevent overspray, as shown in the illustration.

Note: The partitions shown are just an example of what can be used.

R1107250048

B. VEHICLE PREPARATION AND REMOVAL OF FRAME RUST

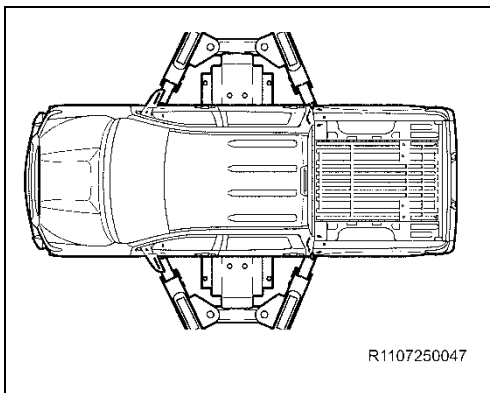

1. PREPARE THE VEHICLE

- a) It may be necessary to pressure wash the vehicle's frame, depending on its cleanliness.

Note: Time has been allotted to pressure wash the frame in the flat rate time.

- b) Place the vehicle on the lift.



Strap the vehicle to the lift with safety straps. Once the vehicle is raised to the desired height, install screw jacks to the front and back of the vehicle.

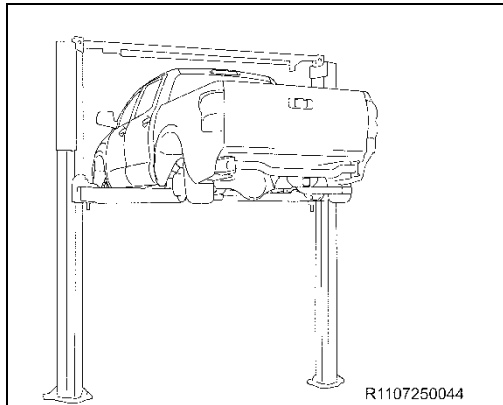

- c) Raise up the vehicle and remove the wheels.
d) Remove the engine under cover.
e) Remove the rear mudguards. **(IF Equipped)**
f) Remove the license plate light assy LH/RH
g) Remove the rear bumper plate. **(With Trailer Hitch)**
h) Remove the rear bumper assy.
i) Cover any identifying label (i.e., VIN label, etc.) on the frame with tape.
j) Cover all exposed electrical connectors with tape to protect from over spray.

2. REMOVE RUST FROM THE FRAME AND CROSS-MEMBERS.

- a) Using a scraper / chisel or any power tools (ex : Air needle scaler), remove loose rust and rust scales from the frame and cross-members shown on the left.
b) If rust perforation of **10mm or larger** and/or component corrosion damage is found in the blue area during the rust removal process proceed to the appropriate campaign for repairs.

Notes:

- Be careful not to damage the wire harness or brake line and fuel line when removing rust.
- Make sure to wear protective eyewear, gloves, and a dust mask when removing rust and cleaning frame.
- Be extremely cautious not to injure your hands.
- DO NOT scratch or remove the identifying labels (i.e., VIN label, etc.) from the frame.

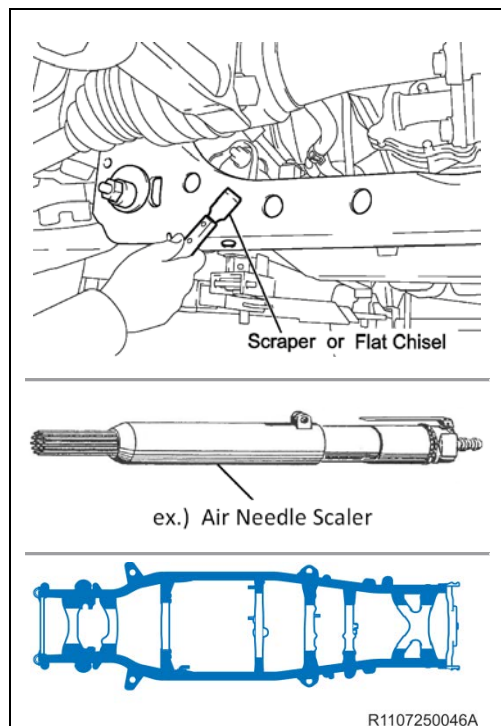

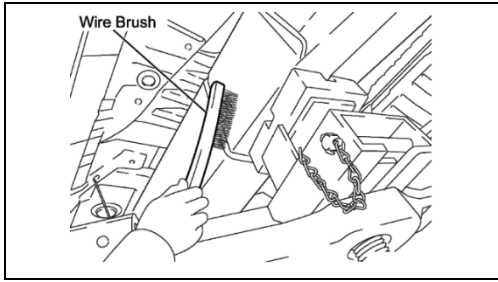

3. CLEAN THE FRAME

- a) Use a wire brush and remove any remaining rust or dirt from the frame.

Ensure to follow the procedure and perform all steps completely (e.g. inspection, cleaning/rust removal, CRC application, one kit per vehicle, etc.) any deviation will be subject to warranty claim debit.

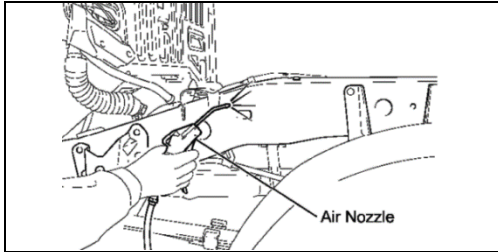

- b) Use an air nozzle and remove any loose rust.

Notes:

- Make sure to wear protective eyewear, gloves, and a dust mask when performing this step.
- A slightly wet frame surface (no water droplets) is acceptable when applying the frame CRC.

Sample of Sufficient Frame Cleaning



Note: A slightly wet frame surface (no water droplets) is acceptable when applying the frame CRC.

C. FINAL FRAME RUST CORROSION PERFORATION INSPECTION

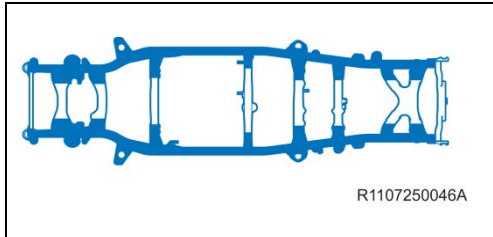

1. VISUALLY INSPECT FOR FRAME PERFORATION AFTER RUST REMOVAL

- a) Visually inspect the specific area highlighted in blue to ensure no perforation was uncovered during the rust removal process
- b) If rust perforation of 10mm or larger is found in the blue areas, proceed to Frame Replacement work procedure.

D. VEHICLE PROTECTION

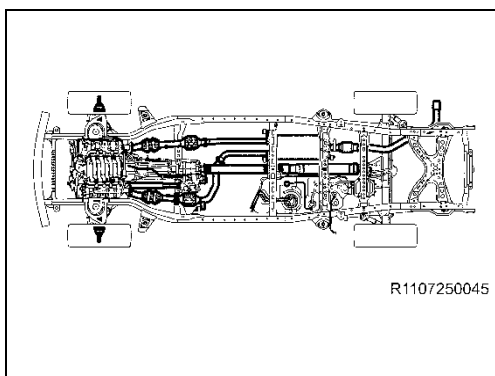

1. ATTACH MASKING MATERIALS

- a) Using an infrared thermometer ensure the exhaust has cooled.
- b) Cover the driveshaft(s) and exhaust, with fire-retardant poly sheeting (tarp) and secure with masking tape.
- c) Cover the front and rear brake/hub assemblies with garbage bags and secure with masking tape.

Notes:

- Cover the air suspension, and shock absorber (if necessary) with masking sheets.
- Overspray onto the driveshaft may cause vehicle vibration.

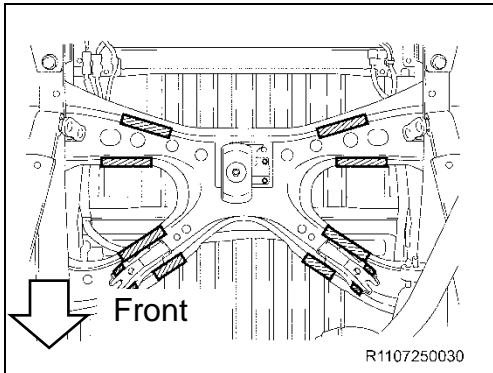

2. COVER SPARE TIRE CONTACT SURFACES ON REAR CROSS-MEMBER

- a) Cover the underside of the rear cross-member with duct tape where the spare tire contacts the rear cross-member.

Notes:

- Tape will prevent Noxudol 300S from sticking to the tire.

E. PREPARE FOR APPLICATION OF CORROSION-RESISTANT COMPOUND (CRC)

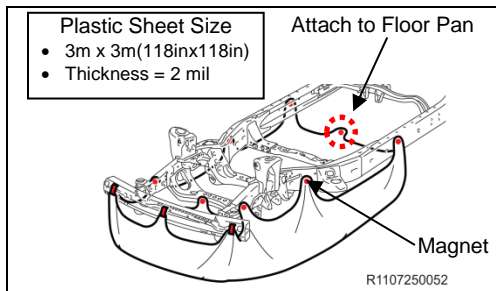

1. ATTACH PLASTIC DRIP SHEET

- a) Before spraying 712AM to the internal frame, fit the plastic sheet on the frame utilizing the supplied magnet kit.

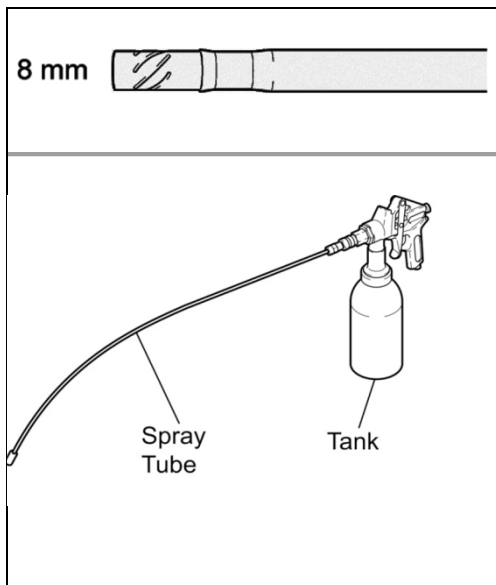

2. SPRAY GUN SET UP FOR 712AM INTERNAL CRC

Notes:

- Use a dedicated spray gun for the 712AM internal CRC and mark/label the gun for 712AM.
- Make sure to wear protective eyewear, impervious gloves (Viton, PVOH, etc.) appropriate Niosh approved respirator, and refer to the MSDS located in the Appendix when handling and spraying CRC.

- a) Check the temperature of the 712AM.

Note: If the 712AM is below 72° F, place the 712AM container in a bucket of hot water (<104° F) for 15 minutes and allow it to warm so the proper viscosity is achieved.

- b) Shake the 712AM container well so that the contents are mixed thoroughly. Settling may occur as it sits over time.
- c) Fill the dedicated tank with 712AM, and attach to the spray gun.
- d) Connect the 8mm spray tube, as shown in the illustration.

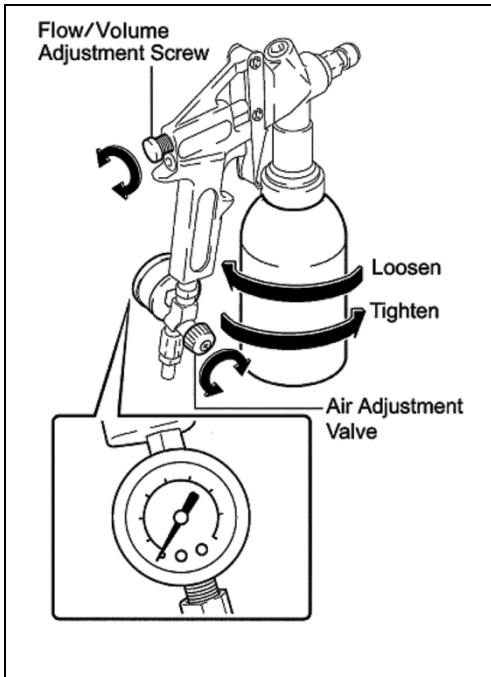

- e) Adjust the spray gun nozzle flow/volume.
 1. Turn the adjustment screw to fully closed position (clockwise).
 2. Then loosen the adjustment screw **4** complete turns.



The air regulator is extremely sensitive; always follow instruction to avoid damage to the gun!

- f) Adjust the air pressure regulator.
 1. Place the nozzle in a clean empty box or pail.
 2. Adjust the air regulator completely closed (No Air Flow)
 3. Attach the air hose to gun.
 4. Fully press the spray gun trigger, and slowly adjust the air pressure to 72.5 psi.

Note: The air regulator has a slight delay and may take up to 10 seconds before the air pressure stabilizes. Move the adjustment knob in very small increments (1/8 turn).

5. Recycle the amount sprayed out and use it during the application process.

F. 712AM INTERNAL FRAME CRC APPLICATION

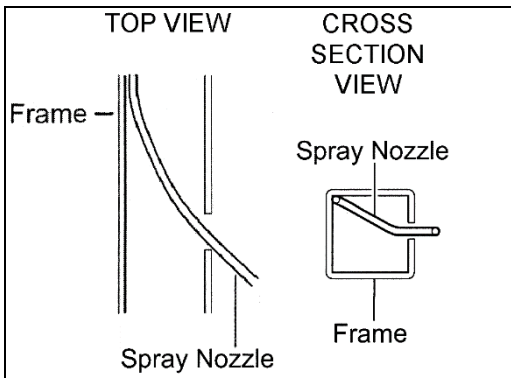

1. 712AM INTERNAL FRAME APPLICATION

- a) Insert the spray nozzle into the selected holes located throughout the frame. Reference the next page for the location, depth, and application rate.
- b) Once the location, depth, and application rate is confirmed, begin applying CRC to the internal frame.
- c) When inserting the nozzle, insert so the nozzle touches the opposite side of the frame as illustrated on the left. See Diagram 1 through 8 for applying CRC.

Note: Make sure the quick coupler on the spray tube does not come into contact with the frame when applying the 712AM. Contacting the frame with the quick coupler may lead to a hose disconnection.

- d) After the 712 AM has been applied, wipe away any wax on the frame's exterior with cloths or paper towels.

Notes:

- Follow all MSDS guidelines for the 712AM which can be found in the Appendix.
- Follow the given application speeds when applying the 712AM to the inner surface of the frame.

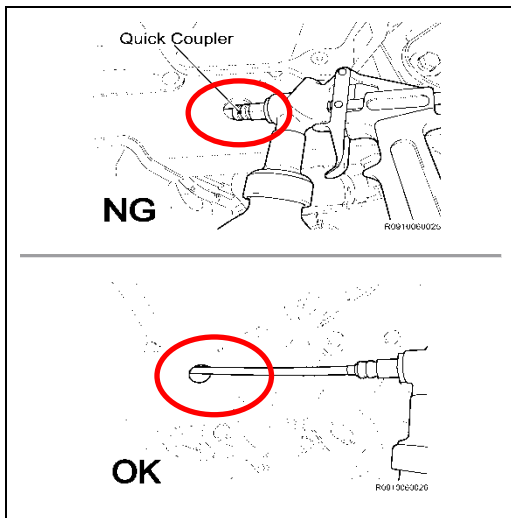
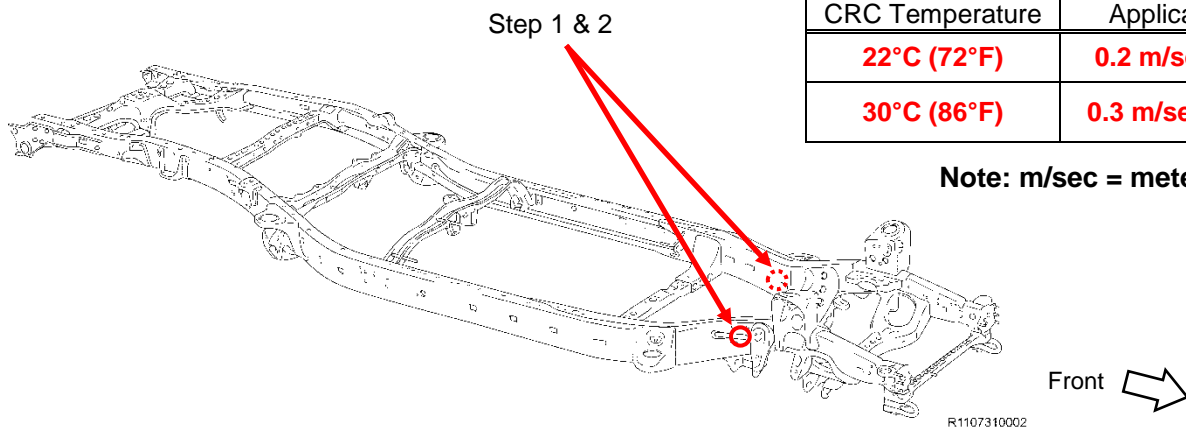

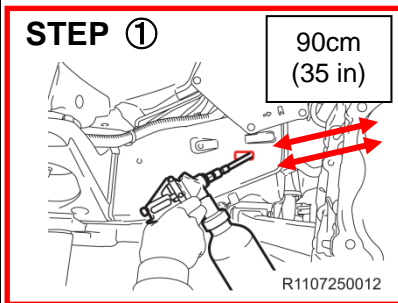

Diagram 1: Internal CRC Application

712AM Internal CRC Application Tube Insert Locations, Depth, and Application Speed



Note: The illustrations of the steps 1 to 2 show application procedure only for the right side of the vehicle. Perform application for the left side of the vehicle in a similar manner.



Step 1 (refer to the table above for application rate):

- While applying the 712AM, insert the nozzle 90cm (35 in) into the side-rail.
- Continue applying the 712AM while removing the nozzle.

Repeat Step 1 for a total of **2 laps**

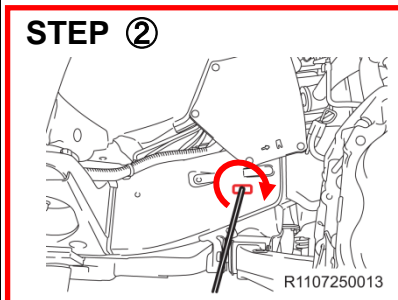

Step 2 (refer to the table above for application rate):

- Insert the nozzle 5 cm (2 in.) towards the front of the frame for **2 seconds**.
- Move the nozzle in a circular motion while applying the 712AM.

Note: Make sure to only insert the nozzle 5cm (2 in) to avoid over spraying onto the engine.

Notes:

- Follow all MSDS guidelines for the 712AM which can be found in the Appendix.
- Only one side is given. Please apply 712AM for opposite side of the frame in similar manner.
- Follow the given application speeds when applying the 712AM to the inner surface of the frame.



Diagram 2: Internal CRC Application

712AM Internal CRC Application
Tube Insert Locations, Depth, and Application Speed



CRC Temperature	Application Speed
22°C (72°F)	0.2 m/sec (8 in/sec)
30°C (86°F)	0.3 m/sec (12 in/sec)

Note: m/sec = meters/second

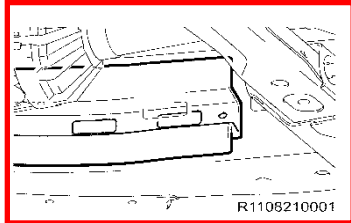

Step 1, 2 & 3

Notes:

- The frame to be applied in the steps 1 and 2 has a **double structure**. Take care not to apply to different cavity.
- Do not insert the nozzle forcibly, otherwise the nozzle may be broken.

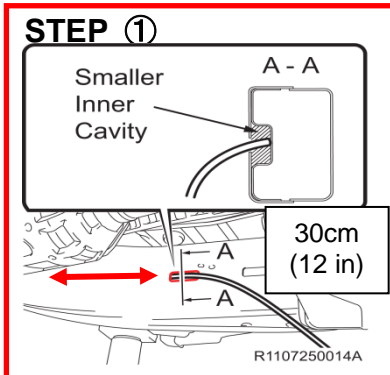

Step 1 (refer to the table above for application rate):

Note: Apply the 712AM **into the smaller inner cavity** as indicated in the illustration.

- While applying the 712AM, insert the nozzle 30cm (12 in) into the side-rail.
- Continue applying the 712AM while removing the nozzle.

Repeat Step 1 for a total of **1 lap**

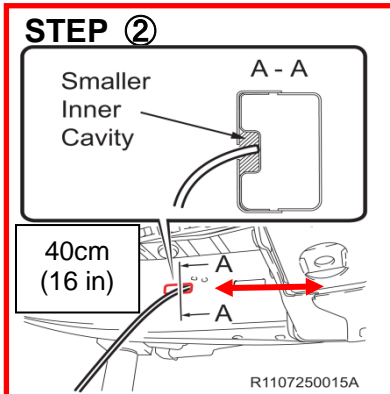

Step 2 (refer to the table above for application rate):

Note: Apply the 712AM **into the smaller inner cavity** as indicated in the illustration.

- While applying the 712AM, insert the nozzle 40cm (16 in) into the side-rail.
- Continue applying the 712AM while removing the nozzle.

Repeat Step 2 for a total of **1 lap**

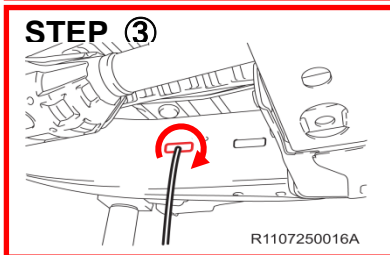

Step 3 (refer to the table above for application rate):

- Insert the nozzle 5 cm (2 in.) towards the front of the frame for **2 seconds**.
- Move the nozzle in a circular motion while applying the 712AM.

Note: Make sure to only insert the nozzle 5cm (2 in) to avoid over spraying onto the engine.

Notes:

- Follow all MSDS guidelines for the 712AM which can be found in the Appendix.
- Only one side is given. Please apply 712AM for opposite side of the frame in similar manner.
- Follow the given application speeds when applying the 712AM to the inner surface of the frame.



Diagram 3: Internal CRC Application

712AM Internal CRC Application
Tube Insert Locations, Depth, and Application Speed

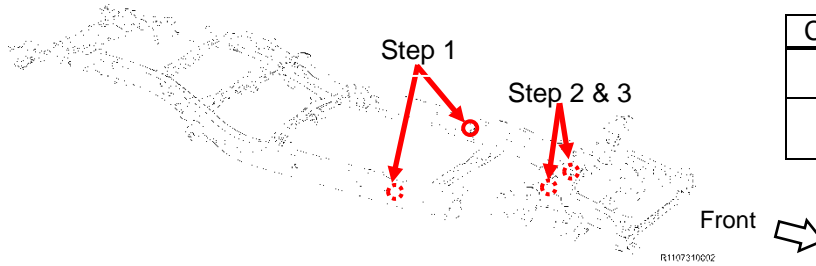

CRC Temperature	Application Speed
22°C (72°F)	0.2 m/sec (8 in/sec)
30°C (86°F)	0.3 m/sec (12 in/sec)

Note: m/sec = meters/second

STEP ①

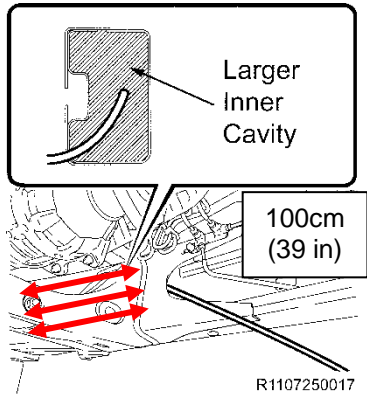

Step 1 (refer to the table above for application rate):

Note: Apply the 712AM into the **larger inner cavity** as indicated in the illustration.

- While applying the 712AM, insert the nozzle 100cm (39 in) into the side-rail. (contact the top center of the frame while inserting nozzle).
- Continue applying the 712AM while removing the nozzle.
- Repeat the step a) to c) two more times (Total: 1 lap)

Repeat Step 1 for a total of **3 laps**

STEP ②

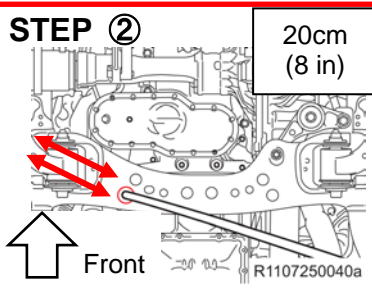

Step 2 (refer to the table above for application rate):

- While applying the 712AM, insert the nozzle 20cm (8 in) into the #2 cross-member.
- Continue applying the 712AM while removing the nozzle.

Repeat Step 2 for a total of **2 laps**

STEP ③

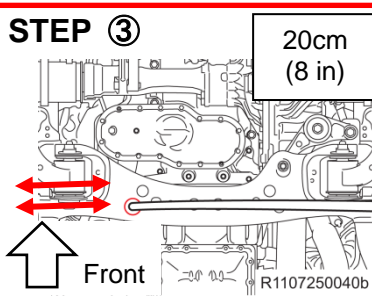

Step 3 (refer to the table above for application rate):

- While applying the 712AM, insert the nozzle 20cm (8 in) into the #2 cross-member.
- Continue applying the 712AM while removing the nozzle.

Repeat Step 3 for a total of **2 laps**

Notes:

- Follow all MSDS guidelines for the 712AM which can be found in the Appendix.
- Only one side is given. Please apply 712AM for opposite side of the frame in similar manner.
- Follow the given application speeds when applying the 712AM to the inner surface of the frame.

Diagram 4: Internal CRC Application



712AM Internal CRC Application Tube Insert Locations, Depth, and Application Speed

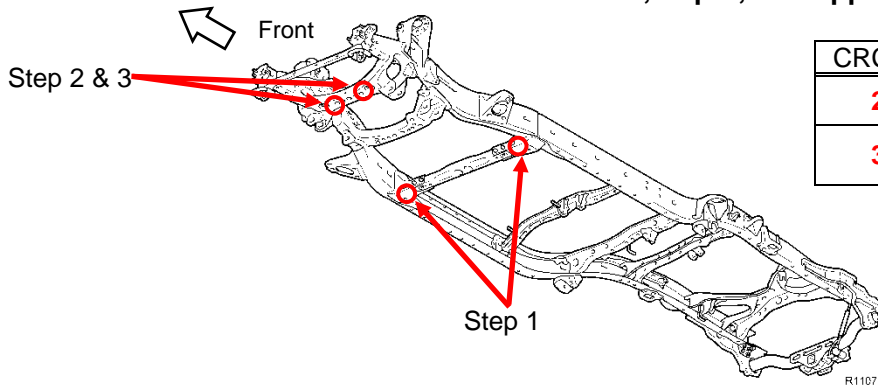

CRC Temperature	Application Speed
22°C (72°F)	0.2 m/sec (8 in/sec)
30°C (86°F)	0.3 m/sec (12 in/sec)

Note: m/sec = meters/second

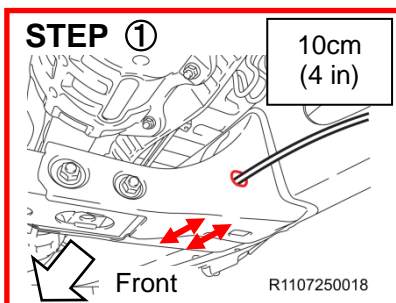

Step 1 (refer to the table above for application rate):

- While applying the 712AM, insert the nozzle 10cm (4 in) into the #3 cross-member.
- Continue applying the 712AM while removing the nozzle.

Repeat Step 1 for a total of **2 laps**

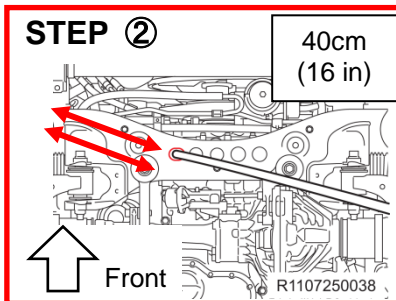

Step 2 (refer to the table above for application rate):

- While applying the 712AM, insert the nozzle 40cm (16 in) into the # 1 cross-member.
- Continue applying the 712AM while removing the nozzle.

Repeat Step 2 for a total of **2 laps**

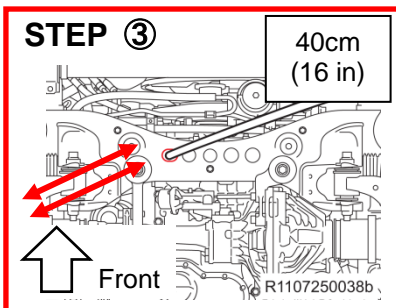

Step 3 (refer to the table above for application rate):

- While applying the 712AM, insert the nozzle 40cm (16 in) into the # 1 cross-member.
- Continue applying the 712AM while removing the nozzle.

Repeat Step 3 for a total of **2 laps**

Notes:

- Follow all MSDS guidelines for the 712AM which can be found in the Appendix.
- Only one side is given. Please apply 712AM for opposite side of the frame in similar manner.
- Follow the given application speeds when applying the 712AM to the inner surface of the frame.

2. LET EXCESS 712AM DRIP

- With a cloth wipe off any drips of 712AM dripping from the frame.
- Before installing the body plugs, confirm that the excess 712AM has stopped dripping from the frame.

3. REMOVE THE PLASTIC DRIP SHEET

G. BODY PLUG INSTALLATION

1. INSTALL THE BODY PLUGS

- The illustrations below show the body plugs installed only on one side of the frame if the installation points are similar for both sides of the frame rails. Be sure to install the plugs on both frame rails even though only one side is shown on the illustrations.
- Install the plugs to prevent dripping and to limit water/road spray from entering the frame rails and cross-members.

KIT 04007-18234

Part Number	Part Description	Qty
90950-01A24	PLUG,HOLE	2
90950-01987	PLUG,HOLE	8
90950-01990	PLUG,HOLE	3
90950-01994	PLUG,HOLE	6
90950-01993	PLUG,HOLE	8
90950-01988	PLUG,HOLE	2
90950-01A09	PLUG,HOLE	10
90950-01A11	PLUG,HOLE	2
90950-01A06	PLUG,HOLE	2
90950-01986	PLUG,HOLE	2
90950-01826	PLUG,HOLE	2
90480-19374	PLUG,HOLE	1

KIT 04007-23234

Part Number	Part Description	Qty
90950-01A31	PLUG,HOLE	2
90480-A0002	PLUG,HOLE	4

RH AND LH ARE SYMMETRICAL. Install plugs on both sides of frame

*1) Only for 'RESIN BUMPER' vehicle. No need for 'STEEL BUMPER' vehicle.

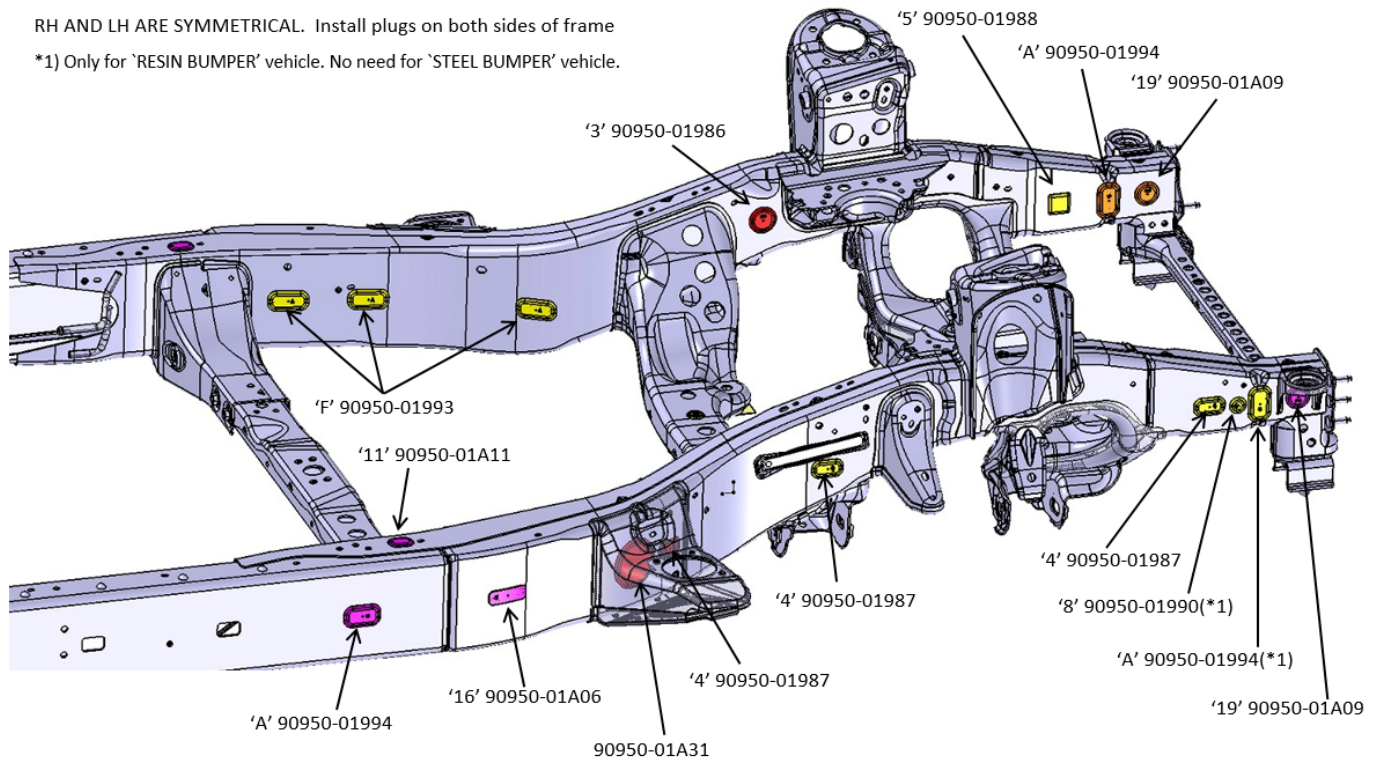

RH AND LH ARE SYMMETRICAL. Install plugs on both sides of frame.

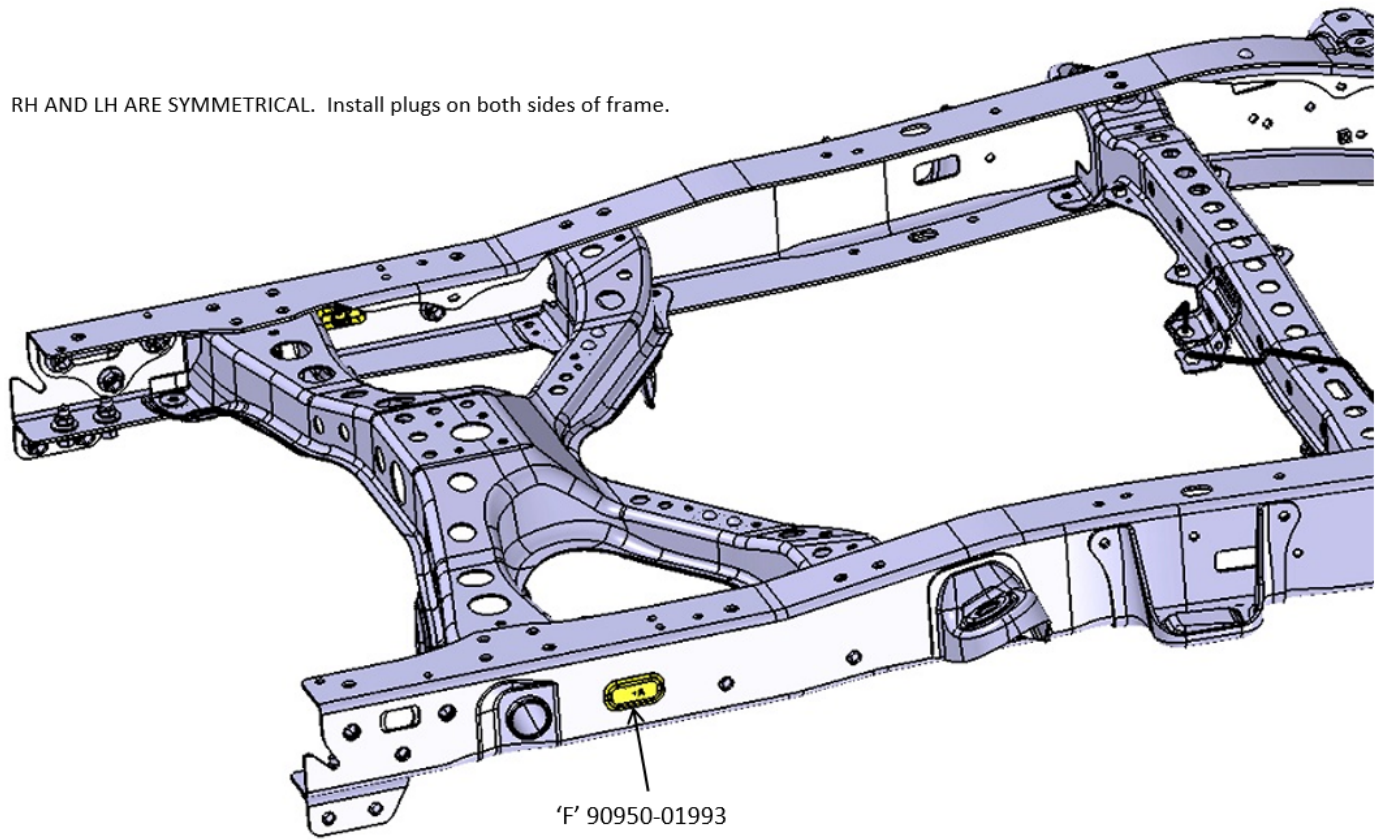

RH AND LH ARE SYMMETRICAL (except as noted). Install plugs on both sides of frame.
*2) Assemble these PLUGS after wax applying.

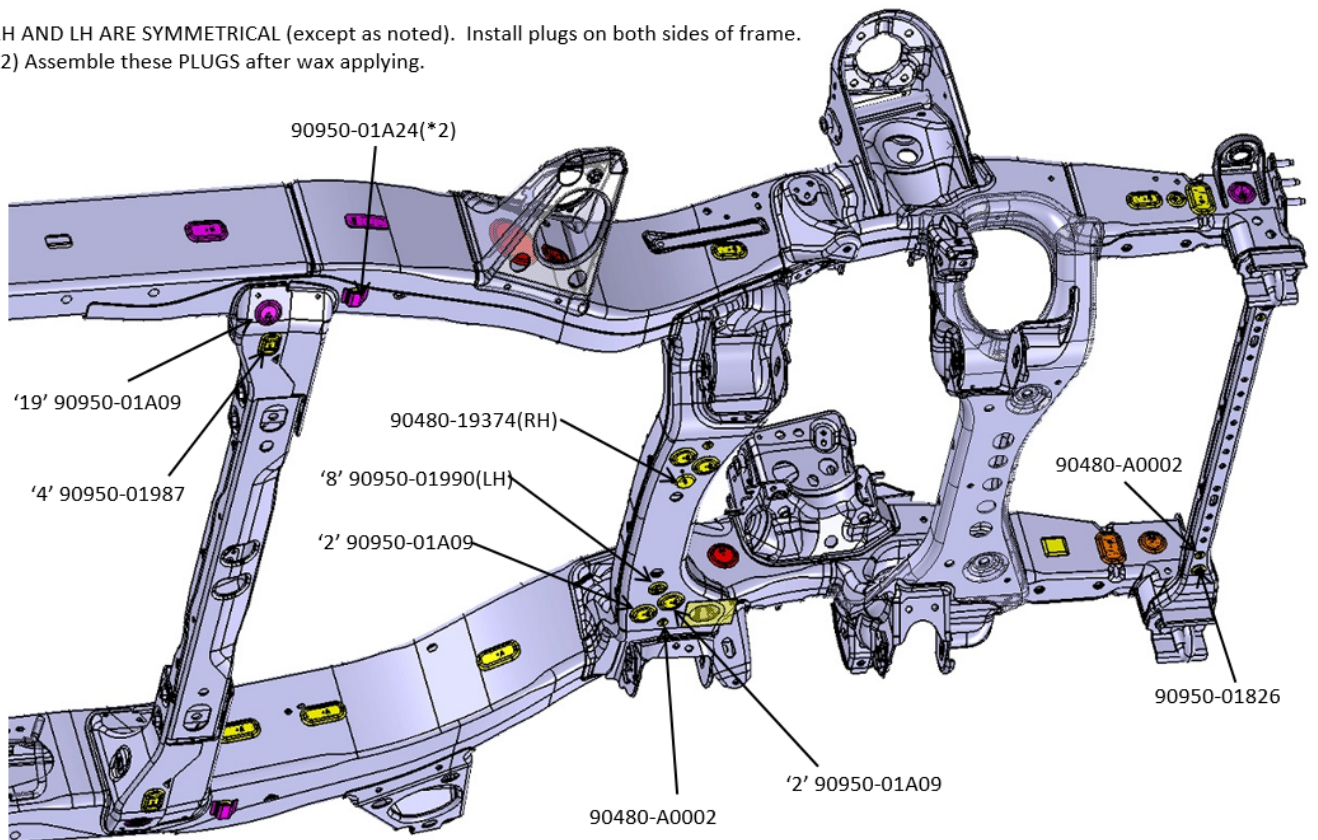

H. PREPARE FOR NOXUDOL 300S EXTERNAL CRC APPLICATION

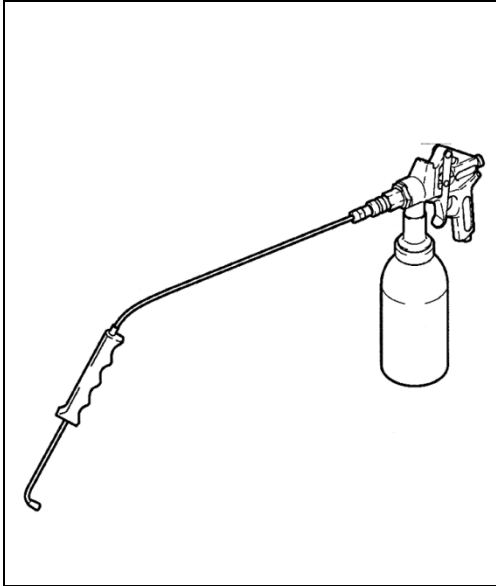

1. SETTING UP THE SPRAY GUN FOR NOXUDOL 300S EXTERNAL FRAME CRC APPLICATION

Notes:

- Use a dedicated spray gun for the NOXUDOL 300S and mark/label the gun for NOXUDOL 300S (external CRC).
- Make sure to wear protective eyewear, chemical resistant gloves, appropriate NIOSH approved respirator, and refer to the MSDS located in the Appendix when handling and spraying CRC.

a) Check the temperature of the Noxudol 300S.

Note: If the Noxudol 300S is below 72° F, place the Noxudol 300S container in a bucket of hot water (<104° F) for 15 minutes and allow it to warm so the proper viscosity is achieved.

b) Shake the Noxudol 300S container well so that the contents are mixed thoroughly. Settling may occur over time.

c) Fill the dedicated tank with Noxudol 300S and attach it to the spray gun.

d) Connect the external spray tube, as shown in the illustration.

e) Adjust the spray gun nozzle flow/volume.

1. Turn the adjustment screw to the fully closed position (clockwise).
2. Then loosen the adjustment screw 3.5 turns.



Caution: Air regulator is extremely sensitive; always follow instruction to avoid damage to the gun!

f) Adjust the air pressure regulator.

1. Place the nozzle in a clean empty box or pail.
2. Completely close the air regulator (No Air Flow).
3. Attach the air hose to the gun.
4. Fully press the spray gun trigger, and slowly adjust the air pressure to 50 psi.

Note: The air regulator has a slight delay and may take up to 10 seconds before the air pressure stabilizes; Move the adjustment knob in very small increments (1/8 turn).

5. Recycle the amount sprayed out and use it during the application process.

g) For Noxudol 300S, it will be necessary to refill the spray gun.

1. Disconnect the air hose.
2. Loosen the bottle to slowly discharge the pressure through the threads of the bottle.
3. After all the pressure is discharged, detach the bottle.

Notes:

- **DO NOT** remove the bottle until the pressure is released.
- **DO NOT** pull the spray gun trigger when the air hose is disconnected, this causes CRC to backflow into the air inlet.
- Thoroughly shake the Noxudol 300S liter before use.
- Apply all three liters of Noxudol 300S to the left and right frames and the cross-members. (No product is allowed to remain.)

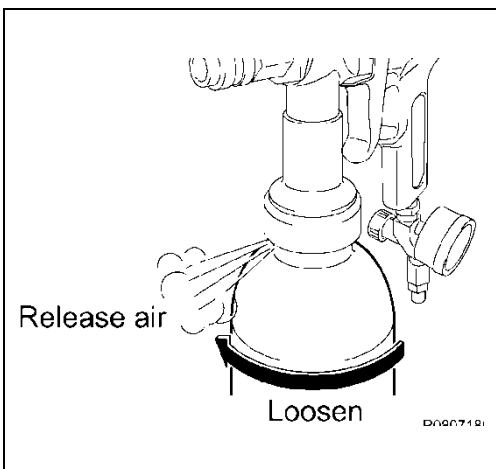
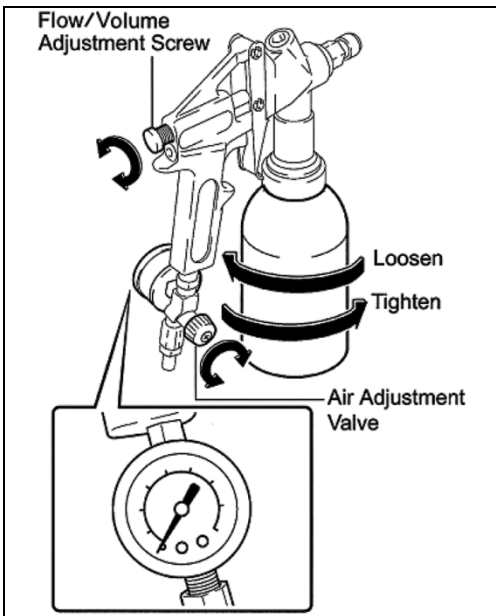

I. UNDER VEHICLE NOXUDOL 300S CRC APPLICATION

1. AFTER REVIEWING THE APPLICATION PROCESS OUTLINED BELOW, BEGIN APPLYING NOXUDOL 300S TO THE REMAINING PORTIONS OF THE EXTERNAL FRAME



- Step ① Coat outer and bottom surfaces of right side frame. (Start from front of the vehicle)
- Step ② Coat inside surfaces of right side frame. (Start from rear of vehicle)
- Step ③ Coat No.0, No.1, No.2, No.3, No.4, No.5, No.6, rear cross-members and receiver hitch bracket sub-assembly from front to back. (Start from front of vehicle)
- Step ④ Coat inside surfaces of left side frame. (Start from rear of vehicle)
- Step ⑤ Coat outer and bottom surfaces of left side frame. (Start from front of vehicle)

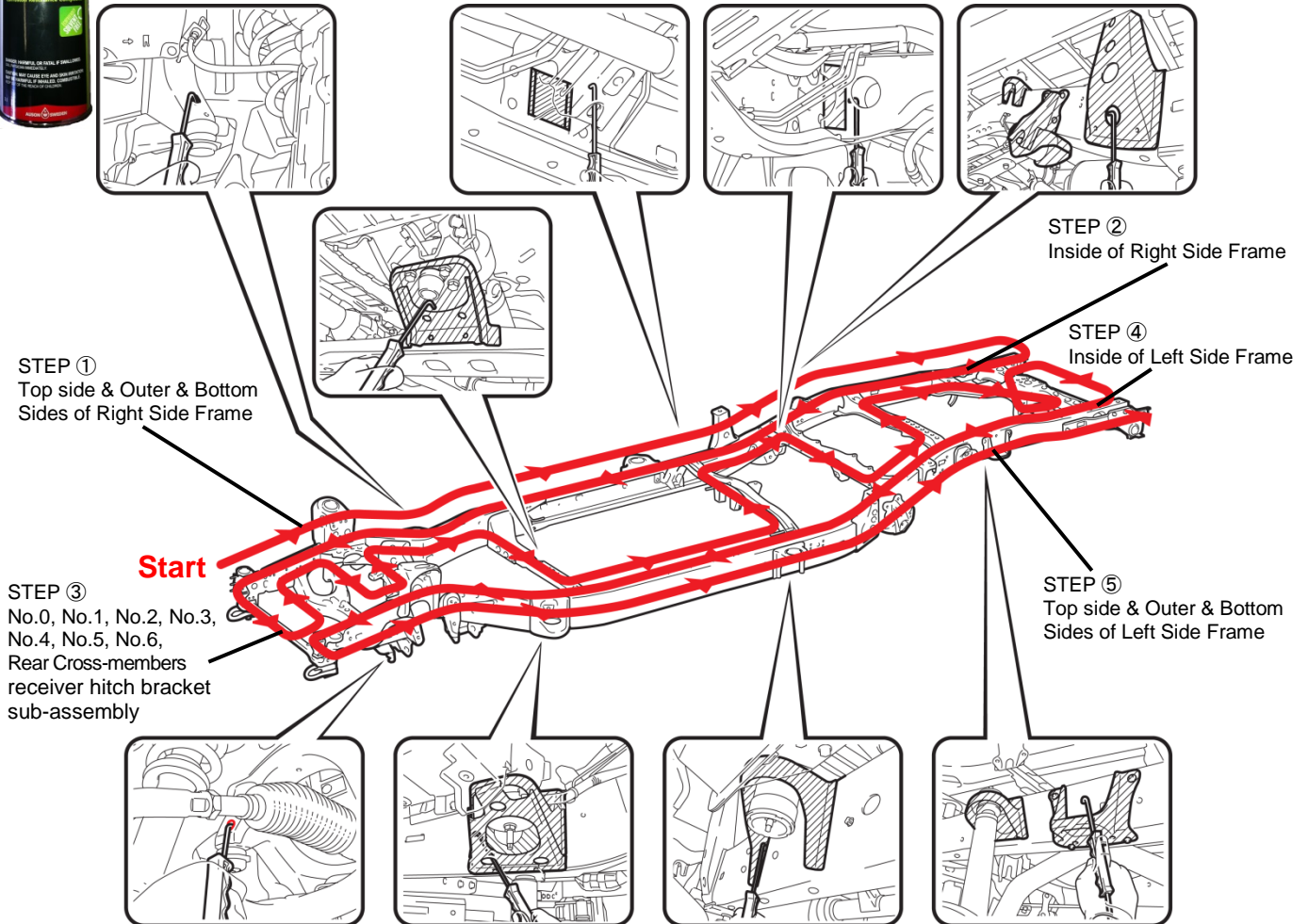

R1107250050C

<p>Position the nozzle 10~20 cm (4 to 8 in.) away from the frame surface. Then apply the Noxudol 300 to the outside frame rail moving the wand at a constant speed of 0.15 m/sec (6 in/sec).</p>	<p>Without stopping, move down and reverse direction as shown in the illustration until the section is completed. Slightly overlap each pass by 5.0cm (2.0 in.) so no gaps appear.</p>	<p>Once the outside surface of the frame rail section you are working on has been completed, without stopping, spray the bottom side as shown in the illustration. Spray the remaining frame and cross-member surfaces in the same manner.</p>	<p>After the entire frame has been completed, inspect and spray any areas that may have been missed.</p>
--	--	--	--

Discharge rate varies depending on CRC temperature. Make adjustments to spray rate as needed, but do not change air pressure (air pressure must be 50 psi).

J. RESTORE THE VEHICLE

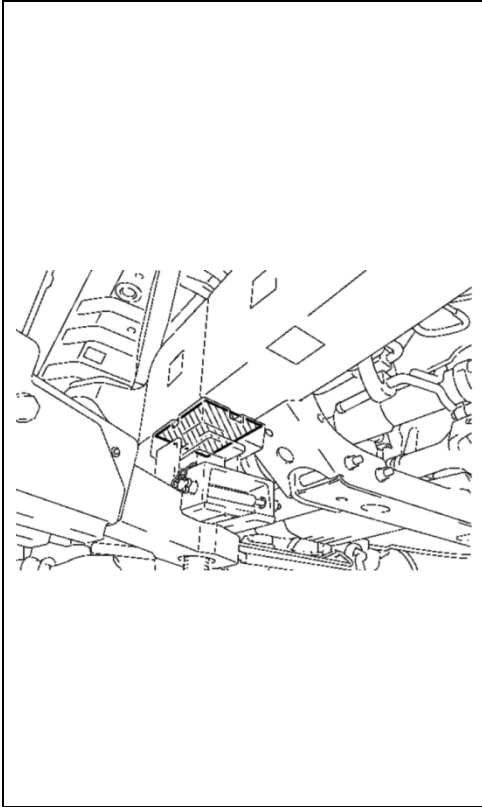

1. RESTORE THE VEHICLE

- a) Re-install the engine undercover.
- b) Re-install wheels and torque to spec.

Aluminum Wheel

Torque Spec: 131 N m (1336 kgf cm, 97 ft lbf)

Steel Wheel

Torque Spec: 209 N m (2131 kgf cm, 154 ft lbf)

- c) Lower the vehicle.
- d) For areas where the lift arms touched, remove any rust present and apply Noxudol 300S.



CONFIRM ALL 3 LITERS OF NOXUDOL 300S HAVE BEEN APPLIED TO THE EXTERNAL PORTION OF THE FRAME!



Ensure to follow the procedure and perform all steps completely (e.g. inspection, cleaning/rust removal, CRC application, one kit per vehicle, etc.) any deviation will be subject to warranty claim debit.

- e) Raise the vehicle.
- f) Remove all masking tape, fire retardant sheeting, and plastic coverings.
- g) Lower the vehicle.
- h) Install the spare tire.
- i) Remove protective tape from the identifying labels (VIN label, etc.) on the frame.
- j) Place a Corrosion-Resistant Compound information Hang Tag on the rear-view mirror.
- k) Let CRC cure approximately 24 hours before returning vehicle to customer.

STORING THE SPRAY GUN (Spray Guns do not require cleaning if they are properly stored)

- a) Spray Gun Storage. (when the spray guns are not in use follow the procedure outlined below)
 - 712AM Internal Frame Application Spray Gun:
 - Remove the air hose from the spray gun.
 - Loosen the spray gun from the canister to release the air pressure. To minimize exposure to the air, once the air pressure is released retighten the spray gun to the canister.
 - Leave the spray tube on the spray gun and place the originally equipped nozzle cap on the tip.
 - NOXUDOL 300S External Frame Application Spray Gun:
 - Remove the air hose from spray gun.
 - Loosen the spray gun from the canister to release the air pressure. To minimize exposure to the air, once the air pressure is released retighten the spray gun to the canister.
 - Leave the spray tube on the spray gun and wrap the tube tip with saran wrap. Seal the saran wrap with a rubber band.

RECORD-KEEPING AND OTHER REQUIREMENTS

To make sure that your dealership can satisfy specific state and local requirements, please refer to your specific state Dealer Information Packet (provided at the time of HOF launch). Critical requirements are described in the Air Regulation, Air Recordkeeping, and Fire, Building, and Zoning Code Sections of the Federal, State and Local Requirements Guide and in the Site selection Guide, all found in the Dealer Information Packet and Supplements.

VII. APPENDIX

A. 712AM & NOXUDOL 300S DISPOSAL

712AM & Noxudol 300S used in the application of the frame CRC as well as any materials, such as tarps with residue, must be disposed of in the same manner as other hazardous waste at your dealership and in accordance with all applicable local, state, and federal regulations. Please refer to the Dealer Information Packet for additional information.

B. REPLACEMENT OF 712AM APPLICATOR NOZZLE

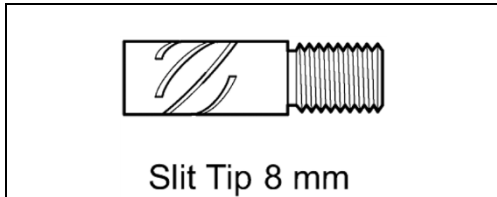

1. NOZZLE REMOVAL AND INSTALLATION

In the event the tip separates from the hose, follow these procedures for repair.

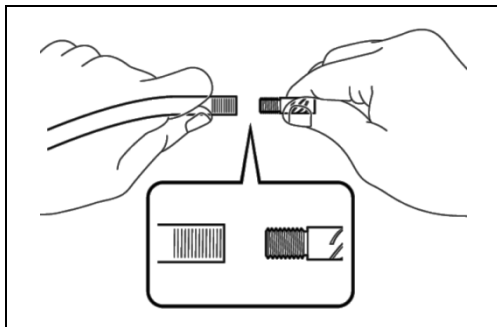

- a) Twist and remove the nozzle from the hose.
- b) Screw the nozzle onto the threaded section of the **NEW** hose at the nozzle connection.

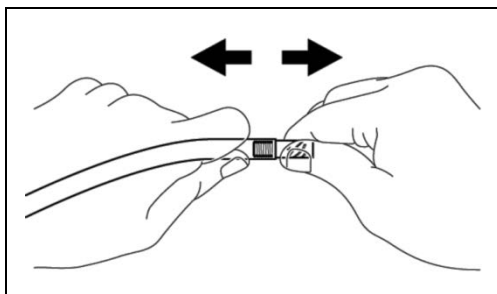

- c) Holding both the nozzle and the hose pull to ensure they are securely attached.

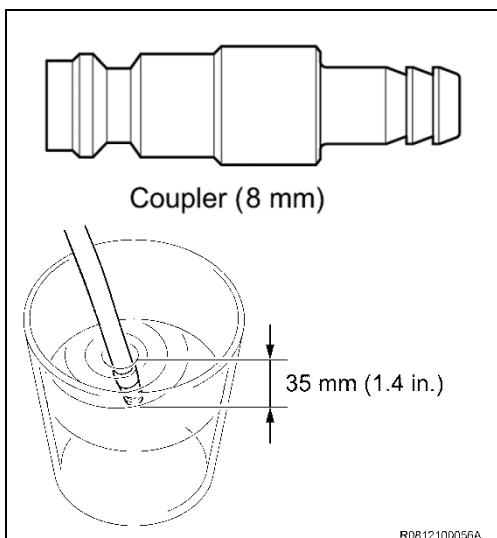

2. COUPLER REMOVAL AND INSTALLATION

- a) Immerse the entire coupler in 70°C (158° F) or hotter water for 10 seconds. This will loosen the coupler and allow it to be removed more easily.



WARNING: Wear insulated gloves, while performing the coupler removal and installation process. The items may be hot.

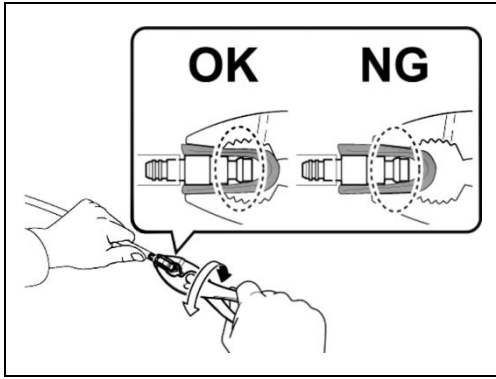

- b) Immediately after removing the coupler from the hot water, twist and pull to separate the coupler from the hose using pliers and a paper towel.

Notes:

- Place the paper towel between the pliers and the coupler to avoid damage.
- Be careful to place the pliers so as to not damage the connection joint for the spray guns.
- The coupler and nozzle hose may be hot.

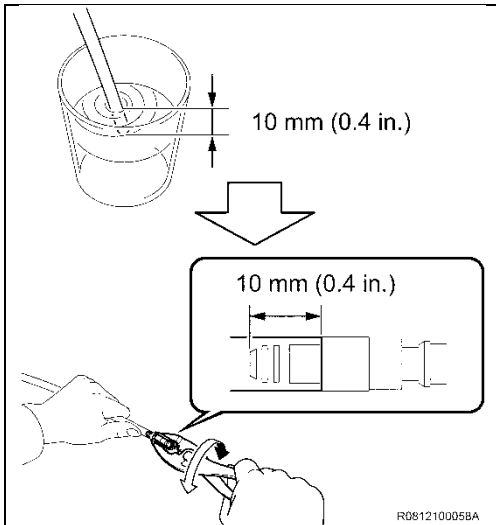

- c) Immerse approximately 10mm (0.4 in.) of the non-threaded section of the **NEW** nozzle hose in 70°C (158°F) or above hot water for 10 seconds.
- d) Immediately after removing the nozzle hose from the hot water, install the coupler to the hose by twisting it.

Notes:

- The coupler should be inserted all the way into the hose to ensure it will not detach.
 - If the hose has cooled and the coupler cannot be inserted, reheat it with hot water.
 - The coupler and hose may be hot.
- e) Once the nozzle hose has cooled to room temperature, hold both the coupler and hose and pull to ensure that they do not separate.

C. REINSTALL THE FOLLOWING PARTS

1. REINSTALL THE FOLLOWING PARTS

- Rear Mudguards (*IF Equipped*)
- Rear Bumper Pad Sub-Assy (*IF Equipped*)
- Rear Bumper Assy
- License Plate Light Assy LH/RH

D. SPRAY GUN TROUBLESHOOTING



1. CONDITION: CRC FLOWS AS LIQUID (NOXUDOL 300S)

Cause: Increasing the air pressure too quickly and having to reduce the regulator pressure.

Background: This condition occurs when the bottle pressure exceeds the regulated air pressure coming into the gun.

Remedy:

- a) Disconnect the Air Hose.
(Do not pull the trigger)
- b) Slowly loosen the bottle to release the air pressure.
- c) Release all air pressure from the tank.
- d) Turn regulator off, completely shut.
- e) Reconnect the air hose.
- f) Fully pull the trigger.
- g) Slowly adjust the regulator to the required air pressure (1/8 turn at a time allowing the, regulator time for the pressure to stabilize.

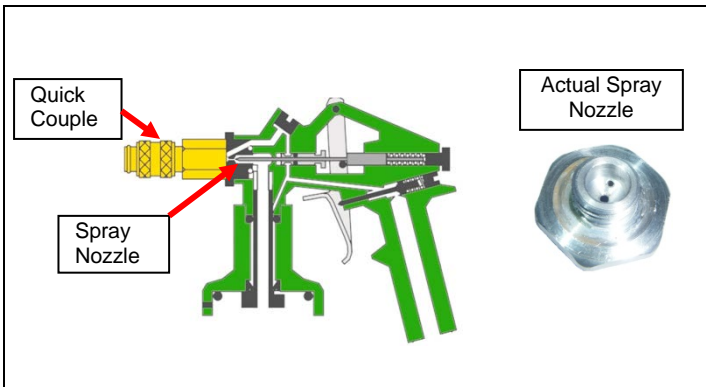

2. IF RESETTING AIR PRESSURE IS NOT SUFFICIENT, CLEAN THE SPRAY NOZZLE WITH SHOP AIR.

- a) Disconnect External Spray Wand.
- b) Remove Quick Coupler. (Brass Color)
- c) Remove Spray Nozzle. (Silver Colored)
- d) Clean Spray Nozzle orfices with shop air.
- e) Reassemble in reverse order.

Note: Ensure not to damage or loose the o-ring that is behind the spray nozzle.

E. SDS Sheets

- Noxudol 300S..... page 24
- 712AM..... page 33



MATERIAL SAFETY DATA SHEET

Noxudol 300 S

Last Updated April 18, 2011

1. CHEMICAL PRODUCT AND COMPANY IDENTIFICATION

Product Name: Noxudol 300 S
Product Codes: None
Product Use: Vehicle Underbody Coating

Synonyms: None
Chemical Name: Anti Rust Compound

Manufacturer: Auson AB
Verkstadsgatan 3
S-434 42 Kungsbacka
Sweden
www.auson.se

US Distributor: Soken Trade Corporation
12055 Sherman Way
North Hollywood, CA
USA

PHONE: +46 300-562000
FAX: +46 300-562001

www.noxudolusa.com
(800) 598-3535
(818) 308-8427

For Chemical Emergency (Spill, Leak, Fire, Exposure, or Accident) Call **CHEMTREC** Day or Night
USA or Canada: 1-800-424-9300 Outside USA or Canada: +1 703-527-3887 (collect calls ok)

PREPARED BY: MSDS Authoring Services
VERSION: 2

ISSUE DATE: April 18, 2011
SUPERSEDES DATE: March 1, 2011

2. COMPOSITION / INFORMATION ON INGREDIENTS

CONTAINING: HAZARDOUS AND/OR REGULATED COMPONENTS

<u>Chemical Name</u>	<u>Amount % by Wt.</u>	<u>CAS Number</u>	<u>OSHA PEL (ppm)</u>	<u>ACGIH STEL (ppm)</u>
Solvent-refined heavy paraffinic distillate	30-60%	64741-88-4	5	None
Petroleum sulfonate, calcium salt, calcium hydroxide and calcium carbonate dispersion	20-30%	68783-96-0	None	None
Fatty acids, tall-oil, polymers with isophthalic acid, pentaerythritol and tall oil	10-20%	68410-37-7	None	None
Paraffin and hydrocarbon waxes	10-20%	8002-74-2	None	2 (fume)
Calcium carbonate (limestone) used as filler/pigment	<2%	1317-65-3	15 for total dust; 5 for respirable fraction	10 for total dust; 3 for respirable fraction
Carbon black	1%	1333-86-4	3.5	3.5
Crystalline silica	<0.1%	14808-60-87	10/(%SiO ₂ +2) (respirable)	2.5

California Prop 65: This product may contain trace quantities of chemicals that are identified by the State of California under the Safe Drinking Water and Toxic Enforcement Act of 1986 ("Proposition 65") as either a carcinogenic or reproductive hazard.

HAZARDS DISCLOSURE: This product contains known hazardous materials in reportable levels as defined by the OSHA Hazard Communication Standard 29 CFR 1910.1200 except as listed above. As defined under SARA 311 and 312, this product contains known hazardous materials.



3. HAZARDS IDENTIFICATION

**EMERGENCY OVERVIEW:
CAUTION! COMBUSTIBLE LIQUID.**

HMIS/NFPA Rating: See Section 16

POTENTIAL HEALTH EFFECTS

ROUTES OF ENTRY: Skin contact, eye contact, inhalation and ingestion.

INHALATION: High vapor concentrations may cause headache, dizziness, fatigue, nausea, and vomiting.

INGESTION: May cause abdominal pain, nausea, and vomiting.

SKIN CONTACT: Contact may be irritating to skin. May defat skin.

EYE CONTACT: Contact may be irritating to eyes. May cause stinging.

CHRONIC EXPOSURE: There are currently no known adverse health effects associated with chronic exposure to this product.

ACUTE HEALTH HAZARDS: Moderately irritating to the skin. Slightly irritating to the eyes. May be harmful if inhaled.

AGGRAVATION OF PRE-EXISTING CONDITIONS: Persons with pre-existing skin disorders, eye problems, or respiratory function may be more susceptible to the effects of this substance.

TARGET ORGANS: Eyes, skin, and respiratory system.

CARCINOGENICITY:

OSHA: Not listed ACGIH: Not listed NTP: Not listed IARC: Not listed

POTENTIAL ENVIRONMENTAL EFFECTS: Not considered to be harmful to aquatic life.

4. EMERGENCY AND FIRST AID PROCEDURES

INHALATION FIRST AID: If inhalation is experienced or suspected, move exposed person to fresh air. If not breathing, give artificial respiration. If breathing is difficult, give oxygen. Get medical attention immediately if symptoms persist.

SKIN CONTACT FIRST AID: In case of contact, immediately flush skin with soap and water. Remove contaminated clothing and shoes. Wash clothing before reuse. Call a physician if irritation develops.

EYE CONTACT FIRST AID: Immediately flush eyes with plenty of water for at least 15 minutes, lifting lower and upper eyelids occasionally. Get medical attention immediately if symptoms persist.

INGESTION FIRST AID: If swallowed, give a few tablespoons of cooking oil, sour cream, cream, or other liquid fat. Contact the poison control center. DO NOT INDUCE VOMITING unless directed to by a poison control center or physician. Never give anything by mouth to an unconscious person.

STATEMENT OF PRACTICAL TREATMENT: Always have plenty of water available for first aid. Get medical attention if any symptoms develop or persist.

NOTES TO PHYSICIANS OR FIRST AID PROVIDERS: This product has low oral, dermal, and inhalation toxicity. Aspiration during swallowing or vomiting may severely damage the lungs.



5. FIRE AND EXPLOSION HAZARD DATA

FLAMMABLE PROPERTIES: Not flammable. Combustible.

AUTO IGNITION TEMPERATURE (ASTM E659):

HOT-FLAME AUTOIGNITION TEMPERATURE (AIT):

MINIMUM IGNITION TEMPERATURE: 750°F

IGNITION DELAY: 12 Seconds

BAROMETRIC PRESSURE, TORR: 766

COOL-FLAME AUTOIGNITION TEMPERATURE (CFT):

MINIMUM IGNITION TEMPERATURE: 745°F

IGNITION DELAY: 120 Seconds

BAROMETRIC PRESSURE, TORR: 766

REACTION THRESHOLD TEMPERATURE FOR PRE-FLAME (RTT):

MINIMUM REACTION TEMPERATURE: 740°F

LIMITS OF FLAMMABILITY IN GENERAL ACCORDANCE WITH ASTM E-681 AT 200°C

LOWER FLAMMABLE LIMIT (LFL): 1.81 %

UPPER FLAMMABLE LIMIT (UFL): See Note

Note: Due to the nature of the sample and its addition into the test apparatus, it is difficult to determine the upper flammable limit.

FLASH POINT: 140°C 285°F Method Used: ASTM D93

EXTINGUISHING MEDIA: Dry chemical, foam or carbon dioxide.

UNSUITABLE EXTINGUISHING MEDIA: Water spray may be unsuitable.

FIRE & EXPLOSION HAZARDS: Above flash point, vapor-air mixtures are explosive within flammable limits noted above. Containers may explode when involved in a fire.

PRECAUTIONS FOR FIREFIGHTERS: In the event of a fire, wear full protective clothing and NIOSH-approved self-contained breathing apparatus with full face piece operated in the pressure demand or other positive pressure mode. Toxic gases and vapors may be released if involved in a fire.

UNUSUAL FIRE AND EXPLOSION HAZARDS: Not applicable

HAZARDOUS DECOMPOSITION OR COMBUSTION PRODUCTS: Not available.

6. ACCIDENTAL RELEASE MEASURES

ACCIDENTAL RELEASE MEASURES: Remove all sources of ignition.

PERSONAL PRECAUTIONS: Wear appropriate protective clothing (see SECTION 8). Isolate release area and deny entry to unnecessary and unprotected personnel.

ENVIRONMENTAL PRECAUTIONS: Do not allow spill to enter sewers or waterways. Do not flush to sewer.

METHODS FOR CONTAINMENT: Contain spill with sand or earth. Do not use combustible materials, such as sawdust.

METHODS FOR CLEAN-UP: Collect spilled material and non-combustible absorbent and place in a container for disposal. Clean spill area thoroughly.

OTHER INFORMATION: Report spills to authorities as required.

7. HANDLING AND STORAGE



MATERIAL SAFETY DATA SHEET

Noxudol 300 S

Last Updated April 18, 2011

RECOMMENDED STORAGE CONDITIONS: Keep in a tightly closed original container, at temperatures less than 105°F (40°C). Keep containers closed when not in use.

SHELF LIFE: See label on packaging.

HANDLING (PERSONNEL): Wear appropriate personal protective equipment (see SECTION 8). Avoid contact with eyes. Avoid contact with skin or clothing. Avoid breathing vapors. Use only with adequate ventilation. Wash thoroughly with soap and water after handling. Keep away from heat, flames, and sparks.

8. EXPOSURE CONTROLS / PERSONAL PROTECTION

AIRBORNE EXPOSURE LIMITS: See Section 2 above.

CAS NO.	CHEMICAL NAME
64741-88-4	Solvent-refined heavy paraffinic distillate mg/m ³
OSHA PEL-TWA:	5
OSHA PEL STEL:	none
OSHA PEL CEILING:	none
ACGIH TLV-TWA:	5
ACGIH TLV STEL:	none
ACGIH TLV CEILING:	none
68783-96-0	PETROLEUM SULFONATE, CALCIUM SALT, CALCIUM HYDROXIDE AND CALCIUM CARBONATE DISPERSION MG/M ³
OSHA PEL-TWA:	NONE
OSHA PEL STEL:	NONE
OSHA PEL CEILING:	NONE
ACGIH TLV-TWA:	NONE
ACGIH TLV STEL:	NONE
ACGIH TLV CEILING:	NONE
68410-37-7	FATTY ACIDS, TALL-OIL, POLYMERS WITH ISOPHTHALIC ACID, PENTAERYTHRITOL AND TALL OIL MG/M ³
OSHA PEL-TWA:	NONE
OSHA PEL STEL:	NONE
OSHA PEL CEILING:	NONE
ACGIH TLV-TWA:	NONE
ACGIH TLV STEL:	NONE
ACGIH TLV CEILING:	NONE
8002-74-2	PARAFFIN AND HYDROCARBON WAXES MG/M ³
OSHA PEL-TWA:	NONE
OSHA PEL STEL:	NONE
OSHA PEL CEILING:	NONE
ACGIH TLV-TWA:	2 (FUME)
ACGIH TLV STEL:	NONE
ACGIH TLV CEILING:	NONE

CALIFORNIA PROPOSITION 65: This product may contain trace quantities of chemicals that are identified by



MATERIAL SAFETY DATA SHEET

Noxudol 300 S

Last Updated April 18, 2011

the state of California under the Safe Drinking Water and Toxic Enforcement Act of 1986 ("Proposition 65") as either a carcinogenic or reproductive hazard:

1317-65-3 CALCIUM CARBONATE (LIMESTONE)
MG/M3
OSHA PEL-TWA: 15 FOR TOTAL DUST; 5 FOR RESPIRABLE FRACTION
OSHA PEL STEL: NONE
OSHA PEL CEILING: NONE
ACGIH TLV-TWA: 0 FOR TOTAL DUST; 3 FOR RESPIRABLE FRACTION
ACGIH TLV STEL: NONE
ACGIH TLV CEILING: NONE

1333-86-4 CARBON BLACK
MG/M3

OSHA PEL-TWA: 3.5
OSHA PEL STEL: NONE
OSHA PEL CEILING: NONE
ACGIH TLV-TWA: 3.5
ACGIH TLV STEL: NONE
ACGIH TLV CEILING: NONE

14808-60-7 CRYSTALLINE SILICA
MG/M3

OSHA PEL-TWA: 10/(%SIO2+2) (RESPIRABLE)
OSHA PEL STEL: NONE
OSHA PEL CEILING: NONE
ACGIH TLV-TWA: 0.025 (RESPIRABLE)
ACGIH TLV STEL: NONE
ACGIH TLV CEILING: NONE

(Crystalline Silica and carbon black only present hazards as respirable particles of 10 microns or less. Both are bound in the coating and will not be released as respirable particles)

VENTILATION SYSTEM: A system of local and/or general exhaust is recommended to keep employee exposures below the airborne exposure limits. Local exhaust ventilation is generally preferred because it can control the emissions of the contaminant at its source, preventing dispersion of it into the general work area. Please refer to the ACGIH document, *Industrial Ventilation, A Manual of Recommended Practices*, most recent edition, for details.

PERSONAL RESPIRATORS (NIOSH APPROVED): If respirator use is desired, or if exposure limit values are exceeded, use NIOSH approved respirator and type A filters (brown, organic substances).

SKIN PROTECTION: Avoid prolonged skin contact. Chemical resistant (nitrile) gloves recommended for operations where skin contact is likely. Wear appropriate protective clothing or boots as needed. Workers should wash exposed skin several times daily with soap and water. Soiled work clothing should be laundered or dry-cleaned.

EYE PROTECTION: Safety glasses, chemical type goggles, or face shield recommended to prevent eye contact.

GENERAL HYGIENIC PRACTICES: Wash thoroughly with soap and water after handling, before eating, drinking, smoking, or using toilet facilities. Do not smoke during use.



MATERIAL SAFETY DATA SHEET

Noxudol 300 S

Last Updated April 18, 2011

9. PHYSICAL/CHEMICAL CHARACTERISTICS

FORM: Highly viscous liquid
ODOR: Slight mineral oil like odor
SOLUBILITY IN WATER: Not soluble in water
EVAPORATION RATE: (BuAc=1): Not applicable
AUTOIGNITION TEMPERATURE: >750°F 399°C
pH: Not available
VISCOSITY: 500-650 Mpas - 73.4°F (23°C)
VOLATILE ORGANIC COMPOUNDS (VOC): 10.7 g/L using EPA Method 24
COLD FREEZE POINT (ASTM D97): +25
FREEZING POINT (ASTM D1177): This sample was too viscous to permit determination of its freeze point by ASTM 1177.
VAPOR PRESSURE By Isoteniscope (ASTM D2879), torr:
32°F.....0.28
68°F.....1.0
100°F.....2.7
150°F.....11
200°F.....34
250°F.....90
300°F.....160
350°F.....270
400°F.....426
450°F.....600
485°F.....760
COLOR: Black
BOILING POINT: >390°F (>200°C)
SPECIFIC GRAVITY: .96 at 20°C (68°F) (Water =1)
POUR POINT (ASTM) D97): +30
FLASH POINT: 285°F (140°C) ASTM D93
PERCENT SOLIDS BY WEIGHT: 98.9%

10. STABILITY AND REACTIVITY

STABILITY: Stable under ordinary conditions (70°F (21°C) and 14.7 psig (760 mmHg)), of use and storage.
CONDITIONS TO AVOID: Combustible atmospheres. Heat, flames, ignition sources, water (absorbs readily) and incompatibles.
POLYMERIZATION: Not available.
INCOMPATIBILITY WITH OTHER MATERIALS: Do not store near other combustible materials.
DECOMPOSITION: Not available.

11. TOXICOLOGICAL INFORMATION

EFFECTS OF EXPOSURE
ACUTE INHALATION: LC50 not available
EYES: Irritant
SKIN: Irritant
ACUTE INGESTION: LD50 not available



MATERIAL SAFETY DATA SHEET

Noxudol 300 S

Last Updated April 18, 2011

CHRONIC EFFECTS/CARCINOGENICITY: Calcium carbonate, the product itself, is not listed by NTP, IARC, or OSHA as a carcinogen. There is no reported health effects associated with prolonged exposure to pure calcium carbonate. This product contains variable quantities of crystalline silica (quartz), which is considered a hazard by inhalation. IARC has classified crystalline silica as probably carcinogenic for humans (2A). This classification is based on the findings of laboratory animal studies that were considered to provide sufficient evidence and data from human epidemiological studies that were considered to provide limited evidence for carcinogenicity.

Crystalline silica is also a known cause of silicosis, a noncancerous lung disease. NTP and OSHA have not classified crystalline silica as a carcinogen.

Carbon black has been classified by IRAC as a Category 2B (known animal carcinogen, possible human carcinogen) material. This was based on the results of rat inhalation studies of carbon black, despite the lack of parallel evidence on humans or other animal species

MUTAGENIC OR REPRODUCTIVE/DEVELOPMENTAL EFFECTS: None expected.

12. ECOLOGICAL INFORMATION

ECOTOXICITY: This product is not toxic or harmful to the environment.

PERSISTENCE AND DEGRADABILITY: This product is not readily degradable.

MOBILITY: Highly viscous liquid is not water soluble and is not expected to be mobile.

BIOACCUMULATION: This product is not expected to bioaccumulate.

13. DISPOSAL DATA

WASTE DISPOSAL METHOD: It is the responsibility of the generator to determine at the time of disposal the proper classification and method of disposal. Disposal should be in accordance with applicable federal, state, and local regulations. Local regulations may be more stringent than regional or national requirements.

RCRA INFORMATION: If this material as supplied becomes a waste, it does not meet the criteria of a hazardous waste as defined under the Resource Conservation and Recovery Act (RCRA) 40 CFR 261.

CONTAMINATED MATERIALS: Wash contaminated clothing before reuse.

14. TRANSPORTATION DATA

Domestic (Land, D.O.T.), International (Water, I.M.O.), International (Air, I.C.A.O.)

CLASS:	None
PRODUCT LABEL:	Noxudol 300 S
UN NUMBER:	None
PACKING GROUP:	None
D.O.T. SHIPPING NAME:	Consumer Commodity, ORM-D
PRODUCT RQ (LBS):	None
ERG Guide Number:	None
SUPPLEMENTAL HAZARD:	None
VESSEL STOWAGE LOCATION:	None
SHIPPING RESTRICTIONS:	None



15. REGULATORY INFORMATION

U.S. FEDERAL REGULATORY STATUS

TSCA (TOXIC SUBSTANCE CONTROL ACT): All of the components of this product are listed on the TSCA inventory.

CERCLA (COMPREHENSIVE RESPONSE, COMPENSATION, AND LIABILITY ACT): This product is NOT subject to CERCLA environmental reporting requirements; however, many states have more stringent release reporting requirements. Report spills as required under federal, state and local regulations.

SARA TITLE III (SUPERFUND AMENDMENTS AND REAUTHORIZATION ACT): This product does not contain any chemicals subject to SARA Title III. 311/312 HAZARD CATEGORIES: Slight Health Hazard, Slight Flammability Hazard

CAA (CLEAN AIR ACT): This product conforms to the VOC limits listed under Subpart B: National Volatile Organic Compound Emission Standards for Automobile Refinish Coatings under Section 183(e)(3)(C).

OTC (OZONE TRANSPORT COMMISSION): This product conforms to the VOC limits listed in Model Rule 2009 – Motor Vehicle and Mobile Equipment Non-Assembly Line Coating Operations.

STATE REGULATIONS:

California Safe Drinking Water and Toxic Enforcement Act (Proposition 65): This product is known to contain chemicals currently listed as carcinogens or reproductive toxins as regulated under California Proposition 65.

California Air Resource Board (CARB) Suggested Control Measure for Automotive Coatings: This product conforms to the VOC limit for the automotive undercoating.

LOCAL REGULATIONS

SCAQMD (SOUTH COAST AIR QUALITY MANAGEMENT DISTRICT) RULE 1151: This product conforms to the VOC limits listed under Rule 1151—Motor Vehicle and Mobile Equipment Non-Assembly Line Coating Operations, Appendix A.

BAAQMD (BAY AREA AIR QUALITY MANAGEMENT DISTRICT) RULE 8-45: This product conforms to the VOC limits listed under Rule 8-45—Motor Vehicle and Mobile Equipment Coating Operations.

INTERNATIONAL REGULATIONS:

Europe: All ingredients conform to the EU requirements.
Regulation (EC) nr. 1907/2006
EEC-directive 2006/121/2006
No label required

16. OTHER INFORMATION

Label Requirements: WARNING! COMBUSTIBLE!

Hazardous Material Information System (HMIS):	Health	1
	Flammability	1
	Reactivity	0
	Personal Protection	



MATERIAL SAFETY DATA SHEET

Noxudol 300 S

Last Updated April 18, 2011

National Fire Protection Association (NFPA):	
---	--

NFPA Ratings: Health: 1, Flammability: 1, Reactivity: 0

NFPA/HMIS Definitions: 0-Least, 1-Slight, 2-Moderate, 3-High, 4-Extreme

Protective Equipment: Goggles & shield; lab coat & apron; vent hood; proper gloves; Class B extinguisher.

Prepared By: Donato Polignone (MSDS Authoring Services)

Part Number: --

Approved By: Soken Trade Corporation

Approval Date: April 18, 2011

Supersedes Date: March 1, 2011

ADDITIONAL INFORMATION:

The data in this Material Safety Data Sheet relates only to the specific material designated herein. It does not relate to use in combination with any other material or in any process. This Material Safety Data Sheet (MSDS) has been reviewed to fully comply with the guidance contained in the ANSI MSDS standard (ANSI Z400.1-2004)

This information is furnished without warranty, expressed or implied, except that it is accurate to the best knowledge of Soken Trade Corporation. The data on this sheet are related only to the specific material designated herein. Soken Trade Corporation assumes no legal responsibility for use or reliance upon these data.

To the best of our knowledge, the information contained herein is accurate. However, neither the above named supplier nor any of its subsidiaries assumes any liability whatsoever for the accuracy or completeness of the information contained herein. Final determination of suitability of any material is the sole responsibility of the user. All materials may present unknown hazards and should be used with caution. Although certain hazards are described herein, we cannot guarantee that these are the only hazards that exist.

END OF MSDS

MATERIAL SAFETY DATA SHEET

PARKER INDUSTRIES

16-8, NIHONBASHI 2-CHOME,
CHUO-KU, TOKYO 103-0027, JAPAN
TELEPHONE: (03) 5205-1973
FAX: (03) 5205-1981

EMERGENCY CONTACT:
CHEMTREC (800) 424-9300

HMIS HAZARD RATING

HEALTH	1
FIRE	1
REACTIVITY	0
PERSONAL PROTECTION	B

Date of Review:	Revised: March 17, 2011
Date of Preparation: November 14, 2007	By: Y. Yamada

SECTION 1: PRODUCT IDENTIFICATION

Product Name: **712AM**
Chemical Family: Petroleum oil/additive blend
Material Usage: Corrosion Preventive Compound

EMERGENCY OVERVIEW: Petroleum oil-based product. When product burns it releases typical hydrocarbon products of combustion. Refer to Section 3 for health effects and to Section 5 for fire hazard data.

SECTION 2: HAZARDOUS INGREDIENTS

Component	Wt%	Recommended Exposure Limits (TWA)
Microcrystalline wax CAS #64742-42-3	5-10	ACGIH TLV: 2 mg/m ³ OSHA PEL: 2 mg/m ³
Petroleum distillates, solvent dewaxed heavy paraffinic CAS #64742-65-0	5-15	ACGIH TLV: 5 mg/m ³ OSHA PEL: 5 mg/m ³
Sulfonic acids, petroleum, Calcium salts, overbased CAS #68783-96-0	5-15	ACGIH TLV: 5 mg/m ³ (oil mist) OSHA PEL: 5 mg/m ³ (oil mist)
White mineral oil, petroleum CAS #8042-47-5	50-60	ACGIH TLV: 5 mg/m ³ (oil mist) OSHA PEL: 5 mg/m ³ (oil mist)
Bentonite, quaternary ammonium compound modified CAS# 68953-58-2	0.3-1.0	Not established

712AM MSDS

Soybean oil polymer with isophthalic acid and pentaerythritol CAS# 66071-86-1	0.4-4	Not established
Castor oil, dehydrated, polymerized CAS# 68038-02-8	5-15	Not established
Calcium Carbonate CAS #471-34-1	5-10	OSHA PEL: 5 mg/m ³ (respirable fraction) OSHA PEL: 15 mg/m ³ (total dust) ACGIH TLV: 10 mg/m ³ ^[2] nuisance dust)

^[2] This component poses a hazard only if a dust is formed, i.e., by sawing, sanding, drilling, etc.

SECTION 3: HEALTH HAZARD INFORMATION

Primary Routes of Entry: Skin absorption, eyes (splashing).

Acute Effects: May cause eye irritation and reversible skin irritation. Prolonged skin exposure may cause dermatitis or oil acne. Breathing mists may cause dizziness or pulmonary irritation.

Chronic Overexposure:

Carcinogenicity: None of the components of this product are listed as carcinogens by NTP, IARC, or OSHA 1910(Z).

Pre-Existing Medical Conditions Aggravated by Exposure: Exposure may aggravate pre-existing respiratory or skin problems.

SECTION 4: FIRST AID PROCEDURES

Inhalation (mist): Move victim to fresh air and call emergency medical care. If not breathing, give artificial respiration; if breathing is difficult, give oxygen.

Eyes: In case of contact with material, immediately flush eyes with running water for at least 15 minutes. Seek immediate medical attention.

Skin: Wash skin with soap and water. Remove and isolate contaminated clothing and shoes at the site.

Ingestion: DO NOT INDUCE VOMITING. Consult a physician. If vomiting occurs spontaneously, keep head below hips to prevent aspiration of liquid into the lungs.

SECTION 5: FIRE AND EXPLOSION HAZARD DATA

Flash Point: >200°C (TCC)

Explosive Limits: LEL: N/A UEL: N/A

EXTINGUISHING MEDIA: Small Fires: Dry chemical, CO₂, water spray, or regular foam. Large Fires: Water spray, fog, or regular foam. Move container from fire area if you can do it without risk. Apply cooling water to sides of containers that are exposed to flames until well after fire is out. Stay away from ends of tanks. For massive fire in cargo area, use unmanned hose holder or monitor nozzles. If this is impossible, withdraw from area and let fire burn. Withdraw immediately in case of rising sound from venting safety device or any discoloration of tank due to fire.

Special Firefighting Protection/Emergency Action: Fire may produce irritating or poisonous gases. Positive pressure self-contained breathing apparatus (SCBA) and structural firefighters' protective clothing will provide limited protection. Keep unnecessary people away; isolate hazard area and deny entry. Stay upwind; keep out of low areas. Isolate for 1/2 mile in all directions if tank, rail car or tank truck is involved in fire. If runoff from fire control occurs, notify the appropriate authorities.

Unusual Fire/Explosion Hazards: Combustible material; may be ignited by flames. Container may explode in heat of fire.

Products of Combustion: Carbon monoxide, carbon dioxide, oxides of sulfur, miscellaneous hydrocarbons.

712AM MSDS

SECTION 6: SPECIAL PRECAUTIONS AND SPILL/LEAK PROCEDURES

Steps to be taken in case Material is Released or Spilled: Shut off ignition sources; no flares, smoking or flames in hazard area. Stop leak if you can do it without risk.

Small Spills: Take up with sand or other noncombustible absorbent material and place into containers for later disposal.

Large Spills: Dike far ahead of liquid spill for later disposal.

SECTION 7: SAFE HANDLING INFORMATION

Precautions To Be Taken In Handling/Storage: Store in cool, well-ventilated area. Keep away from flames. Never use a torch to cut or weld on or near container.

Other Precautions: Never wear contaminated clothing. Launder or dry clean before wearing. Discard oil-soaked shoes. Wash thoroughly with soap and water (waterless hand cleaner may be helpful in removing residues) after use and before smoking or eating. Avoid excessive skin contact.

SECTION 8: EXPOSURE CONTROLS

Respiratory Protection: NIOSH-approved respirator for organic vapor and mist to control exposure where ventilation is inadequate.

Ventilation: General and local exhaust.

Personal Protective Equipment: Protective Gloves: Impervious gloves (Viton, PVOH, etc.) Eye Protection: Safety glasses with sideshields or chemical goggles. Other Protective Clothing or Equipment: If splashing is anticipated, wear rubber apron and boots or other protective equipment to minimize contact.

SECTION 9: REACTIVITY HAZARD DATA

Stability: Stable

Incompatibility: Strong acids, oxidizing agents.

Hazardous Decomposition Products: Carbon monoxide, carbon dioxide, oxides of sulfur, miscellaneous hydrocarbons.

Hazardous Polymerization: Will not occur.

SECTION 10: PHYSICAL AND CHEMICAL PROPERTIES

Color:	Tan
Appearance:	Viscous Liquid
Odor:	Oil
Boiling Point (initial):	NA
Evaporation Rate (n-Butyl Acetate=1):	<<1
Vapor Pressure (mmHg @ 20°C):	3.4
Vapor Density (air=1):	NA
Solubility in Water:	Not Determined
Specific Gravity:	.9-1.0
pH:	Not Applicable
Percent Volatile by Volume:	0

SECTION 11: DISPOSAL CONSIDERATIONS

Waste Disposal Methods: Dispose of in accordance with state, local and federal regulations. Materials may become a hazardous waste through use. If permitted, incineration may be practiced. Consider recycling solvent.

712AM MSDS

SECTION 12: REGULATORY INFORMATION

Volatile Organic Content: (EPA Method 24)

VOC per gallon:

0.165 lbs/gal

EPA Hazardous Waste Number(s) (40CFR Part 261):

D001

EPA Hazard Category (40CFR Part 370):

DELAYED (CHRONIC)

SARA TITLE III

This product contains the following TOXIC CHEMICALS subject to the *Reporting Requirements of Sec. 313 of Title III of the Superfund Amendments and Reauthorization Act of 1986, and of 40CFR Part 372:*

CHEMICAL	CAS NO.	WT %
----------	---------	------

NONE

This product contains the following EXTREMELY HAZARDOUS SUBSTANCE(S) subject to the *Emergency Planning Requirements under Sec. 301-303 (40CFR Parts 300 and 355) and Emergency Release Notification Requirements under Sec. 304:*

CHEMICAL	CAS NO.	WT %	RQ/TPQ Lbs
----------	---------	------	------------

NONE

(CERCLA LIST) This product contains the following HAZARDOUS SUBSTANCE(S) subject to *Emergency Release Notification Requirements under Sec. 304 (40 CFR Part 302):*

CHEMICAL	CAS NO.	WT %	Final RQ Lbs
----------	---------	------	--------------

NONE

CALIFORNIA PROPOSITION 65

This product may contain trace quantities of the following chemicals that are identified by the State of California under the Safe Drinking Water and Toxic Reinforcement Act of 1986 ("Proposition 65") as either a carcinogenic or reproductive hazard:

CHEMICAL	CAS NO.	Estimated Concentration %
----------	---------	---------------------------

NONE

Although the information contained herein is believed to be reliable, it is furnished without warranty of any kind. This information is not intended to be all-inclusive as to the manner and conditions of use, handling, and storage.