

# Headlamp Durability Enhancement

**Service Category** Vehicle Exterior

**Section** Lighting (ext)

**Market** USA



## Applicability

YEAR(S)	MODEL(S)	ADDITIONAL INFORMATION
2010 - 2012	HS250H	

## Introduction

Some 2010 – 2012 model year HS 250h vehicles may exhibit a condition where a halogen low beam headlamp bulb lifetime is shorter than customer expectation. A modified wiring harness is available to address this condition.

## Warranty Information

OP CODE	DESCRIPTION	TIME	OFF	T1	T2
EL1709	Install No. 4 Wire Harness With Headlamp Alignment (One Side)	1.7	90981-13075	72	71
EL1709A	Other Side	1.2			

### APPLICABLE WARRANTY

- This repair is covered under the Lexus Basic Warranty. This warranty is in effect for 48 months or 50,000 miles, whichever occurs first, from the vehicle's in-service date.
- Warranty application is limited to occurrence of the specified condition described in this bulletin.

## Headlamp Durability Enhancement

### Parts Information

PART NUMBER	PART NAME	QTY
04007-52147	Repair Kit, Headlamp Bulb	1

### Headlamp Bulb Repair Kit Parts

PART NUMBER	PART NAME	QTY
90981-13075	Bulb	2
82114-47010	Engine Wire No. 4	2
82999-52010	Sleeve Tube	2
82999-30010	Heat Shrink Tube	2

### Required Tools & Equipment

SPECIAL SERVICE TOOLS (SST)	PART NUMBER	QTY
Plastic Pry Tool Kit*	<a href="#">00002-06020-02</a>	1
Terminal Removing Tool "F"	<a href="#">09991-00510</a>	1
Wire Crimper	<a href="#">09042-2C100</a>	1

\* Essential SST.

**NOTE**

Additional SSTs may be ordered by calling 1-800-933-8335.

REQUIRED TOOLS & MATERIAL	QUANTITY
Nylon Ties	10
Measuring Tool (Metric Ruler)	1
Heat Gun	1

## Headlamp Durability Enhancement

---

### Repair Procedure

1. Replace the headlamp bulbs.
2. AFTER confirming the headlamps work, verify headlight aim is visually correct and that there are no signs of damage or alterations to wiring or the headlamps.

**NOTE**

If a NEW bulb has been installed and the bulb is still inoperative, this bulletin does NOT apply. Continue diagnosis using the applicable Repair Manual.

3. Remove the front bumper cover assembly.  
Refer to the Technical Information System (TIS), applicable model and model year Repair Manual:
  - [2010](#) / [2011](#) / [2012](#) HS 250h:  
*Vehicle Exterior – Exterior Panels/Trim – “Exterior Panels/Trim: Front Bumper: Removal”*

**NOTE**

If the vehicle is equipped with headlight cleaners, be sure to drain the washer fluid system BEFORE the bumper cover is completely removed.

4. Remove the affected headlamp assembly.  
Refer to TIS, applicable model and model year Repair Manual:
  - [2010](#) / [2011](#) / [2012](#) HS 250h:  
*Vehicle Exterior – Lighting (Ext) – “Lighting (Ext): Headlight Assembly (except LED Headlight): Removal”*

# Headlamp Durability Enhancement

## Repair Procedure (Continued)

Figure 1.

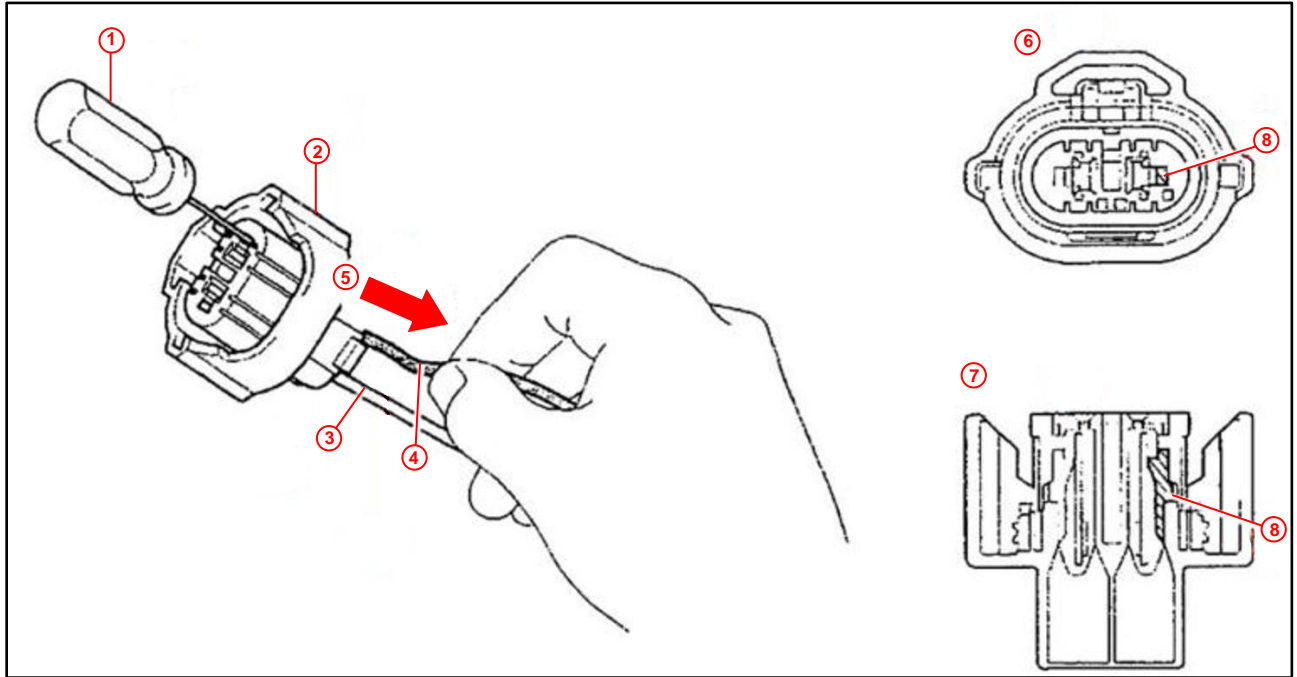

1	Terminal Removing Tool "F"
2	Headlamp Bulb No. 2 Connector
3	Engine ROOM Main Wire Harness (White-Black)
4	Engine ROOM Main Wire Harness (Violet)

5	Remove Violet Wire Harness from Connector
6	Front View
7	Cross Section
8	Lock

5. Modify the existing headlamp harness and install the engine wire No. 4 harness.

**NOTE**

This wiring harness extends the factory headlamp wiring harness and will be placed between the headlight socket and existing headlamp wiring harness. The harness will be cut with a special crimping tool to make an adequate crimp. It is important to use the suggested crimp tool and follow the instructions below to ensure a proper crimp.

- A. Remove the green cap from the headlamp connector by carefully using a small screwdriver or pick to detach the cap as shown.

Figure 2.

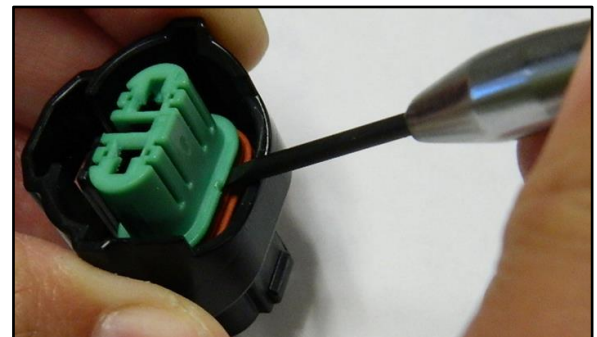

# Headlamp Durability Enhancement

## Repair Procedure (Continued)

- B. AFTER the cap is removed, remove terminal 2 (violet wire) from the low beam headlight connector wire using terminal removing tool "F."

SST: P/N 09991-00510

- (1) AFTER the terminal cap is removed, gently insert the terminal removing tool "F" into the connector between the terminal and the terminal lock (see Figures 1 and 3), then gently push the terminal lock to the outward side of the connector. Do NOT overstress the lock or it will NOT properly hold the terminal when reassembled.

**NOTICE**

When inserting terminal removing tool "F," pry carefully outward just enough to remove the terminal from the wire side. Excessive pressure may damage the lock or bend the tool.

- (2) As the lock is held outward, gently pull on the violet wire from the back of the connector to remove it.

- C. Insert the terminal of engine wire No. 4 (white-black) in the headlamp bulb No. 2 connector.
- D. Cut the violet wire previously removed from the headlamp bulb No. 2 connector near the terminal.

Figure 3.

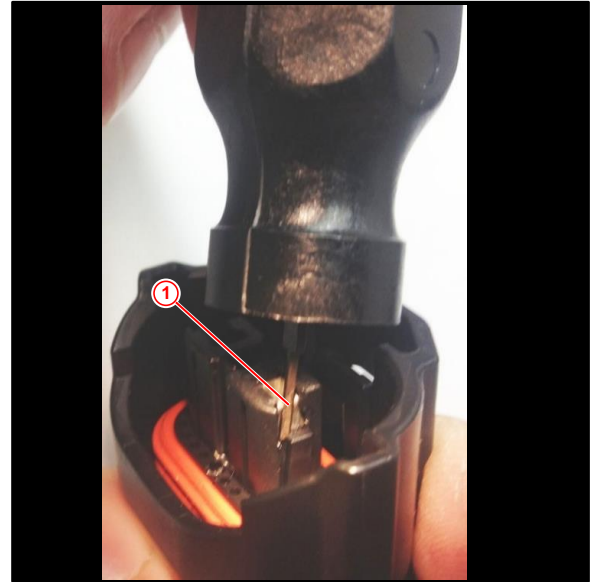

1	TerminalLock
---	--------------

Figure 4.

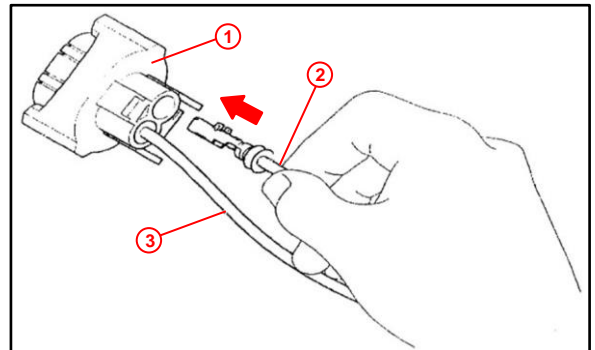

1	Headlamp Bulb No. 2 Connector (Low Beam)
2	Insert Engine Wire No. 4 in Terminal (White-Black)
3	Engine ROOM Main Wire Harness (White-Black)

# Headlamp Durability Enhancement

## Repair Procedure (Continued)

- E. Remove the wire outer coat insulation 10 mm from the edge.

**NOTE**

Measure the length of the wire carefully to ensure the wire fits properly.

Figure 5.

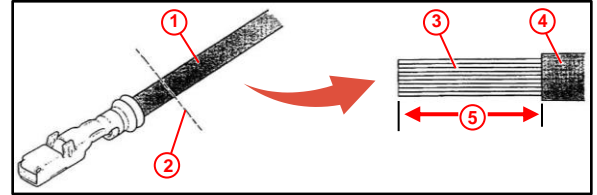

1	Engine ROOM Main Wire Harness (Violet)
2	Cut Here
3	Strip Off 10 mm of Insulation
4	Wire Insulation Coat
5	10 mm

- F. Remove 10 mm of the wire outer coat insulation from engine wire No. 4 (white-black wire).

Figure 6.

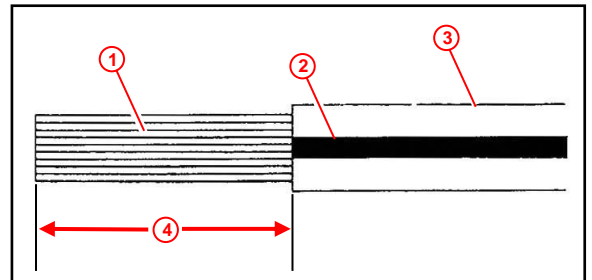

1	Strip Off 10 mm of Insulation
2	Wire Insulation Coat
3	Engine ROOM Wire No. 4
4	10 mm

- G. Insert a section of heat shrink tubing (P/N 82999-30010) over the engine wire No. 4.
- H. Insert the stripped bare wires into the sleeve tube (P/N 82999-52010), ensuring the wires overlap in the center of the crimp.

# Headlamp Durability Enhancement

## Repair Procedure (Continued)

- I. Using the wire crimper, apply a 2 crimp to the center of the sleeve tube.

SST: P/N 09042-2C100

**NOTE**

The wire crimper tool handles **MUST** be fully depressed for them to release, so verify alignment is proper prior to applying pressure to crimper handles.

Figure 7.

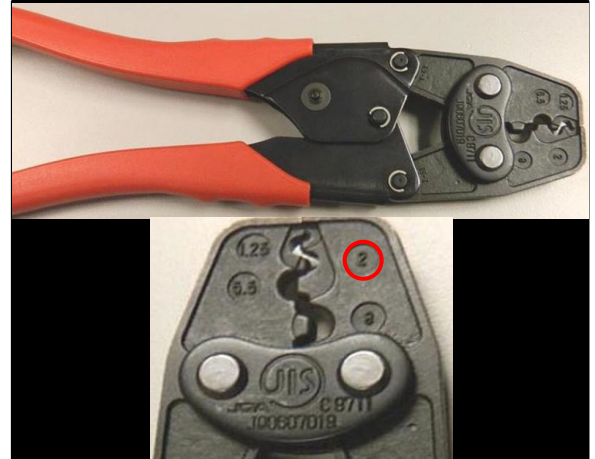

- J. Apply one additional crimp on both sides of the center crimp, as shown.

Figure 8.

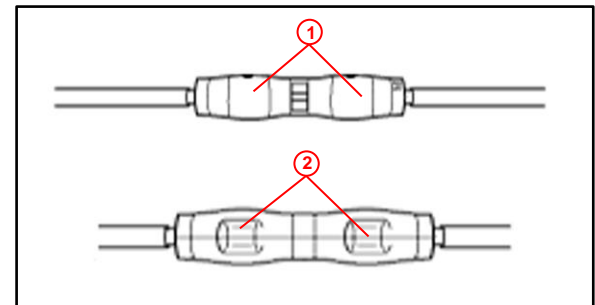

<b>1</b>	Apply a 2 Crimp Here
<b>2</b>	Crimped Sleeve Tube

- K. Slide the heat shrink tubing over the crimp and apply sufficient heat with a heat gun to close the heat shrink around the wire insulation.

Figure 9.

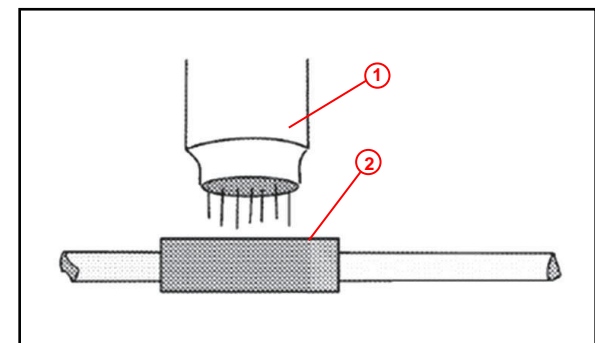

<b>1</b>	Heat Gun
<b>2</b>	Shrink Tube

## Headlamp Durability Enhancement

### Repair Procedure (Continued)

- L. Insert the headlamp connector back into the headlamp socket.
- M. Test for normal high and low beam headlamp operation with headlamp temporarily connected to the wiring harness.
- 6. Reinstall the headlamp assembly.  
Refer to TIS, applicable model and model year Repair Manual:
  - [2010](#) / [2011](#) / [2012](#) HS 250h:  
*Vehicle Exterior – Lighting (Ext) – “Lighting (Ext): Headlight Assembly (except LED Headlight): Installation”*
- 7. Install the engine wire No. 4 wire harness on the left or right side. Be sure to attach nylon ties less than 100 mm apart.

**NOTE**

- Each nylon tie should be located no more than 100 mm from the next one.
- There should be no free play between the factory harness and the engine wire No. 4 wire harness loom.
- The ties should face outside the vehicle.
- Be sure to trim the ties AFTER application.

A. Driver Side Installation:

- (1) Install the connector from the engine wire No. 4 harness connector into the headlamp assembly.
- (2) Route the No. 4 harness by following the contour of the current harness. (Test fit routing as necessary to ensure fit.)
- (3) Apply nylon ties less than 100 mm from each other, facing outward.

**NOTE**

Five tie wraps are needed for the driver side.

- (4) Trim the nylon ties AFTER installation.

**Figure 10. Nylon Ties Less Than 100 mm Apart**

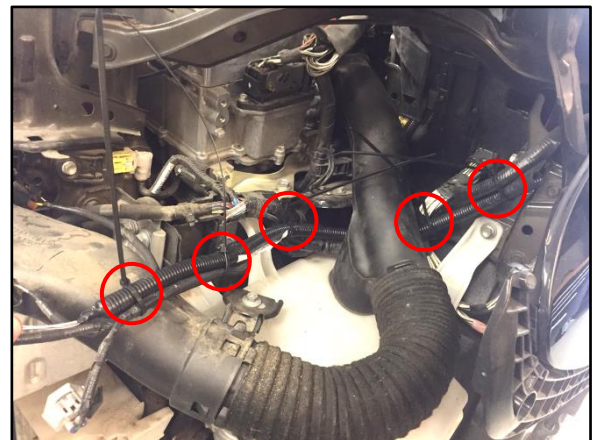

## Headlamp Durability Enhancement

### Repair Procedure (Continued)

#### A. Passenger Side Installation:

- (1) Plug the engine wire No. 4 harness connector into the headlamp assembly.
- (2) Route the No. 4 harness by following the contour of the current harness. (Test fit routing as necessary to ensure fit.)
- (3) Apply the nylon ties less than 100 mm from each other, facing outward.

**NOTE**

Five tie wraps are needed for the passenger side.

- (4) Trim the nylon ties AFTER installation.

#### 8. Reinstall the bumper cover.

Refer to TIS, applicable model and model year Repair Manual:

- [2010](#) / [2011](#) / [2012](#) HS 250h:

*Vehicle Exterior – Exterior Panels/Trim – “Exterior Panels/Trim: Front Bumper: Installation”*

#### 9. Adjust the headlamps.

Refer to TIS, applicable model and model year Repair Manual:

- [2010](#) / [2011](#) / [2012](#) HS 250h:

*Vehicle Exterior – Lighting (Ext) – “Lighting (Ext): Headlight Assembly (except LED Headlight: Adjustment”*

#### 10. Verify normal operation of ALL affected systems.

**Figure 11. Nylon Ties Less Than 100 mm Apart**

