



Preliminary Information

PIC5955A 4ET50 Electric Drive Unit Service Rotor B Replacement

Models

Brand:	Model:	Model Years:	VIN:		Engine:	Transmissions:
			from	to		
Chevrolet	Volt	2011 - 2015	All	All	LUU	MKA
Cadillac	ELR	2014 - 2016	All	All	LUU	MKA

Supersession Statement

This PI was superseded to update Model Years. Please discard PIC5955.

The following diagnosis might be helpful if the vehicle exhibits the symptom(s) described in this PI.

Condition / Concern

The proper way to address a Rotor B bearing noise is to perform a bearing only replacement per P/I #[PIP5081](#). This can be done on-car. If this is a repeat repair, and TAC recommends a Rotor B replacement, this must be done off car per S/I.

Recommendations / Instructions

When replacing the Rotor B Assembly, it is imperative that the technician follows SI (Document ID: 3641026) exactly step by step. The transmission must be removed from the vehicle. Attempts to try this as an on-car procedure will result in subsequent failures and possible transmission damage. Damage or repeat repairs due to not following publish procedures will not be covered by warranty.

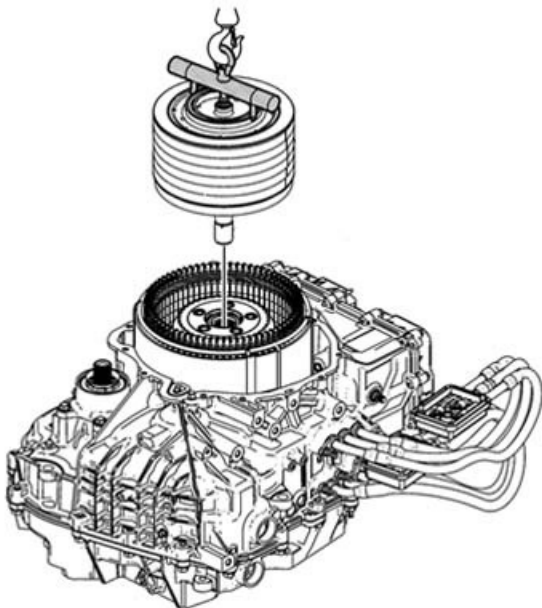

Please follow this diagnostic or repair process thoroughly and complete each step. If the condition exhibited is resolved without completing every step, the remaining steps do not need to be performed.

